

Performance Evaluation of LoRa in Farm Irrigation System with Internet of Things

Kurniawan D. Irianto

Department of Informatics, Universitas Islam Indonesia, Indonesia
k.d.irianto@uii.ac.id

Article Info

Keywords:

Performance Evaluation, LoRa
Communication, Internet of Things, Farm
Irrigation System

Abstract

Long Range (LoRa) Communication is one of the emerging Internet of Things (IoT) technologies and has been widely discussed by researchers. LoRa is also part of the Low Power Wide Area Networks (LPWAN) technology where this technology focuses on communication systems on energy efficiency, wide coverage, low data rates, and long battery life. LoRa uses industrial, scientific, and medical (ISM) radio frequencies. These frequencies can be used for free without paying for a license. Theoretically and under ideal conditions, the LoRa range can reach < 3 km in urban areas and > 3 km in rural areas. However, only a few studies discuss the evaluation and analysis of LoRa performance, which is implemented in the real world with particular case studies. This article aims to evaluate and analyze the performance of LoRa, which is applied to a case study of an IoT-based agricultural irrigation system. Several parameters will be assessed and analyzed, including distance, received signal strength indication (RSSI), spreading factor, coding rate, power transmission, and packet delivery ratio (PDR). Experimental and measurement results show that LoRa can transmit data packets up to a distance of 2.5 km but with a very low PDR rate of around 5-7%. The results also show that LoRa can work optimally if the distance is < 1 km with a PDR rate of about 70-100%.

1. Introduction

Long Range (LoRa) Communication is one type of communication using Low Power Wide Area Network (LPWAN) technology [1]. LPWAN technology aims to optimize communication as far as possible at the expense of data transfer rates [2], [3]. In addition, LPWAN also focuses on energy savings so that the tools used in LPWANs that usually use battery energy sources can last for years. Moreover, LPWANs are generally used in conjunction with a network of sensors. Therefore, the technologies that exist in LPWANs have several unique criteria, namely low power consumption, low data transfer, long battery life, low cost, and long range [4], [5], [6].

The application of LoRa in the IoT field has been widely carried out in various areas, one of which is agriculture [7], [8], [9]. Many modern farms are utilizing IoT technology to simplify and increase agricultural yields [10], [11]. The combination of agriculture and the IoT results in a new approach called *smart farming*. Smart farming makes it possible to increase productivity and reduce farm losses [12], [13]. Among the uses of IoT in smart farming are agricultural machines that can be operated automatically, increasing efficiency in agricultural resource management, monitoring agricultural products using sensors, and automating agricultural irrigation systems [14], [15].

Several studies on irrigation systems with IoT technology have been done. Some use wireless sensor networks as a communication network [16], [17]. There are also studies on irrigation systems that utilize the internet and cloud connections [18], [19], [20]. In addition, several kinds of research on irrigation systems use machine learning and the cloud [21]. Furthermore, several IoT researchers have applied LoRa communication for monitoring IoT-based irrigation systems namely in [22], [23], [24], [25], [26]. One example of the latest research that uses LoRa in agricultural irrigation systems is a study conducted in [15]. The author built an intelligent agricultural irrigation monitoring system prototype using LoRa as its wireless communication model and conducted actual tests and measurements. The results of its study indicate that the LoRa communication applied to the irrigation monitoring system can function well within a communication range of less than 1 km. If the distance is further than that, it is not recommended because the packet error rate (PER) is high, so the system cannot run optimally. However, this is still far from some of the LoRa literature, which claims that LoRa can communicate as far as > 3 km in a rural environment and < 3 km in an urban setting. Therefore, it is necessary to conduct more in-depth research to evaluate and analyze the performance of LoRa in its application in agricultural irrigation systems.

This article aims to evaluate and analyze the performance of LoRa more comprehensively, which is applied to the case of IoT-based agricultural irrigation systems. Our contribution to this study is we design several scenarios to evaluate and analyze LoRa performance and implement it in the farm irrigation system. Several parameters that are used in the evaluation are 1) distance, 2) received signal strength indicator (RSSI), 3) spreading factor (SP), coding rate (CR), transmission power, and packet delivery ratio (PDR). The result shows that the system can only work optimally within a distance of less than one kilometer. Furthermore, the system can send data up to 2.5 kilometers. However, the PDR is getting worse, with a 5–7% PDR.

2. Research Method

2.1. System Design

The design of the system in this study can be seen in Figure 1. Four rice fields are regulated in this irrigation system, and each area of rice fields has a water gate. Each of these gates will be controlled by a microcontroller to handle the incoming and outgoing water flow. In addition, the microcontroller will also measure the water level in the fields using a water level sensor. If the amount of water required in the areas is not much, then the microcontroller will open the water gates. However, if the volume of water is too high, the gates that allow water to get in will be closed, and the gates that allow water to get out will be opened. For example, rice fields A and B are connected and have water gates. Gate A is used as an inlet sluice gate, and Gate B sluice gate is an exit sluice. It applies as well to rice fields C and D.

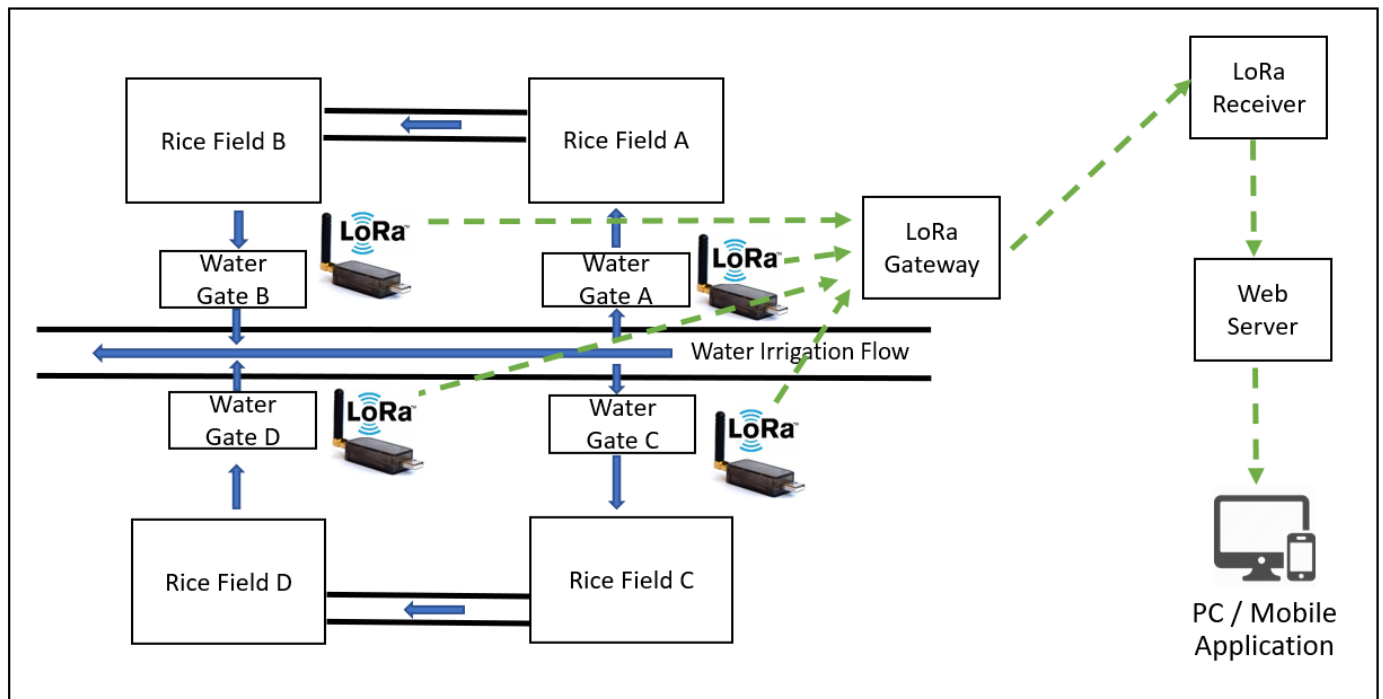

Figure 1. Design of smart farm irrigation system

The data in each rice field will be sent to the gateway using LoRa wireless communication before forwarded to the LoRa receiver. The system uses ESP32 as the microcontroller to control the LoRa Gateway and Receiver. In addition, ESP32 is able to act as a web server. Therefore, the data in LoRa Receiver will be sent to the web server. Finally, the monitoring system can be done through a web-based application via a smartphone or PC by accessing the data stored in the web server. In this case, all data communication is entirely by LoRa without internet access.

The flowchart of the system can be seen in Figure 2. After the system is started, all the gates (i.e. A, B, C, and D) are closed. Water gates A and C are used to allow water into all fields. Meanwhile, gates B and D remove water from the land if the water volume is excessive. Gates A and C will enter the water if the condition of the water volume is less than 50% and will stop water from entering if the volume is more than 80%. Meanwhile, water gates B and C will be opened if the water volume is more than 90%. Under normal conditions, the system will maintain the state of the water volume between 50% and 80%. However, if there is heavy rain, the amount of water in the fields will increase because of the rain. Then this excess water must be removed by opening sluice gates B and C. After that, LoRa A-D will send all information on the volume of water in all fields to the LoRa gateway. The LoRa gateway then forwards the information to the LoRa receiver, and the data is displayed on the PC/mobile apps for monitoring.

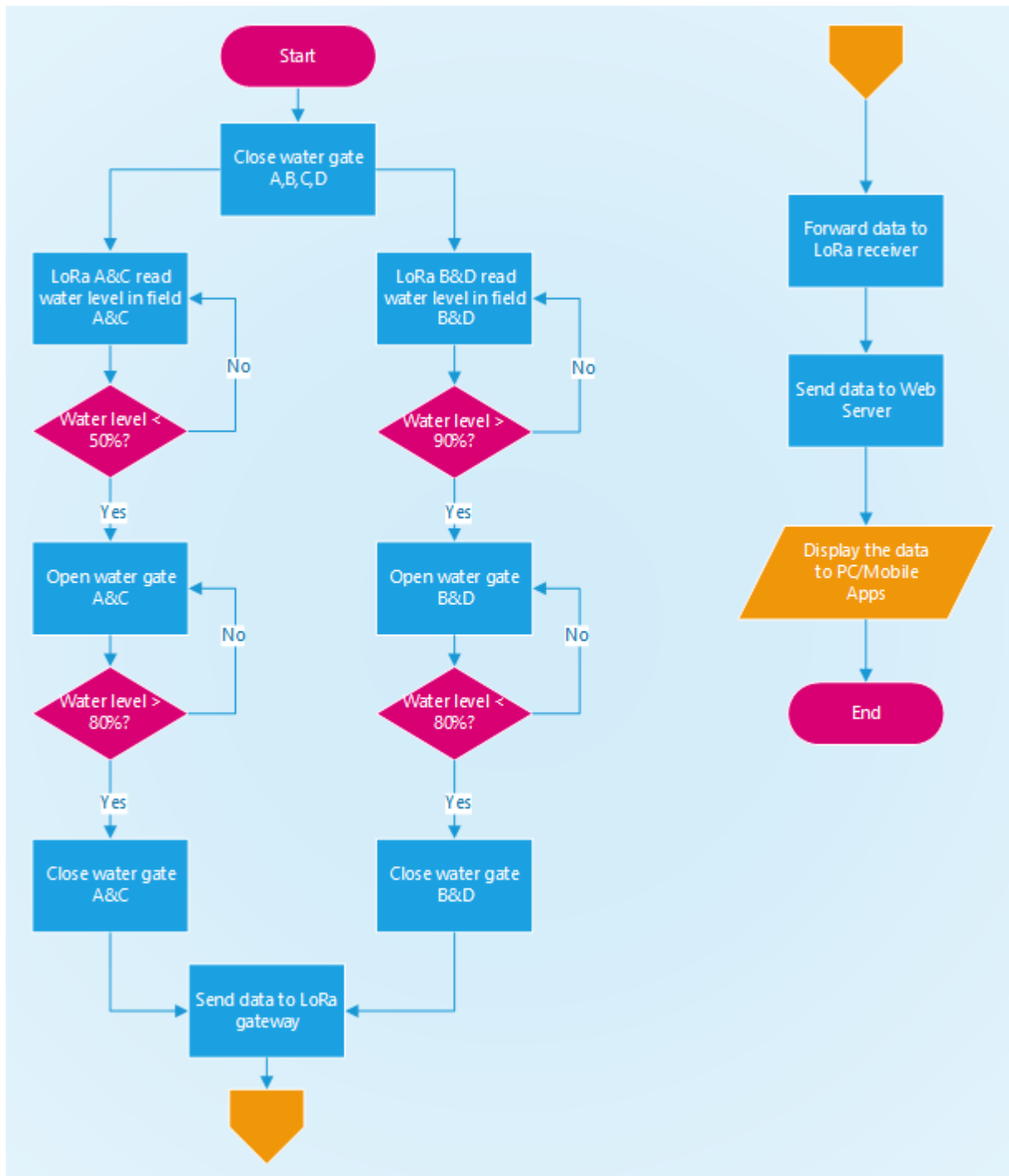

Figure 2. Flowchart of smart farm irrigation system

2.3. LoRa Parameters and Prototyping

One of the fundamental reasons LoRa has an advantage over other wireless communication models in the field of IoT is the communication range factor. Theoretically and under ideal conditions, the LoRa range could reach about 1-3 km in urban environments and > 3 km in rural areas. In this study, LoRa coverage will be used as one of the parameters in the evaluation and analysis. The other parameters are the received signal strength indicator (RSSI), spreading factor (SF), coding rate (CR), power transmission, and packet delivery ratio (PDR).

All hardware used to build IoT and LoRa-based agricultural irrigation systems is determined at this stage. In this study, the built system was in the form of a prototype. The hardware used to build this prototype in outline is as follows:

1. Water level sensor to measure water demand.
2. ESP32 as the main control device or microcontroller.
3. LoRa RMF95W module, which works at a frequency of 915 Mhz.
4. LoRa 3dbi antenna.
5. Relay.
6. Solenoid Valve.

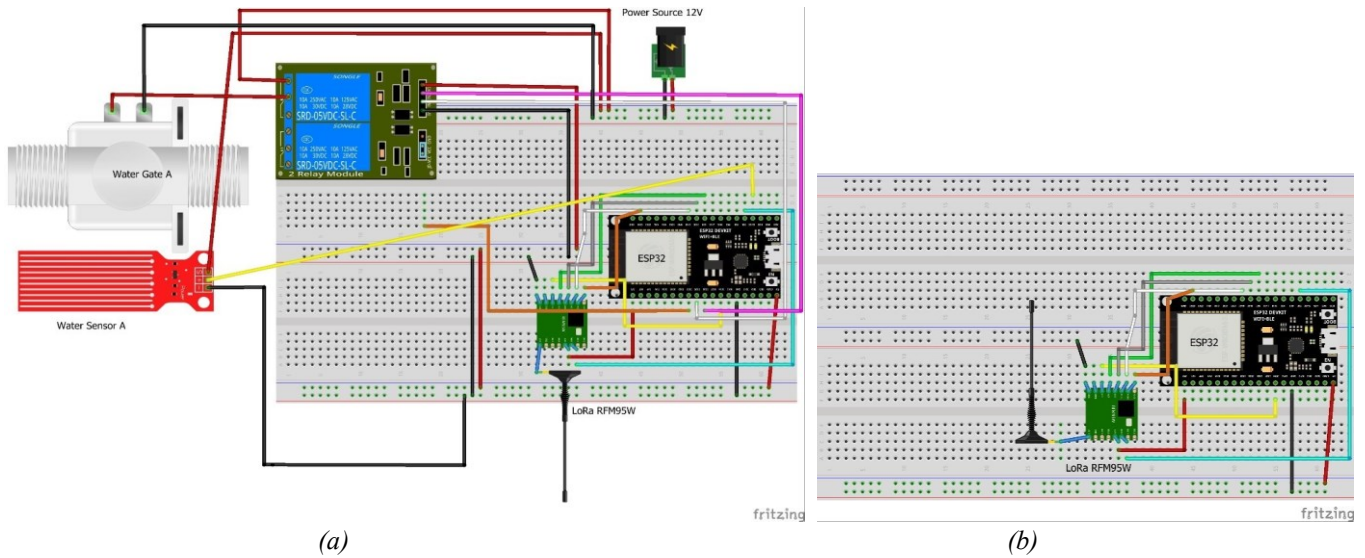

Figure 3: a. Schematic for LoRa A; b. Schematic for LoRa gateway and receiver

After the selection of tools is complete, the following process is assembled. The prototype assembly stage is the stage for building an intelligent irrigation system using the tools that have been determined in the previous stage, namely the tool selection stage. At this stage, software development is carried out to run an intelligent irrigation system. The programming language used is C++ and the Arduino IDE editor. Then, a Web-based interface was also developed.

The circuit schematic for the LoRa A system can be shown in Figure 3a. The circuit schematic is also applied to the LoRa B, C, and D systems because they have the same circuit. The circuit schematic for the LoRa gateway and receiver can be seen in Figure 3b.

2.4. Experimental Set Up

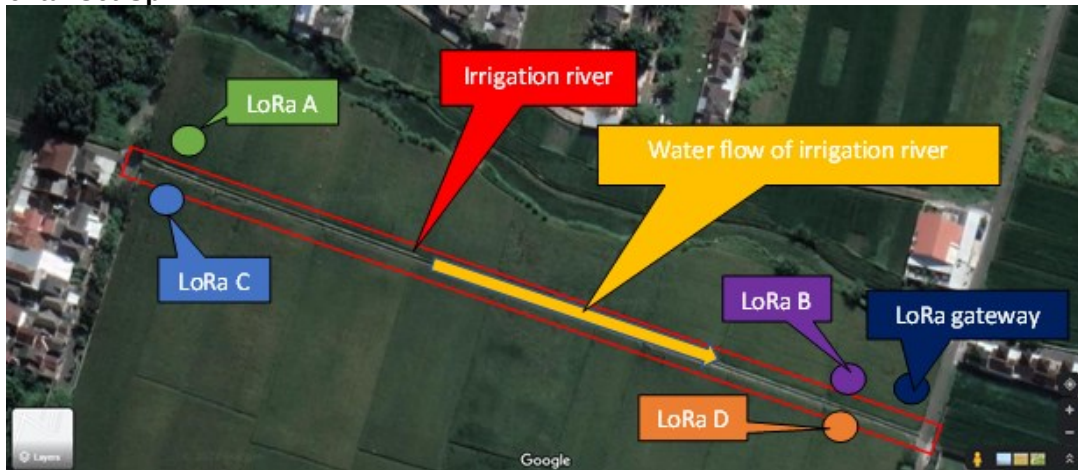

Figure 4. Location and experimental settings

The experiment was carried out in the rice fields in Singopuran, Kartasura, Sukoharjo, Central Java, Indonesia. The exact location can be seen on Google Maps coordinates -7.549747, 110.747984. Reason for choosing this location is that there are still quite a lot of rice fields even though there are also residential areas, and it is also close to the research location. The location and experimental settings can be seen in Figure 4. It shows several system parts, such as an irrigation river in the middle, LoRa A, B, C, D, and gateway positions. The flow of irrigation water flows from left to right. The water is used to irrigate rice fields. The distance between LoRa A and B is about 300 m. All data from LoRa A, B, C, and D will be sent to the LoRa gateway.

The experiment was carried out by providing the packet ID according to the LoRa PHY settings. Table 1 shows several scenarios based on the package ID that consists of 3 components namely coding rate (CR), bandwidth (BW), and spreading factor (SF). SF can be set to values ranging from 6 to 12. In this setting, SF is set to 7 (default), 9, and 11. CR is set to the minimum and maximum values of 5 and 8. BW is set to 125kHz, except for settings on package IDs 250-5-7 and 250-8-7. Only the SF7 can be set to a maximum BW setting of 250kHz, so the SF7 has two options, namely 125kHz and 250kHz. TX power is given a fixed value and does not change, namely 13. The height of the antenna is between 1 meter and 2.5 meters above the ground.

Table 1. Various LoRa PHY Settings

Packet ID	TX Power (dBm)	BW (kHz)	CR	SF
125-5-7	13	125	5	7
125-8-7	13	125	8	7
125-5-9	13	125	5	9
125-8-9	13	125	8	9
125-5-11	13	125	5	11
125-8-11	13	125	8	11
250-5-7	13	250	5	7
250-8-7	13	250	8	7

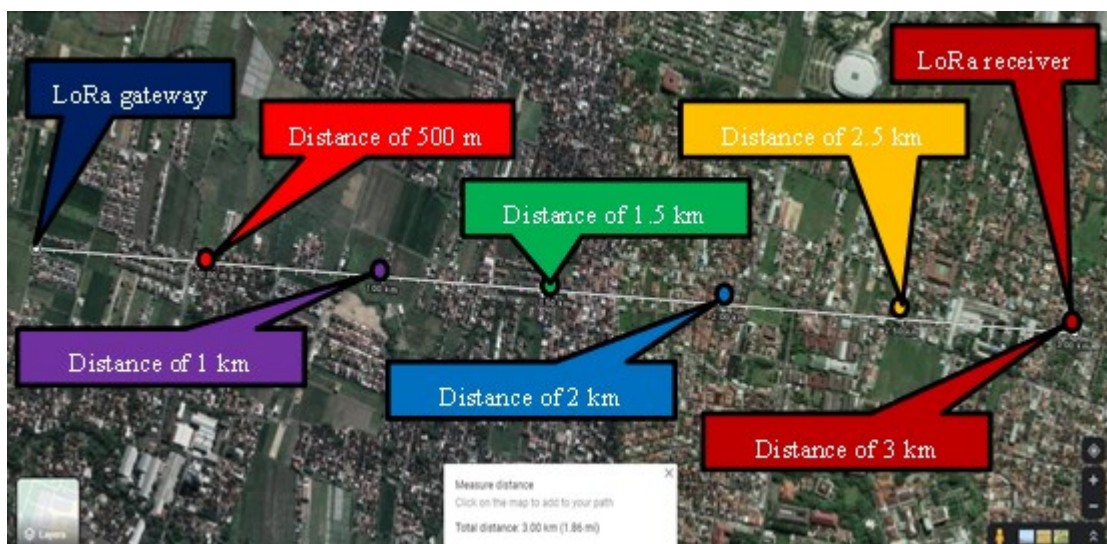

Figure 5. Distance measurement of LoRa gateway and receiver

In each LoRa PHY setup scenario, 100 packets of data are sent. The data structure is a character type and is 5 bytes in size. Bytes 1-3 are used to distinguish the experimental settings used. The 4th byte is the water level value, and the 5th byte is used for numbering the packets sent. Data packets are sent every 5 seconds. It aims to provide sufficient pause and avoid interference or collisions between one data packet with another data packet. Then, the position and distance of the LoRa receiver vary from 500 m, 1 km, 1.5 km, 2 km, 2.5 km, and 3 km. It can be seen in Figure 5.

2.5. Performance Matrices

This experiment will calculate the system's reliability in sending data packets and the received signal strength indication (RSSI). The RSSI is used to analyze the system for different LoRa PHY settings at different distances. Reliability can be calculated as the ratio of the amount of data received to the amount sent. This ratio is also known as the packet delivery ratio (PDR). The formula for calculating PDR is as follows:

$$PDR = \frac{d}{t} \quad (1)$$

where PDR is the packet delivery ratio, d is the packet that was successfully delivered (delivered), and t is the total packet sent (transmitted).

3. Results and Discussion

3.1. LoRa A,B,C,D and Gateway

The result of packet delivery ratio (PDR) and received signal strength indicator (RSSI) at LoRa gateway can be seen in Table 2. Moreover, the PDR calculation can be seen in equation 1. The packet ID represents a various setting of bandwidth (BW), coding rate (CR), and spreading factor (SF). LoRa A and C have a distance of 300m from the Gateway. Meanwhile, LoRa B and D are located 20m away from the Gateway. In addition, the antenna height is placed around two meter above ground. The result of experiment shows that the distance has an impact to RSSI and PDR values. For instance, LoRa B and D have a higher value of RSSI and PDR. In contrast, the result of PDR and RSSI of LoRa A and C is lower. Therefore, the shorter the distance, the better the result. The result also indicates that the coding rate and bandwidth setting can increase the PDR. For example, a bandwidth of 250Hz has a slightly higher value of PDR than a bandwidth of 125Hz. Packet ID of 250-5-7 has a better PDR by around 2% than packet ID of 125-5-7. In addition, a coding rate of 8 increases the PDR by approximately 1% to 3% compared to a coding rate of 5.

Table 2. Result of LoRa PHY settings for LoRa A-D and gateway

Packet ID (BW-CR-SF)	LoRa A (300 m)		LoRa C (300 m)		LoRa B (20 m)		LoRa D (20 m)	
	PDR (%)	RSSI (dBm)	PDR (%)	RSSI (dBm)	PDR (%)	RSSI (dBm)	PDR (%)	RSSI (dBm)
125-5-7	95,3	-71.74	95,4	-71.64	96,3	-59.04	96,5	-59.64
125-8-7	97,5	-69.22	97,5	-69.32	98,5	-51.50	98,6	-51.30
125-5-9	94,1	-71.98	94,3	-71.78	95,1	-55.50	95,3	-55.80
125-8-9	95,4	-76.27	95,5	-76.57	96,4	-53.80	96,4	-53.50
125-5-11	98,2	-78.74	98,1	-78.84	99,6	-55.37	99,3	-55.87
125-8-11	98,5	-75.74	98,6	-75.44	98,9	-58.67	98,8	-58.77
250-5-7	97,7	-70.20	97,5	-70.10	98,1	-55.10	98,4	-55.30
250-8-7	98,8	-69.99	98,7	-69.79	98,3	-55.70	98,5	-55.90

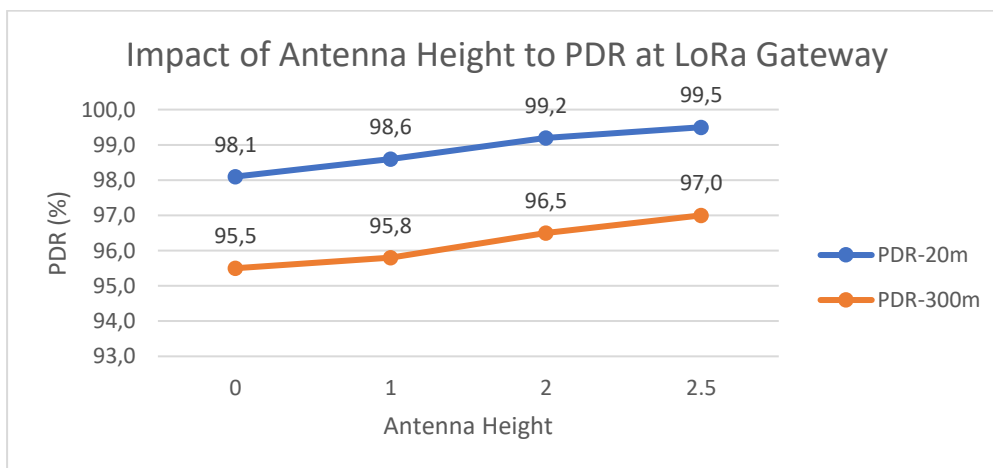

Figure 6. Impact of Antenna Height to PDR at LoRa Gateway

3.2. Impact of Antenna Height

We were also experimenting with the height of the antenna. Figure 6 exhibits the impact of antenna height on the PDR result in LoRa gateway. The antenna is placed above the ground from 0m to 2.5m. It shows the higher the antenna, the better the PDR number. The PDR value with an antenna height of 2.5m is higher by about 2% than the PDR with an antenna height of 0m above the ground. It means that with a height of 2.5m, the antenna can send the signal better and farther. Thus, the receiver will have a better receiving.

3.3. LoRa Gateway and Receiver

The result of PDR and RSSI at the LoRa receiver can be seen in Figure 7. The position of LoRa receiver from LoRa Gateway is evaluated with different distances from 500 meters to 3 kilometers, as shown in Figure 5. The LoRa receiver will receive the transmitted data from the LoRa Gateway. The result shows that LoRa receiver can receive up to 2.5 kilometers of incoming packets. However, it has the worst PDR number. It is around 5% to 7% of PDR. The receiver also cannot get the packets at all in the distance of 3 kilometers.

Meanwhile, the PDR value can be received optimally if the distance is less than 1 kilometer with a value of 70%-90%. Despite that, LoRa Receiver can still get the packet at a distance of 1.5 kilometers with a PDR of around 50%. Furthermore, RSSI with a distance of 500m has the best value, around -71 to -75 dBm. RSSI represents the strength of the received signal. The lower its number, the better it is receiving. Also, when the LoRa Receiver is placed at a 3 kilometers distance, its RSSI is 0 dBm. It means LoRa Receiver cannot receive any signal and data. Thus, for implantation in the real-world case, especially in the irrigation system, it is better if the LoRa nodes are placed at a distance of less than 1 kilometer.

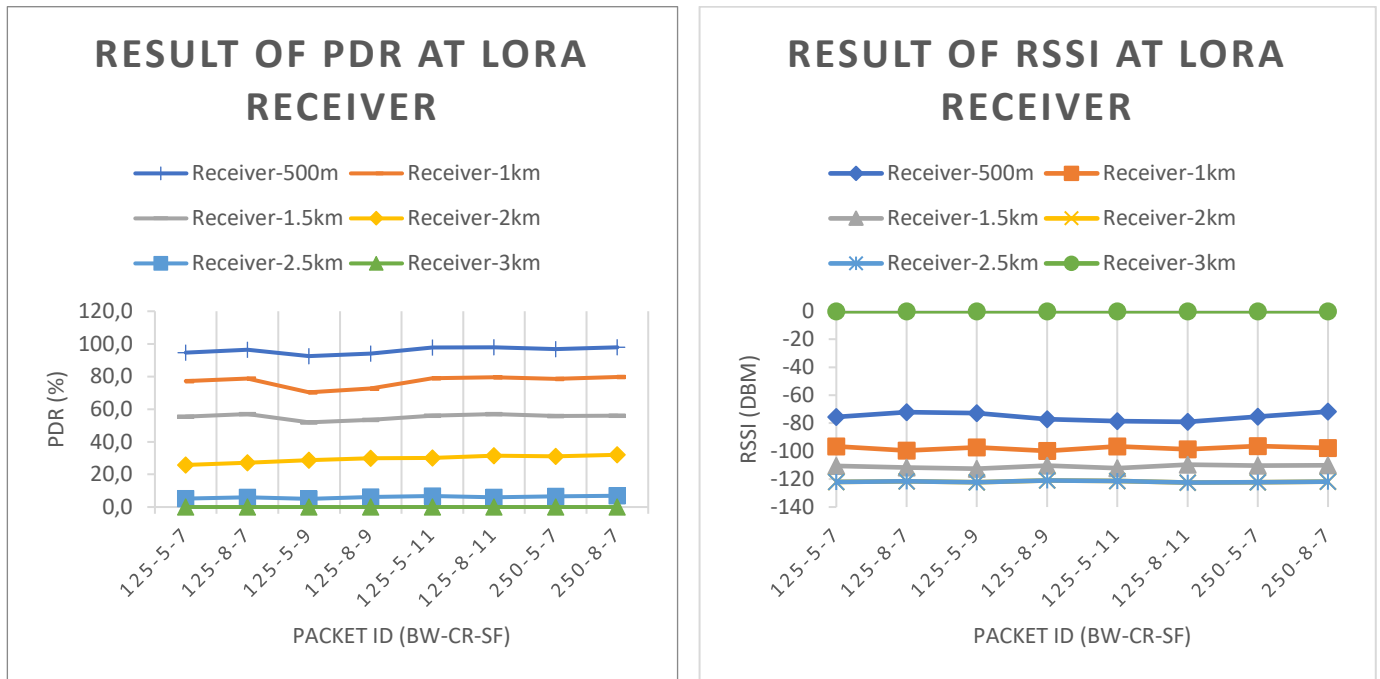

Figure 7: a. Result of PDR at LoRa Receiver; b. Result of RSSI at LoRa Receiver

4. Conclusion

This article discusses the performance evaluation of LoRa, which is implemented in an IoT-based agricultural irrigation system. This system analyzes two parameters: the received signal strength indicator (RSSI) and the packet delivery ratio (PDR). The information data sent by LoRa communication is the value of the water level on agricultural land. The experimental results show that LoRa can be applied to agricultural irrigation systems. LoRa can also send data packets as far as 2.5 km, but with a low PDR value of less than 10%. It makes the system not work properly and is not recommended. The system will work well and optimally if the LoRa distance is less than 1 km. The PDR value obtained is around 70-100%.

One of the challenges in this system is that the PDR level will start to decrease if the LoRa distance is > 1 km. For the future research, a deeper investigation is needed to overcome the low PDR value. A method to reduce the packet error rate in LoRa communication is urgently needed. Therefore, LoRa can be applied to certain cases in the real world of agriculture.

Acknowledgement

The author would like to thank the Department of Informatics, Universitas Islam Indonesia, for funding this research with a collaborative research scheme of lecturers and students in 2022. Thanks also to the students of Department of Informatics, who have assisted in this research.

References

- [1] M. Misbahuddin, M. S. Iqbal, D. F. Budiman, G. W. Wiriasto, and L. A. S. I. Akbar, "EAM-LoRaNet: Energy Aware Multi-hop LoRa Network for Internet of Things," *Kinet. Game Technol. Inf. Syst. Comput. Network, Comput. Electron. Control*, vol. 4, no. 1, pp. 81–90, 2022, doi: 10.22219/kinetik.v7i1.1391.
- [2] L. Li, J. Ren, and Q. Zhu, "On the application of LoRa LPWAN technology in Sailing Monitoring System," *2017 13th Annu. Conf. Wirel. On-Demand Netw. Syst. Serv. WONS 2017 - Proc.*, pp. 77–80, 2017, doi: 10.1109/WONS.2017.7888762.
- [3] Q. Zhou, K. Zheng, L. Hou, J. Xing, and R. Xu, "Design and implementation of open LORA for IoT," *IEEE Access*, vol. 7, pp. 100649–100657, 2019, doi: 10.1109/ACCESS.2019.2930243.
- [4] B. S. Chaudhari, M. Zennaro, and S. Borkar, "LPWAN technologies: Emerging application characteristics, requirements, and design considerations," *Futur. Internet*, vol. 12, no. 3, 2020, doi: 10.3390/fi12030046.
- [5] Y. Song, J. Lin, M. Tang, and S. Dong, "An Internet of Energy Things Based on Wireless LPWAN," *Engineering*, vol. 3, no. 4, pp. 460–466, 2017, doi: 10.1016/J.ENG.2017.04.011.
- [6] K. Mekki, E. Bajic, F. Chaxel, and F. Meyer, "A comparative study of LPWAN technologies for large-scale IoT deployment," *ICT Express*, vol. 5, no. 1, pp. 1–7, 2019, doi: 10.1016/j.ict.2017.12.005.
- [7] Y. Yang, "Design and Application of Intelligent Agriculture Service System with LoRa-based on Wireless Sensor Network," *Proc. - 2020 Int. Conf. Comput. Eng. Appl. ICCEA 2020*, pp. 712–716, 2020, doi: 10.1109/ICCEA50009.2020.00155.
- [8] V. P. Kour and S. Arora, "Recent Developments of the Internet of Things in Agriculture: A Survey," *IEEE Access*, vol. 8, pp. 129924–129957, 2020, doi: 10.1109/ACCESS.2020.3009298.
- [9] T. Anandhakrishnan, S. M. Jaisakthi, and Lohotsaurabh, "Internet of things in agriculture-survey," *J. Comput. Theor. Nanosci.*, vol. 15, no. 6–7, pp. 2405–2409, 2018, doi: 10.1166/jctn.2018.7478.
- [10] A. Kapoor, A., Bhat, S. I., Shidnal, S., & Mehra, "IMPLEMENTATION OF IoT (INTERNET OF THINGS) AND IMAGE PROCESSING IN," *Int. Conf. Comput. Syst. Inf. Syst. Sustain. Solut.*, pp. 21–26, 2016.
- [11] A. Khanna and S. Kaur, "Evolution of Internet of Things (IoT) and its significant impact in the field of Precision Agriculture," *Comput. Electron. Agric.*, vol. 157, no. December 2018, pp. 218–231, 2019, doi: 10.1016/j.compag.2018.12.039.
- [12] A. D. Boursianis *et al.*, "Internet of Things (IoT) and Agricultural Unmanned Aerial Vehicles (UAVs) in smart farming: A comprehensive review," *Internet of Things (Netherlands)*, vol. 18, no. xxxx, p. 100187, 2022, doi: 10.1016/j.iot.2020.100187.
- [13] A. Castañeda-Miranda and V. M. Castaño-Meneses, "Internet of things for smart farming and frost intelligent control in greenhouses," *Comput. Electron. Agric.*, vol. 176, no. June, p. 105614, 2020, doi: 10.1016/j.compag.2020.105614.
- [14] S. Terence and G. Purushothaman, "Systematic review of Internet of Things in smart farming," *Trans. Emerg. Telecommun. Technol.*, vol. 31, no. 6, pp. 1–34, 2020, doi: 10.1002/ett.3958.
- [15] K. D. Irianto, "Design of Smart Farm Irrigation Monitoring System Using IoT and LoRA," *RESTI*, vol. 6, no. 1, pp. 47–56, 2022, doi: <https://doi.org/10.29207/resti.v6i1.3707>.
- [16] M. D. Syamsiar, M. Rivai, and S. Suwito, "Rancang Bangun Sistem Irigasi Tanaman Otomatis Menggunakan Wireless Sensor Network," *J. Tek. ITS*, vol. 5, no. 2, 2016, doi: 10.12962/j23373539.v5i2.16512.
- [17] J. Setyowati, I., Novianto, D., Pamungkas, "Desain dan Implementasi Internet of Things untuk Smart Agriculture Irrigation," in *Seminar Nasional PENGELOLAAN SUMBER DAYA ALAM BERKESINAMBUNGAN DI KAWASAN GUNUNG BERAPI*, 2019, pp. 5–8, [Online]. Available: <https://jurnal.untidar.ac.id/index.php/lppmpmp/article/view/1843>.
- [18] M. F. Asnawi and F. Syukriasari, "A prototype for IoT based Rice Field Irrigation System," *Sinkron*, vol. 3, no. 2, p. 260, 2019, doi: 10.33395/sinkron.v3i2.10071.
- [19] R. Siskandar, M. A. Fadhil, B. R. Kusumah, I. Irmansyah, and I. Irzaman, "Internet of Things: Automatic Plant Watering System Using Android," *J. Tek. Pertan. Lampung (Journal Agric. Eng.)*, vol. 9, no. 4, p. 297, 2020, doi: 10.23960/jtep-l.v9i4.297-310.
- [20] N. Ismail *et al.*, "Smart irrigation system based on internet of things (IOT)," *J. Phys. Conf. Ser.*, vol. 1339, no. 1, 2019, doi: 10.1088/1742-6596/1339/1/012012.
- [21] M. S. Munir, I. S. Bajwa, A. Ashraf, W. Anwar, and R. Rashid, "Intelligent and Smart Irrigation System Using Edge Computing and IoT," *Complexity*, vol. 2021, 2021, doi: 10.1155/2021/6691571.
- [22] B. Queté, Al. Heideker, and I. Zyrianoff, "Understanding the tradeoffs of LoRaWAN for IoT-based Smart Irrigation," 2020, pp. 73–77.
- [23] F. Sanchez-Sutil and A. Cano-ortega, "Smart Control and Energy Efficiency in Irrigation Systems Using LoRaWAN," *Sensors*, vol. 21, no. 21, pp. 1–35, 2021.
- [24] S. Konaté, C. Li, and L. Xu, "LoRa Backscatter Automated Irrigation Approach : Reviewing and Proposed System," pp. 205–213, 2020.
- [25] Z. Xue Yuan, L. Xiao Kang, Z. LiXin, and S. Yong Chou, "Irrigation remote control system based on LoRa intelligence Irrigation remote control system based on LoRa intelligence," 2020, doi: 10.1088/1742-6596/1635/1/012067.
- [26] S. Iyer, P. Patro, R. Kapadia, A. Das, S. Cheriyan, and N. Ansari, "IoT based Cost-effective Centralised Smart Irrigation System using LoRa," 2020.