

**Enhancing Agricultural Productivity through Drone Technology:  
Design, Applications, and Outcomes - A Technical Review Report**

## **Abstract:**

Agricultural drones, are the electro-mechanical devices that are used in farming, may assist increase crop yield, and monitor its growth, among other things. These drones may be used to spray fertilizers or insecticides across a field in a consistent manner. Aerial mapping will also provide farmers with a bird's eye perspective of their fields, allowing them to swiftly spot pests, soil contamination, and growing conditions and to take corrective actions in the form of the engagement of fertilizers and pesticides. UAVs are becoming more common to meet the rising demands of agriculture for the increasing population. Drones will assist to a straightforward, efficient, and reliable production with the correct cameras, sensor, and equipment. If the offered solutions for these drones are linked into various machine learning and internet ideas, they can help enhance things even more. The work in this area is highlighted in this paper, as well as recommended solutions that may be integrated into drones utilizing the Microcontroller 8051 module's output.

## Table of Contents

<b>Abstract</b> .....	i
<b>CHAPTER 1: INTRODUCTION</b> .....	1
1.1 Overview .....	1
1.3 Research Questions: .....	4
1.4 Objectives.....	4
1.5 Significance of Study.....	4
1.6 Limitations.....	5
<b>CHAPTER 2: LITERATURE REVIEW</b> .....	6
2.1 History of Drone Development.....	6
2.2 Importance of Drones .....	7
2.3 Drones in Agriculture Industry.....	8
2.4 Agricultural Applications of Drone .....	9
2.4.1 Crop Assessment .....	9
2.4.2 Nutrient Monitoring .....	9
2.4.3 Recording the Live Stock Count.....	10
2.4.4 Disease Monitoring.....	11
2.4.5 Crop Spraying.....	11
2.4.6 Ariel Irrigation.....	11
<b>CHAPTER 3: DESIGN METHODOLOGY</b> .....	12
3.1 Flow Diagram for Drone Controlling.....	13
3.2 Flow Diagram for Spray Functioning.....	14
3.3 Hardware Interface:.....	14
3.4 Software Interoperability .....	15
3.5 Communication Interoperability .....	15
3.6 System Features .....	15
3.7 Description of components:.....	15
3.7.1 AT80C51 Board.....	15
3.7.2 ACCELEROMETER ADXL335 .....	15
3.7.3 HMC5883L MAGNETOMETER.....	16
3.7.4 SERVOMECHAICAL MOTOR .....	16
3.7.5 MODULE of WIFI ESP (8266).....	16
3.8 Working .....	16

<b>3.9 Experimental Outcomes:</b> .....	17
<b>CHAPTER 4: CONCLUSION AND RECOMMENDATIONS</b> .....	18
<b>4.1 Conclusion</b> .....	18
<b>4.2 Recommendation</b> .....	19
<b>REFERENCES</b> .....	21

LIST OF FIGURES

**Figure 1 World Hunger ..... 1**  
**Figure 2 Pesticide Spray ..... 2**  
**Figure 3 Pesticide Spray ..... 2**  
**Figure 4 Drone Functions ..... 3**  
**Figure 5 Teleautomaton ..... 6**  
**Figure 6 Amazon Prime Drone..... 7**  
**Figure 7 Livestock Monitoring by Drone..... 10**  
**Figure 8 Block Diagram of UAV based Pesticides Spraying System ..... 12**  
**Figure 9 Drone Control Flowchart ..... 13**  
**Figure 10 Spray Working Flowchart..... 14**  
**Figure 11 System Working..... 17**

## CHAPTER 1: INTRODUCTION

### 1.1 Overview:

The only consistent thing in an agriculture field is "change" itself. From the time when human started to grow his own food in the soil, he adapted several methods and practices till this day. With the development of science, mankind has developed different ways to incorporate the new technology in agriculture which can lead to increased food production in minimal time. Farmers now have to deal with issues like climate change and an ever-growing demand of agricultural outputs to satisfy global hunger (**Ahirwar et al., 2019**). According to United Nations Survey, Global population is projected to reach about 9.7 billion people in 2050, which would raise food consumption by 70 percent while decreasing the amount of land accessible for agricultural pursuits. This enormous rate of food demand urges farmers to utilize technical tools to effectively examine the agricultural data they acquire by accelerating output while ensuring quality standards for health and safety of people and environment. Moreover, farmers will have to use more sophisticated agricultural methods to be successful in the future.



**Figure 1 World Hunger**

Image from <https://www.dailysabah.com/world/2015/07/10/un-ending-world-hunger-will-cost-267-billion-per-year>

Smart Agriculture is a term that describes farmers who use modern technology to boost their agricultural and animal yields without severely impacting the quality of their products (**Al-Arab et al., 2013**). For many years, farmers have used manned airplanes to inspect their farms, administer herbicides, and check their cattle for herders, among other things.

The approximated cost to be a qualified agricultural pilot is 60 thousand dollars to 0.1 million dollars per year. To establish an effective combination of price and productivity, smart farming technology is the requirement of the present era. The usage of Unmanned Aerial Vehicles (UAV's) by farmers is on the rise. Drones are anticipated to have a positive impact on agriculture throughout the world. Despite the fact that drone technology has been around for a few years, it is expected to have a significant impact on the farming and agriculture industries. The rationale for this is because drones can presently be connected with gadgets like cameras and other data-gathering devices, thus giving farmers with an 'eye in the sky' **(Pederi and Cheporniuk, 2015)**.

Monitoring for pests and finding dry areas that may be irrigated to boost yields are some of the ways they can help. Aside from that, several nations have already begun using drones into their agricultural methods as well. In Japan, for example, pesticides are applied from unmanned helicopters sprayers on most rice fields. Farmers in the US are experimenting with drones to see if they can use them to inspect fields and find regions that are regarded to be poor because they get little water or nutrients and so enhance total production (Esposito et al., 2021). The following occurrences in the previous several years have made worldwide advancements in drone technology necessary: It's getting easier and more economical for the average citizen to own a UAV as government agencies such as the Federal Aviation Administration (FAA) loosen regulations for drone certification and use in the United States. As a result of this, the progress of unmanned drones and its use in many sectors has been boosted. However, initially, the agriculture industry is the one that took least benefit from UAV technology due to strict policies of threat of breaching the



**Figure 3 Pesticide Spray**

<https://www.grepow.com/blog/what-are-the-common-problems-with-agricultural-drone-battery/>

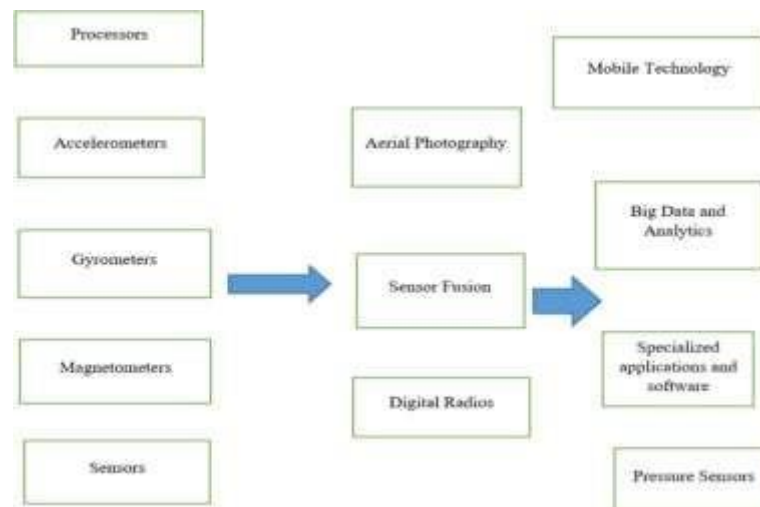

**Figure 2 Pesticide Spray**

<https://www.horticultureglobal.com/2021/08/drone-farming.html?m=1>

privacy of nearby people or security buildings, and even can cause the risk to general public (Merlin, 2021).

Upgrading the laws and regulations has had a significant influence on guaranteeing that drones are now used for the greater part of farming activities (Carvalho et al., 2020). Drones used to be synonymous with bees, which were vital to farmers' crops' pollination. As drone technology develops, farmers will be able to utilize it as a low-cost precision farming tool, giving them an aerial view of their fields that was previously only possible with expensive equipment. Historically, majority of the farmers depended on satellite or piloted aircraft photographs to monitor their crops (Fengbo et al., 2017). Drones may give farm owners with a more detailed, precise, and cost-effective view of their fields, which can be separated into workable zones. Precision agriculture requires drones with the correct equipment and knowledge. Following are mentioned some of the tools that can be applied to attain different applications from drones:



**Figure 4 Drone Functions** (NAJI, 2019)

## 1.2 Problem Statement:

As a result of changing climatic circumstances, India's agricultural worker force is shrinking rapidly. Agricultural producers employ a wide variety of farm equipment, as well as human labor to assist crop spraying. The cost of this equipment is exorbitant, and the output rate is low. As a result, agricultural technology has attracted a large number of researchers from throughout the globe. However, because to their weight, agricultural machinery functioning on the ground cannot be utilized repeatedly without causing harm to the crops or fields. In agriculture, every piece of equipment needs an operator. These machines are

only used during certain seasons and crops. Compared to other machines and workers, an Unmanned Aerial Vehicle (UAV) is more efficient, lighter in weight, and capable of working in any environment. It can be operated by a single person and doesn't require any additional human effort. It completes its tasks quickly, cheaply, and efficiently. It has a long lifespan and runs on batteries, making it environmentally friendly. Several advanced economies, like Germany, have deployed drones for spraying and other agriculture purposes.

### **1.3 Research Questions:**

1. How automatic spraying can benefit the agriculture?
2. How small-scale farmers with limited financial resources can be able to utilize the full potential of the drones?
3. Do farmers have enough technological knowledge to interpret and utilize the recorded information by drones?
4. Can drones reduce the agricultural losses and improve the agricultural practices?
5. What are the expected outcomes of the drone technology in the near future?

### **1.4 Objectives:**

1. To develop a UAV with spraying capabilities.
2. To employ sensor fusion methodology using gyroscopes and accelerometers to provide the desired direction to the aerial vehicle.
3. Implementing a control system based upon Microcontroller 8051 platform.

### **1.5 Significance of Study:**

Despite a huge amount of literature is present on how UAVs may be utilized in the farming industry, most of it is either a new initiative on a single farm or a prospective benefit that hasn't been tried and evaluated with documented findings. The study intends to evaluate some of the practical advantages as well as investigate how drones might be employed successfully in small-scale applications. It necessary to determine if drones were designed exclusively for big farms or whether they might be utilized in small farms to increase agricultural production ensuring that the practices used are cost-effective while preserving or even increasing quality standards. The article's relevance is that it adds to the existing knowledge on how drones may be employed in smart farming. It may also help governments and agricultural educators set proper standards and restrictions for drone usage in precision agriculture.

**1.6 Limitations:**

There are a few minor drawbacks to Agricultural UAV that we discovered while we working on this project. These drawbacks are detailed in the list below.

1. To make a smaller and economical UAV, flight time must be compromised to compensate the battery space and weight.
2. Its maintenance is difficult to be done by ordinary persons.
3. Lighter and stronger the material is, the more expensive it gets.

## CHAPTER 2: LITERATURE REVIEW

### 2.1 History of Drone Development:

The desire to grasp the height of skies has always motivated man to look for new methods to satisfy it. At the 1898 Electrical Exhibition, Nicola Tesla demonstrated the first radio-controlled small watercraft, which he dubbed "**Teleautomaton**". Jacques and Louis Bréguet created the first radio-controlled UAV in 1907. Tesla contributed to the development of an aerial combat UAV fleet during World War I, but the war ended before the squadron could be fully assembled. After the end of World War I, research and innovation of unmanned vehicles resumed. For training and testing purposes, the British created a number of unmanned aerial vehicle in 1935. Throughout World War II, these unmanned aircraft were widely used (**Cook, 2006**). The Fi-103, known as the Cruise Missile, was employed by Germany. In October 1944, eleven bombs were dropped on Japanese positions during the first combat operation. In 1941, the United States produced its first unmanned aircraft, the Northrop P-61, which was used to gather meteorological data for the US Weather Bureau. First turbo jet engines were utilized in the unmanned vehicles in 1951. Technology was then developed and improved to increase its output after this.

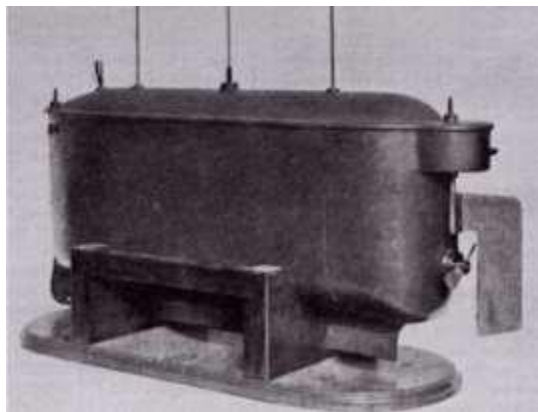

**Figure 5 Teleautomaton**

<https://www.businessinsider.com/this-famous-inventor-designed-drones-before-world-war-i-2016-8>

In 2006, government personal involved in disaster assistance, border monitoring, and forestfire suppression started to employ non-military UAVs in a more significant capacity. The use of drones for pipeline inspection and pest management on farms has also become commonplace in the industry. In addition, it is crucial to note that the Federal Aviation

Administration (FAA) of USA granted its first commercial drone licenses in 2006, and over the following eight years, it issued an average of two permits a year (**Faa.gov, 2019**). As a result of Jeff Bezos announcing in 2013 that Amazon will be contemplating the use of drones to transport goods to consumers, a public interest in drones was aroused. One thousand permits were granted by the FAA in 2015, while 3,100 licenses were granted the following year.



**Figure 6 Amazon Prime Drone**

<https://www.campaignlive.co.uk/article/amazon-plans-30-minute-delivery-drones-prime-air-service/1223302>

## 2.2 Importance of Drones:

Unmanned Aerial Vehicles are rapidly replacing the conventional and traditional ways of requiring a qualified pilot to send the aero plane in the air. Keeping in view the devastating effects of military usage of these drones, several Civil Aviation Authorities around the globe has imposed a ban or restriction for flying the UAV. These restrictions can be a possible reason to prevent any airspace collision incident. So, it is the need of time to show the nations that why UAVs must be permitted to be in the civil air, how much it can benefit the humankind and what are their application and advantages.

Border security forces, coastal security forces, rescue operations, drug dealer's pursuit, aerial photography, surveillance, and products delivered can all be possible by these drones. These are the qualities which are still unknown to several people, or they have not fully explored them. Instead of spending millions of dollars over satellites, now everyone can use a drone to have an aerial view of his requirement. Drones are fully capable of replacing the expensive and outdated satellite images. For manned aircraft, mission time and unique human considerations are the primary constraints (**Naji, I. 2019**).

Due to global warming and its negative impacts over the climate, the agriculture industry is vulnerable to any sudden incident thus effective cultivation techniques must be devised to prevent any difficulty of food shortage. The prevention lies in the acquisition of accurate and reliable data from time to time regarding the weather and crop condition for which there is a great need to develop such technology as a solution of all the problems discussed in the introduction section. Since the past decade, with the advancement in communication and imaging fields, Unmanned Aerial Vehicles (UAVs) have popped out with a huge number of applications in various industries because of its reliable data collection ability. They have been utilized effectively in a variety of industries, majorly in army, humanitarian response, and disaster management, and they are now an emerging technique in agriculture.

### **2.3 Drones in Agriculture Industry:**

Previously, farmers have employed or implemented emerging innovations like the Internet of Things (IoT), Cloud Computing, and Artificial Intelligence (AI) to manage and surpass the modifications and problems in this industry and fulfil the expanding nutritional requirements (**Meivel et al., 2016**). As a consequence of the use of these systems, agricultural methods and tools that have previously been implemented on the farms are being enhanced. To boost yields, one of the most prominent new technologies in farming is the usage of linked tractors. As compared to the other technological innovations now being utilized or used in smart or pinpoint agriculture, drones seem to be a relatively young and even less developed instrument at this point in time. The very first UAS in the farming industry were created in the 1980s for crop spraying applications. There have been a number of technological advancements in agriculture in recent times, including the accurate aerial delivery of pesticides and fertilizers and aerial imagery to help both soil and crop mapping and growth monitoring (**Shivaji et al., 2017**).

UAS are generally for short duration trips whereas solar powered UAS may persist for a prolonged capacity duration. UAS with chemical dusting, for example, has a greater carrier weight requirement and so may accommodate longer flight times (**Shantanu D. Munghate and Dr. Prashant S. Kadu, 2020**). The less investigated topic in the agriculture land of the UAS is the airborne application of water, fertilizer, and insecticides for local farmers. In 1990, Yamaha engineered and manufacture the R50UAS helicopter. The helicopter had a lift capacity of about forty-four pounds. Later in 1997, the R-MAX (unmanned helicopter) was created, and by 2000, it had been fitted with an omnidirectional

and Dynamic GPS system (**Sadeghi, Jones and Philpot, 2015**). Currently, in Japan, 90 percent of the agricultural production is done via the employment of UAVs which have eased pest management in the nation. The instance of Japan fields indicates that drones may efficiently be employed for pesticide spraying and fertilizer application for a majority of the farms in African nations.

## 2.4 Agricultural Applications of Drone:

Drones may be utilised for a wide range of agricultural implementations due to their adaptability, which we'll go over in more detail below:

### 2.4.1 Crop Assessment:

Using conventional ways to observe farmed areas takes a lot of man efforts and hours. Drones may be used to fly over the farm, take stock, and check slow-growing crops that may require more fertilizer or water to stimulate growth. This technology uses sensors to detect certain spectrum of light received and mirrored by plants, resulting in colour contrasted pictures

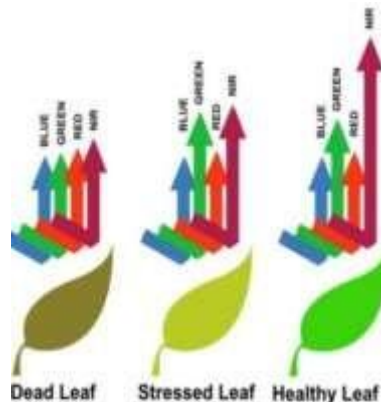

that show trouble spots in an agricultural field (**Garre and Harish, 2018**). The data collected by drones includes normalized difference vegetation index (NDVI) maps, which were previously made by satellites and aircraft by calculating the difference of near-infrared and visible light radiation.

### 2.4.2 Nutrient Monitoring:

The most important economic task in farming is to apply nutrients like sulphate and phosphorus as well as fertilisers like nitrogen, and potassium. When it comes to applying fertiliser, the farmers usually employ on the ground machines to do so, ranging from mower sprayers and pressured irrigation systems to helicopters and piloted planes

**(González Jorge et al., 2021)**. It is common practice for farmers to employ a single application rate for all of the regions being sprayed by aerial vehicles, which has a negative impact on fertiliser accuracy. In addition, the fluctuating air velocity and direction circumstances, as well as the aircraft's height shift, make precision fertiliser application practically difficult. Aerial dusting of fertiliser and insecticides is advocated in a report by (Mone, Shivaji, Tanaji, and Satish)(2017). He mentioned that according to the WHO, farm owners in underdeveloped nations apply fertiliser incorrectly in an approximately 3 million incidents of pesticide poisoning each year, resulting in 220,000 fatalities. The authors use this data to support their claims. For farmers who want to prevent the detrimental effects of fertilisers, drones may be fitted with autonomous spraying mechanisms, which guarantees that farmers get exactly what they need at the proper time and place.

#### **2.4.3 Recording the Live Stock Count:**

Drones are becoming more popular among cattlemen who have large acreages of territory to monitor their herds and inspect their fencing for damage. Drones equipped with thermal imaging cameras and night vision capabilities are also being used to inspect their farms for undesirable animals that may be preying on their cattle. At Kaziranga National Park, in India's northeastern state of Assam, the horned rhino is the primary target of human traffickers, who are being tracked by UAVs **(Bhaumik, 2013)**. In addition, ranchers are employing this technology to monitor the condition of their grasslands, which is an additional benefit.



**Figure 7 Livestock Monitoring by Drone**  
[https://www.agupdate.com/livestock/thermal-cameras-arm-drones-for-cattle-scouting/article\\_7d600208-8013-5969-8fb9-5c168a08459f.html](https://www.agupdate.com/livestock/thermal-cameras-arm-drones-for-cattle-scouting/article_7d600208-8013-5969-8fb9-5c168a08459f.html)

The airborne photos generated by the drones during pasture surveys assist ranchers to record vegetation health, height, and to monitor weather damage and places that need irrigation on the land. Additionally, the drones are utilised to herd and steer livestock throughout the farm to a certain place (**Rivas et al., 2018**).

#### **2.4.4 Disease Monitoring:**

To ensure the best possible results, farmers must frequently check the condition of their crops and look for signs of viral or fungal illness. When farmers had to personally inspect their crops, it was physical and time-consuming for the farm worker. Now, farmers don't have to travel to their fields to inspect their crops (**Rivas et al., 2018**). While this may seem like a lot of work, it's really rather simple for farmers to inspect a vast area of land in a short period of time using drones.

Drones have been tested in several regions of the globe, and the results have been positive. Using the eBee drone, farmers in Sri Lanka have been notified of diseased or pest-infested crops ten days prior than they can detect them with their own eyes (**Mwenda, 2020**).

#### **2.4.5 Crop Spraying:**

To get the most out of operating a UAV, it is crucial to keep in mind that they can quickly modify height and fly patterns in accordance with the surrounding terrain and geography thanks to extra technology like Light Detection and Ranging (LIDAR) system. Using drones for agricultural spraying has been made practical by them. They can also examine the ground and administer chemical insecticides with high accuracy in a much shorter amount of time than would be possible with a large force of physical labour (**Rivas et al., 2018**). Using drones to spray crops is supposedly five times quicker than using conventional gear.

#### **2.4.6 Ariel Irrigation:**

Modern farm owners may be able to cultivate crops utilising UAV devices as agricultural technology continues to progress. If this is realised, farmers will be able to utilise pressurized gas in the drones to discharge seed pods straight onto the agricultural area, which will dramatically cut labor expenses.

**History of Drones in Agriculture:**

Agriculture has a long and rich background that spans from its inception in prehistoric times to present times. Each of the world's regions has its own unique history of agriculture. When it comes to ancient cultures, the Middle East countries are one of them. Along with China and Central and South American agricultural development came New Guinea and sections of the eastern United States (Ayamga and Akaba, 2021). Societies based on agriculture expanded throughout the globe. The transition to a modern industrialization started with the advent of the Industrial Revolution. Growing populations compelled agricultural production to become more productive and vastly extend its reach. The green revolution is a term used to describe the use of new technology to improve efficiency.

**New Technology in Agriculture:**

When it comes to modernise farming technology, there are an expecting something in return: simpler labour, greater product quality, low cost, and sustainability are all expected. So far, nothing has been stated about the advantages of technological advancements in terms of environmental sustainability and social responsibility (Stehr, 2015). There is a wealth of research data and hands-on experience with technology, but the information is dispersed across the field.

The Sustainable Development in Agriculture with New Technologies project (2019-21), which is coordinated by the TTS Work Efficiency Society, aims to help farmland businessmen discover solutions to minimize their impact on the environment while also developing new operating procedures by spreading information and incorporating technical expertise. Combining multiple points of view results in objective knowledge and the development of a network between research, teaching, advising, and practical application (Kumar and Muhammad, 2018). The partnership involves the union of ProAgria Centers, the HAMK, and the Luke Natural Resources Center.

**Drones in Agriculture as Imaging Device:**

Photogrammetry, also known as picture measurement, includes techniques by which the geometry of an item and its attributes are studied by snapping pictures of the topic and making calculations from those photographs rather than analyzing the thing itself physically on the site of the photograph. Photogrammetry has historically been applied with the shooting of pictures of a topic; but, because to technology advancements, photogrammetry may now be used with electromagnetism and digital imaging as well. Another of the major benefits of photogrammetric measurement is that it does not tamper with even the most delicate measuring item, which is one of its significant benefits (Huuskonen and Oksanen, 2018). When the objective is too vast for topographic mapping and too

tiny for aircraft ray tracing and aerial photos, drone remote sensing employing photogrammetry is the most economical option. A number of different types of administrators exist, including aerial service providers, device makers, and computational software developers. Most systems contain of many components, including design software, the drone itself, the microcontroller, autopilot and base station with radio connections, as well as a camera and other imaging equipment. Manufacturers use a variety of flight operations technologies. It is possible for the pilot to execute both work stages personally, or the autopilot may be programmed to automatically manoeuvre the gadget into flight and again to the land. In United Kingdom, this remote mapping approach is already being utilised in agriculture to some extent, although there aren't many commercial entities to choose from. When it comes to establishing agricultural plans, a lack of competence might result in erroneous findings and, as a consequence, in making the incorrect decisions (**Iost Filho et al., 2019**). To summarise, an insufficient information may have a negative impact on the whole procedure and, under the condition, lead to economic losses. This holds true for forthcoming topics on wavelengths as well. It might be detrimental if you do not grasp what they are saying.

### **Wavelengths**

The phenomenon of remote sensing comprises of interpreting the electromagnetic radiations that are bounced back from an object. Spectra are the continuous scale of electromagnetic radiation, and they may be used in a lot of formats. When it comes to light, the wavelengths that can be seen by the human eye are just a small portion of the overall spectrum. In addition to visible range, additional spectral ranges including Ultraviolet and IR may be used for this technique (**Elarab, 2016**). Energy is reflected back, radiated into the environment, and part of it is emitted by everything. Remote sensing makes use of the characteristic spectrum. When doing a field analysis, for instance, radiation is used. As the field develops, the information provided by various wavelengths becomes more and more valuable. With the assistance of these wavelengths, you can see whether the crop is doing well and where it isn't. Near IR wavelengths, which are invisible to the naked eye, show a considerable difference between water and plants in terms of how much energy they reflect back (**Sessanna, 2019**). Much of the sun's visible light is absorbed by chlorophyll in leaves, allowing plants to perform photosynthesis. As a result, people view crops as green because they reflect so much of the green

light back into their eyes during photosynthesis.

As noted previously, not comprehending such technology and procedures might do damage. This information may be beneficial in agriculture, but if the broad picture of employing it is not transparent, there is a chance to interpret the findings inaccurately. Reviewing the information

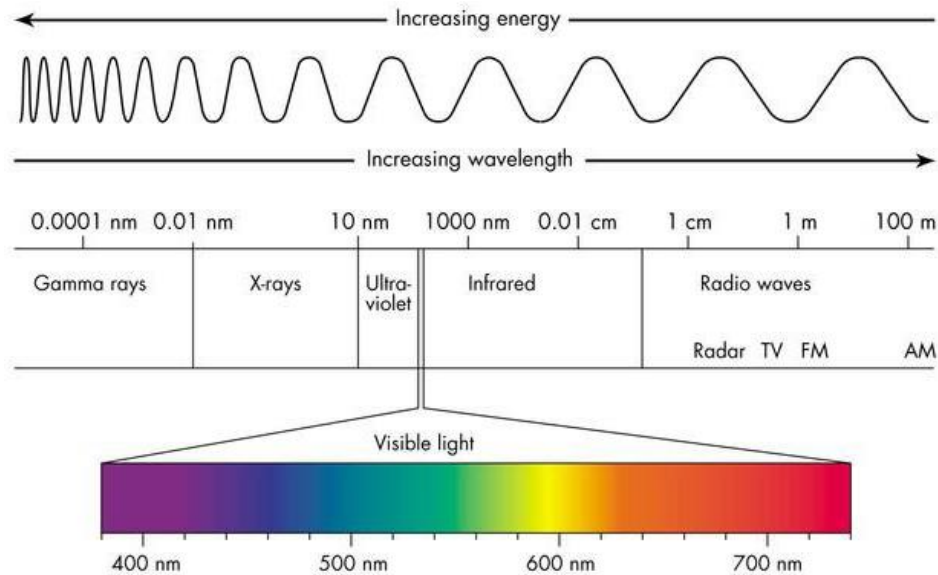

**Figure 8 EM Spectrum**

<https://www.radio2space.com/components-of-electromagnetic-spectrum/ Spectrum>

supplied by the uavs that employ these technologies may assist with irrigation and sowing for instance, however when the data is interpreted improperly this can lead to losses to ultimate quantity of produced crop.

### **NDVI Index:**

NDVI is one of the most widely used indicators worldwide to measure the increasing growth performance of green harvests. IR and visible light that is bounced back from the object is used to calculate NDVI. Near-infrared radiation is reflected more strongly by healthy, dense vegetation than by ill, patchy vegetation (Meivel and Maheswari, 2020).

$$\text{NDVI} = \frac{(\text{NIR} - \text{Red})}{(\text{NIR} + \text{Red})}$$

**VARI Index:**

It is possible to calculate the VARI merely using white light (Gitelson, Kaufman, Stark & Rundquist, 2002). No additional evidence about the harvest can be gleaned from the index; all it does is corroborate what the naked eye already knew. In a nutshell, the index determines the image's greenness (Eng et al., 2019).

$$VARI = \frac{Green - Red}{Green + Red - Blue}$$

**Ortho Aerial View:**

To create an ortho aerial picture, many images are stitched together to form a single big image. Because each location in this picture is captured from the sky, there is no viewpoint warping. Image-based measurements may be made with a good degree of accuracy, or ground geometries can be deduced (Quach et al., 2021).

**Drone beyond Imaging:**

It is now possible to make three - dimensional objects from real-world images captured by uavs, all thanks to the advancements in technology. In order to replace ageing, inefficient, and environmentally unfriendly human labour and machine operations, some corporations are developing newer, more advanced equipment. An in-depth examination of DJI, a market leader, and its new Agras T20 drone is the subject of this dissertation. Spraying and seeding are the primary functions of the drone (dji.com). Attachable tools may be used in conjunction with the drone. With the ability to connect to other equipment and exchange data, the Agras T20 may serve as a more efficient alternative to other gadgets.

**Example:**

Ready-to-fly: Agras T20 set costs around 14,000 euros, before any further fees. For instance, additional cells, canisters, and chargers might raise the price of the T20 to more than \$20,000. The T20 features conventional RTK location and radar, unlike the MG series. Using RTK, the drone's precision radar can identify objects as small as 15 centimetres at a distance of 15 metres. The Agras T20 is an agricultural and forestry-specific IP67-rated drone. An area of up to 20 hectares may be treated at a time thanks to the device's 20-liter tank. Almost a centimeter of precision may be achieved by the use of an autopilot. Using automation allows the pilot to concentrate on the task at hand, rather than just flying (Chen, Orlov-Levin and Meron, 2019). This makes it possible for a single person to operate a drone. The location of any roundabouts along the path should be included on the route's map. If you want to know where the drone won't fly, you may use the remote to revolve

around the target item. Marked regions are automatically saved in the device's internal memory and in the cloud service provided by the app. This will come in handy if the drone is ever required again. You may just go back the way you came and don't have to do anything else. Later, on a computer, you may look at the flight paths, make adjustments, and see the results improve. Drones can be tracked on a map and their FPV camera images may also be seen if you lose sight of them during flight. The drone may be called back to its starting place if you need to interrupt the flight if you are unsure. The DJI Phantom 4 RTK may also be used in tandem with the T20. In this scenario, P4 RTK creates a point cloud curve that takes into consideration the area's boundaries and barriers to the closest centimetre. Spraying with the T20 is aided by this information. A very low spray height leads in extremely good precision and little losses because of this. Because of technological advancements, these useful instruments are now accessible to the general public. Most individuals are able to fly safely and effectively with a little practise. It is based on DJI's marketing materials and research on the Agras T20 (Simula, 2021).

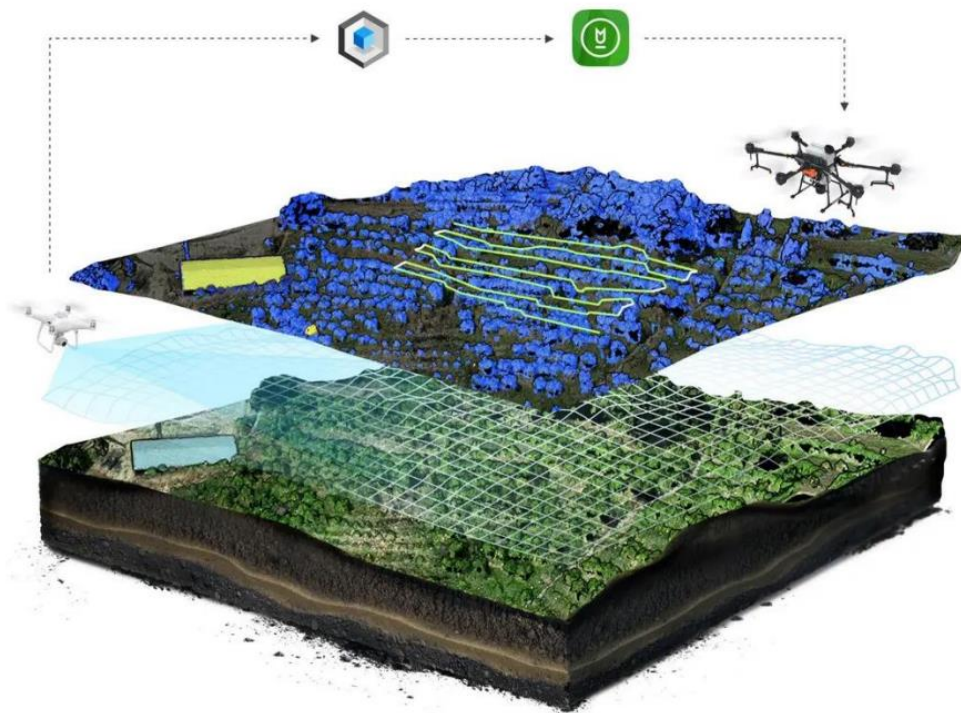

**Figure 9 T-20 Agras Field View** (Simula, 2021)

### **Technology Adaptation:**

There will always be some who have to wait a long time than others due to the advent of such cutting-edge technologies. Figure illustrates the five cycles of technological adaptation. People who are pioneers, early adopters, the majority, and the minority. When advanced innovation is presented to an audience, these are the typical processes (Venkatesh and Davis, 2000). To put it another way, it

creates an innovation lag. Once a product is introduced to the general public, it usually takes some time before it becomes widely utilised. For example, in his book "Growing the Chasm," Geoffrey Moore explains how successful technology businesses differentiate themselves from the others. A really groundbreaking modernise tech product begins as a simple concept" a trend". Introduced in Figure 4 is Moore's technology adoption cycle. It's evident. New technology has distinct effects on customers based on their demographics **Moore (2014)** provides a succinct description of each of these groups.

Technologists are relentless in their exploration of better ideas. Even before the appropriate marketing campaign has begun, people often rush to get their hands on the finished product. As a result, innovative technology plays a significant role in their lives, irrespective of what it does. Early adopters, like inventors, are quick to jump on new ideas and concepts (**Bahn, Yehya and Zurayk, 2021**). The inventors, on the other hand, are eager to put the invention through its paces before the general public has a chance to use it. The early majority is able to connect to technology, but they are logical thinkers, and hence do not purchase the first thing they see. It's common knowledge that many of these new technologies are short-lived, so they wait to see how other people are doing before they buy in. The late majority has many of the same concerns and fears as the early majority, but they also have one key difference: the late majority like to take their time, and they are probably less familiar with new technologies. Laggards make up the last group. These individuals aren't interested in the newest gadgets. There are a variety of factors, ranging from economics to stereotypes, for why a person may want to travel (**Wachenheim, Fan and Zheng, 2021**).

### **Commercial Drone Operating as a Business:**

Till today, unmanned aerial vehicles are used for a variety of applications around the globe. For few years also agriculture have gained professionals to provide reliable service to help farmers in their daily tasks. At the time, there was no well-known operator in Qatar offering this sort of service.

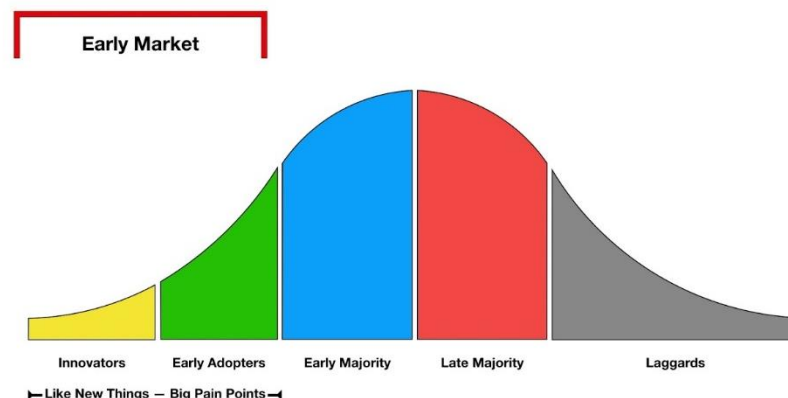

**Figure 10 Technology Adaptation Cycle (Sim, Kwon and Jung, 2016)**

These companies specialize in commercial investigations, photography, and videography in factories. This creates a new economic opportunity for both established enterprises and those just getting started in the drone market (Sim, Kwon and Jung, 2016). Agriculture drones are expected to reach a market value of \$3.7 billion by 2027, with a CAGR of 18.14 percent during the forecast period, according to **Fortune Business Insights**. New entrepreneurs developing unmanned aerial vehicles for agriculture are also expected to have a significant impact on the potential market. Farmers all over the world have reported increased productivity as a result of the use of agricultural drones, according to a report in Fortune Business Insights. Many start-ups are developing UAV solutions for farming operations because of the lucrative opportunities. In the case of Gamaya, a Swiss startup, advanced mapping and diagnostic systems are being used to improve productivity and scalability in small farms. This allows farmers to run their farms more effectively. HummingBird Technologies from the United Kingdom is another example. For smart agriculture, this startup is developing drones equipped with specially made sensing devices, artificial intelligence techniques, and computer vision that can collect precise data and imagery. Future drone farms will benefit greatly from the work of startups like these (Smalley, 2018).

## CHAPTER 3: HARDWARE AND SOFTWARE

Considering the characteristics of the various major systems was a vital part while constructing the hexacopter. This chapter identifies the component's specs and provides the logic behind its adoption.

### Framework:

The hexacopter's design is really sophisticated. The arms have plane surface which reduce the intricacies of structure and also made the structure strong at the same time. There are several replacement components, making it ideal for a prototype that will be subjected to numerous crashes throughout its testing period. With the holes carved into its arms, it is more resistant to adverse weather conditions like high winds or abrupt gusts. It's inexpensive, and its bright colors make it easy to see from a distance. Since, the drone has to face various impacts, for this reason, the structure is made up of carbon fiber, that is light weight as well as strong (Chae and Kumar, 2008).

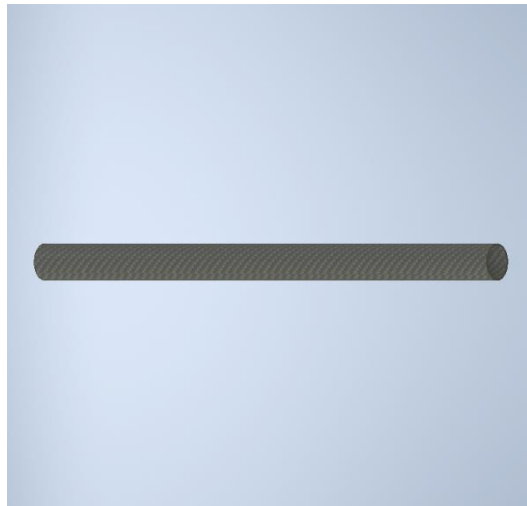

### Propellers:

The propeller's diameter may be calculated from the structure's dimensions. The diameter of our first prototype is 1100 millimetres. X and D denote the frame's width and length, respectively, while D denotes the propeller's maximum diameter. So, based on Pythagoras's theorem, the width X of a vehicle with an 1100mm wheelbase is 636.39 millimetres when calculated laterally from one motor position to the next (or 25.04 inches). In order to account for turbulence and minimise propeller collisions, a propeller size of 15 inches was the best option.

$$\frac{D}{2} = \frac{X}{2}$$

**Motors:**

In order to choose the right motor, it was necessary to know what it was going to be used for. We were able to cover more agriculture region with a single battery pack since our motors required a high thrust-to-power ratio to fly as far as feasible (V. Medeiros et al., 2018). Power was less of a consideration in the choosing of the drone since it isn't required to do quick movements. Nevertheless, a 4:1 power-to-weight ratio is a good starting point. When the six T-Motor MN605 KV170 motors' maximum thrust  $T_{tot}$  was divided by the predicted total weight  $W$ , the result was the ratio (Sasse, 2018).

$$P_r = \frac{T_{tot}}{W}$$

**Flight Controller:**

A flight control is like a neuron system of a UAV, including a gyroscope sensor for detecting movement orientations and an accelerometer sensor for reading the vehicle's pace and inclination. It's linked to the Electric Speed Controller (ESC) as both an output and an input response. The CPU placed on the motherboard, which is originally programmed by the makers, does all real-time computations. A PID Controller is an open

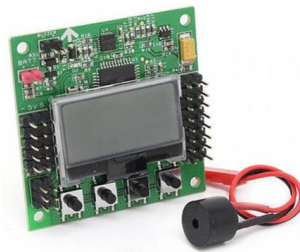

source software and programming make it one of the greatest flying consoles currently available. It has a strong 32-bit CPU, an auxiliary auxiliary controller, and a large memory space. Most accessories, such as an additional GPS or other devices, are immediately identified and installed, making configuration a breeze (Veselý and Rosinová, 2012).

### Electric Speed Controller (ESC):

In order to maintain the motor spinning, the ESC generates 3 high frequency impulses with varied yet adjustable phases. The motors may demand a lot of electricity from the ESC, thus it has a lot of current-sending capacity as well. The Quadcopter's BLDC motors need ESCs to operate. To operate the BLDC motor, the ESC connects to the receiver's control channels through an external chip. It's much more normal to think of the ESC as a pulse-width modulation (PWM) controller for the BLDC motors, which is what it does. With PWM, a BLDC motor's duty cycle may be rapidly changed from being completely off to being totally on, which is more readily expressed as a percentage. PWM is an excellent technique to regulate various contemporary electronics like this. To manage a BLDC motor's duty cycle is to control its speed with no inefficiencies and without impacting the load at the same time (Sasse, 2018).



### Radio Transmitter and Receiver:

Remotely controlling an Unmanned Aerial Vehicle is now possible with the use of a drone transmission medium, which sends radio signals to a receptor on the drone's radio antenna. A drone radio transmitter communicates across stations. An action may be transmitted to the aircraft through a different channel at any time. The four primary inputs for controlling the drone are acceleration, rudder, tilt, and roll. At the very lowest, you'll need four channels to accommodate all of them. It is the gimbals that translate the pilot's input into digital data that is relayed to the radio receiver. You may utilise either Hall effect (digital) or Potentiometer gimbals. These gimbals employ hall sensors with magnets to record stick positions, making them more durable. Additionally, these gimbals are more accurate (Nguyen et al., 2016).

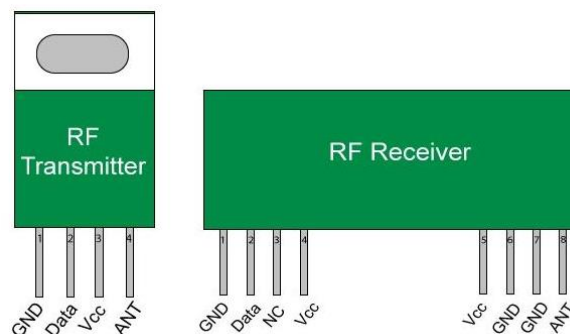

A receiver and transmitter must be of the same manufacture in order to generate a connection, which implies that a corresponding Rx and Tx must be acquired. Some radio receivers may use the same protocol yet be made by a different company. The Rx and Tx wavelengths must also be the same. However, for example, one can only use one 2.4GHz Transmitter and Receiver (**Kim et al., 2020**).

### Battery

A UAV's flight time is a major constraining element. As a result, much consideration has to be given

$$DC[A] = C_{Rating}[C] \cdot Capacity[Ah]$$

to choosing an appropriate battery. The bulk of R/C vehicles and robots are powered by Lithium Polymer batteries [20]. Additional power is absorbed in a smaller package because to their higher energy density. NiMH and NiCd batteries are the major replacements to LiPo batteries. As opposed to NiMH and NiCd cells, LiPo Battery packs have a lower lifetime. In addition, if the cells are significantly destroyed, there is a danger of fire and toxic leakage. In order to properly charge, discharge, or store a LiPo battery, you'll need to be extremely careful. Choosing a battery pack with the right discharge rate and capacity after deciding to utilise LiPos was the next step. Drone performance degrades if the battery's discharge rate (C-Rating) is too slow, resulting in poor flight performance. Increased C-Rating, on the other hand, comes with a rise in weight. Because of the additional weight, a C-Rating that is too significant will shorten the flying duration because of the additional weight (**Sasse, 2018**).



The C-Rating and Capacity attributes of a battery may be determined using the equation above. The outlet current DC of a generator is often calculated by using thrust tables given by the motor's manufacturer, as motors consume the majority of the system's power. Using the T-Motor MN605 KV170, the motor output current per motor at 75 percent throttle in a similar propeller arrangement.

To account for all of the motors, this was multiplied by four, resulting in a DC output of 64.48A. Because the drone only uses full throttle to lift off or to adjust its location during high wind gusts, the number for current consumption was set at 75% rather than 100%. The drone is more likely to fly at 40-60% throttle in hovering and cruising flight (Sasse, 2018).

### **Sprayer:**

Sprayers are the part of agricultural drone which are used to spray the pesticide. Drone sprayers can reach locations that are difficult to reach, such as steeper tea fields at higher altitudes. Workers no longer have to travel farms with backpack sprinklers, which might be dangerous to their health. Drone sprayers offer extremely fine spray treatments that can be directed to particular areas, increasing efficiency and lowering chemical costs. The sprayer system is usually placed on the lower portion of the UAV, with a nozzle below the pesticide tank to spray the pesticide downstream. The sprinkler system is made up of two modules: the sprinkler system itself and the controller. Spraying substance (pesticides or fertilisers) and a spraying nozzle are included in the sprinkling system. The second is a controller that is used to turn on the sprayer's nozzle. A pressure pump is a sprinkler system component that pressurises the insecticide so it can run through the nozzle. To pressure the pumps as needed, a motor driver integrated circuit is required.

When it comes to the performance of machinery, working capacity ( $W_c$ , ha) is a measure of how much land a piece of machinery can cover in a given length of time. Working time ( $W_t$ , h) and efficiency ( $W_e$ , ha/h) were used to determine  $W_c$  (Equation (1)). For pest control,  $sW_d$  is 14 days, and  $W_d$  is 77%, and daily working time ( $dW_t$ ) is 8 hours. Equation (2) was used to compute  $W_t$ , and the result. For each pest-control sprayer, we estimated the working width ( $W_w$ , m) as well as speed ( $W_s$ , km/h) and actual field-working rate ( $W_r$ , percent) using Equation 4. When we talk about  $W_r$ , we're referring to the ratio of real field time to all of the other time that goes into the project. If a levelled section of land was assumed, the data could be affected by factors such as farm location, road conditions and operator expertise.

$$W_c = sOT \times W_l \quad (1)$$

$$W_t = sW_d \times W_d \times dW_t \quad (2)$$

$$W_e = W_w \times W_s \times W_r \quad (3)$$

### **Cameras and Sensors**

#### **Visual Camera:**

A visual camera, known as an RGB (red, green, and blue) image sensor, may be included in certain

drone technology. These cameras, like the human eye, are capable of capturing a wide range of visual information, making them ideal for crop surveying (**Daneshpajoo, 2021**).

**Multispectral Cameras:**

Our vision can only perceive a limited number of wavelengths, whereas plants emit rays in the near infrared zone (NIR). Making 2 distinct flights with different cameras may be used to record both the visible and NIR wavelengths simultaneously. The usage of a camera with a variety of lenses is an additional choice. There are many lenses on multispectral cameras, each with a distinct filter. These filters enable the lens to concentrate on certain wavelengths, such as the near-infrared (NIR) and visible (VIS) spectrums (**Daneshpajoo, 2021**).

**Thermal Cameras:**

Thermal radiation may be measured using extended IR wavelengths. Thermal cameras can tell whether a plant is sick or under stress by observing the amount of evapo - transpiration it expends. Irrigated fields in Delaware might benefit from this. Using thermal sensors, researchers can identify hotspots and identify changes in field and crop temperature. Crop damage from droughts and/or seasonal difficulties may be detected by thermal sensors because of the cooling impact of water (**Daneshpajoo, 2021**).

**Light Detection and Ranging (LiDAR)**

LIDAR is a laser-based remote sensing system that uses the reflected light from a destination to calculate distance. Precision measurements of structures and landmasses are popular uses for LIDAR, as is the creation of realistic 3D models of a region. Lasers are used in LIDAR to determine an object's distance. Elevation data from these sensors is quite precise. Using drones to transport them is also rather costly. If you don't want to spend the money on LiDAR, you may use overlapping photos (photogrammetry) to get the same results for a fraction of the price, but with a lesser level of precision (**Daneshpajoo, 2021**).

## Software Design:

Essentially, the drone's "brain" is its software. In order to guide the uav through various node points, the software has to be developed. To understand and link all of the drone's important data together in one place. The mission planner simulation application was used to fine-tune the drone's motion and operation. The programme was set up and is now running on Windows 10 using a layer-based architecture. Drone navigation patterns, altitudes, and other essential information were correctly regulated by the right layer combination known as autopilot. The mission planner is a ground based station for aircraft, helicopters, and rovers. Microsoft Windows is the only operating system supported. As a setup tool or an adaptive control augmentation for the autopilot system, Michael Osborne's Mission Planner is a fully accessible, community-supported programme designed for the open-source APM autopilot project.

Following are the steps to setup Mission Planner Software:

- Search, download and install Mission Planner software from its official website.
- Do setup the software as per your requirement.
- Fetch ardupilot mission planner firmware.
- Establish the connection between the operating system and ardupilot using the mission planner software.
- Extract and run the firmware to ardupilot.

## Configuration and Calibration Procedure

The frame class and type configuration for the hexacopter are as follows:

- The first step is to choose an initial setup
- Select the hardware configuration
- Continue with the default type X.
- If you're working with a physical frame, make sure that the specifications for class and kind of frame match with your physical drone design. Fig. 7 shows the various frame arrangement.

The flight mode configuration is done as follows:

- Turn the switch of radio control transmitter to ON position
- Create a wireless connection of mission planner with the flight controllers

- Enter into Initial Setup, select the option "Mandatory Hardware" and then go to flight mode screen
- Choose the flight mode for each position of switch
- At the very least, define a stabiliser switch position.
- Simple mode should be selected for the switch position.
- Press the save modes button when you're finished. Figure 8 depicts the flying mode set up.

The radio calibration is done as follows:

- Click on "Initial Setup"
- Go to Mandatory hardware. This time a page will appear showing the radio calibration options.
- Select the calibration option.
- A popup will appear for the verification that the radio equipment is ON, propellers are still not attached and the batteries are still unoperational. Respond accordingly
- Rotate, push or pull the control sticks or knobs to minimum and maximum positions.

Flight mode calibration are done as follows

- Go to Mandatory hardware bar and acceleration option.
- Start the calibration
- In order for the drone to be positioned in each calibrating position, the mission planner recommends to hold the drone in every possible direction.
- Activate the automatic pilot by pressing any button and then move to the next configuration.
- Straight, right hand side, left side, straight down and pitch up and on its back are the calibration locations.
- Hit when down after you've achieved each needed position and kept steady. • The software will indicate calibration completion after the calibration procedure is done.

## Methodology:

### Drone Parameters:

Unmanned aerial vehicles have mostly been employed for remote sensing and picture collection in precision agriculture. Drones, on the other hand, may be used to collect data from nodes in the ground. The vehicle's flight plan will be determined by its intended function. In order for an uav to contain a gateway node, the drone must stay in the node's coverage area long sufficient for all of the information to be communicated. A linear flight plan with the nodes flying over may work for tiny quantities of data. For large volumes of data, however, scheduled flights in which the drone circles the node until all of the statistics is transferred that is required (Popescu et al., 2020). These two kinds of flight patterns are shown in Figure 1. The flight route directs the UAV to fly over the nodes in a linear pathway. For a fixed-wing drone, that usually encircles the field for data collection, a flight plan for drone includes hovering above the nodes would address the issue of not having adequate connectivity time to complete the attachment and send all of the data prior the node is out of the drone's service region.

### Low Cost Nodes for Precision Agriculture:

Currently, a broad range of price-effective nodes that may be used for PA via WiFi connectivity are available. Table 2 lists some of the most often used ones. Inexpensive nodes are used for both field observation and the gateway installed on the uav in the scenario described in this article. The features of the nodes may vary substantially, as can be observed. The load and dimensions of the nodes should be assessed to see whether they will hinder the drone's flying or if it can take the node without

Controller	FLASH	RAM	EEPROM	Weight	Size	Operating Voltage
WEMOS MINI D1	4 MB	-	-	3 g	34.2 × 25.6 mm	3.3 V
Node MCU	4 MB	520 kB	-	10 g	48 × 26 × 11.5 mm	3.3 V
Arduino Mega	256 kB	8 kB	4 kB	37 g	101.52 × 53.3 mm	5 V
Arduino UNO	32 kB	2 kB	1 kB	25 g	68.6 × 53.4 mm	7–12 V
Raspberry Pi 3 Model B+	-	1 GB	-	50 g	85 × 56 × 17 mm	5 V

interrupting with it. If no sensors are attached to the drone's node and a huge processing capability is not required, nodes like the WEMOS MINI D1 are the ideal option for reducing energy usage owing to their small size and weight.

Other wireless devices, such as LoRa and 5G, might minimise or remove the requirement for drones for data collecting in tiny places owing to their greater range. However, since these innovations are more expensive, they are out of reach for landowners with little resources. Multiple characteristics,

such as transmission power, protocol, and link budget, may also impact the network infrastructure. In terms of the transmission power parameter, it would have a significant impact on drone coverage since it would spend more energy and have a lower flying potential. Using alternative procedures would change the overall connection time since the connectivity time required between the nodes and the drone may be adjusted based on the transformations between multiple states, which are related with the activities performed by the nodes. The link budget, on the other hand, would be defined as the sum of transferred power and profits minus losses. The received power is determined by the losses incurred as the signal travels through the environment, which may be influenced by factors like as climate or obstacles that block the sightlines between the transmitter and the receiver. Nevertheless, there are no obstructions between the transmitter and the receiver in the examined case, and the drone would not fly in bad weather. As a result, the losses would be consistent in this situation. Finally, since the sent power and gains are determined by the antennas and their arrangement, they will not alter until various kinds of antennas or nodes with different configurations are utilised to boost the transmitted signal (**García et al., 2020**).

#### **Antenna Radiation Model:**

The 2.4 GHz band may be transmitted using a variety of antennas. Nevertheless, not all of them are recommended for use with a drone-borne gateway. Two antennas for area coverage are shown in the diagram. Each antennas' common radiation patterns are also depicted. For the sake of this situation, the gateway node is assumed to be transported by the UAV and positioned such that the antenna releases its radiation downhill, toward the ground. The emitted energy from a directional antenna is concentrated in a certain path. The transmission length improves as the strength of a directional antenna increases, while the practical angle of coverage drops. Omni - directional antennas, on contrary hand, have a radiation characteristics determined by the directed gain. In one of the datum planes, this antenna produces homogeneous emissions. In terms of directivity, omnidirectional antennas are more suitable for the circumstance than directional antennas since they enable the station to stay in the gateway's service area for a longer period of time. In other circumstances, such as a flight plan that circles grounded nodes, directional antennas would be a better match since the uav could stay in a region where the node is within the communication range and the emitted energy would stay on the targeted point. The antennas may also be polarised linearly or circularly. The communication range of polarization varies depending on the kind. To reduce losses, the polarisation of the antennas from the emitter and receiver should match. The transmitters of the gateway node on the drone and the nodes on the ground are situated in the same horizontal position and have the same

polarisation in our situation.

Certain low-cost nodes include built-in WiFi antennae, such as the PCB antenna, whilst others need a communication module or an external antenna, such as a whip antenna, to give greater functionality.

The area of reportage is determined by the gain of the antenna and the transmission system abilities. As a result, figuring out how far the antenna needs to reach is critical. Price economical modules with RSSI values under 85 decibels and the finest module with RSSI values up to 125 m have used the built-in printed circuit board antenna for lengths up to 30 m in IoT applications. Antennae that have a whip shape are preferable for high-flying drones because they can scan more area, but they are larger and must be arranged in a way to avoid interfering with their flight route. The gateway in the unmanned aerial vehicles emits radiation in a manner similar to that of a sphere when seen from the node in the ground. We may utilise a trigonometrical problem based on this assumption to determine the length of time that a single node is connected to the mobile gateway wirelessly in various circumstances like flight height, velocities etc.

Sagitta of circular arc is a widely adopted concept for optics. It is defined as the total distance between the centers of the arc to the center of the base. The mathematic equation can be written as:

$$s = r - ap$$

$$s = r - \sqrt{r^2 - \left(\frac{c}{2}\right)^2}$$

$$s = r \times \text{versin} \frac{\alpha}{2} = r \times \left(1 - \cos\left(\frac{\alpha}{2}\right)\right)$$

To calculate the time in which a single node has coverage from gateway mounted on the UAV.

$$dc - fh = dc - \sqrt{dc^2 - \left(\frac{c}{2}\right)^2}$$

$$c = 2\sqrt{dc^2 - (-fh)^2}$$

$$t = \frac{2\sqrt{dc^2 - (-fh)^2}}{dv}$$

## System Description

One of the major issues in the situation under consideration is that the uavs may collide with sensor network inside the drone's coverage areas. To address this issue, we suggest a data gathering system for precision agricultural installations in this section, in which the sensor nodes send data to a single mobile gateway installed on a remote sensing drone. The unique agricultural production scenario's architecture is also explored.

### Architecture:

There are 4 layers to the smart farming design. The bottom most layer is the Sensors Node Layer. This layer contains all of the sensor devices that have been installed in the fields. The Drone Layer sits just over the sensor node layer. It consists of the drone fitted with remote sensing gear, which takes pictures of the plants and gathers data from the nodes through its wireless link, the access point location, the IT equipment, which stores the data the drone acquired while flying, and the networking hardware, which let us access to the Internet. A Service Provider is used to for the connection to internet. Based on the position of a farm's agricultural fields, a farmer may choose between cable and wireless Internet connections, relying on which method is most convenient. The Internet layer is the next layer below. Data is sent to a distant site for processing via the Internet, which the Operator uses to connect to a network. A Virtual Private Network (VPN) is used to access to the distant site. When travelling over the Internet, the information will be more secure in this manner. Lastly, we have a distant Data Center Layer, which is where we save all of our collected data. In order to assure optimum planning, this data may be analysed using artificial intelligence (AI).

**Algorithm:**

An array of sensor nodes is set up over a variety of agriculture land in the precision agriculture scenario. The nodes don't form any kind of system structure. As a result, the nodes are unable to interact with one another. Relay nodes placed in between the soil surveillance networks might solve this issue, however this approach greatly increases deployment costs, especially for dense sensor networks where considerable span separate the sensors. A variety of sensors are included into the nodes to collect data on the physical properties of the plants that may be used for crop management and tracking. An integrated antenna may be used to connect with the node, as shown in Table 2, or a specific communication module from those on the marketplace can be required. Until the remote sensing hexacopter gathers the data, the data are kept on SD cards linked to each node using a drone equipped with moisture levels and temperature sensors, an example may be shown in Figure 5. The path starts and finishes at the ground dock, where the uav is stationed. On the way, the uav captures pictures of the farms and the surrounding area. For further analysis, all gathered information is sent to a data centre when the drone arrives at its destination at the ground station. One of the prerequisites of a precision agriculture system that uses a uav to acquire data from sensor nodes placed on the ground is a high-quality link between the sensor node and the drone. Improving energy efficiency, accessibility of operating frequencies, and clear and stable weather patterns are also necessary to minimise signal loss or damage to the drone and sensor nodes. Efforts should be made to reduce the drone's and sensor nodes' power usage. To save power, the sensor nodes may be put to sleep when not in use. When the drone is flying over the sensor nodes, the nodes may be activated at a predetermined time so that they don't go into idle mode when the drone passes over them. If energy usage and battery selection are improved, sensor nodes' lifespans may go much beyond a year. Rechargeable batteries sensor nodes might almost be eliminated if solar panels were used to power them. The kind of harvest or the intended sensor node length and width would dictate which method of powering the sensor would be best. Forests continue to produce each year without the need to plant new ones, whereas other crops are allowed to rest in the field until the next year's planting season. It is thus possible to adjust or delete the nodes depending on the kind of agriculture and its features. Finally, although harsh weather conditions are inevitable, there are steps that may be done to lessen the potential harm that the precision agriculture system's components might inflict. It is possible for a drone to determine if it is airworthy if a weather station is integrated into the precision agriculture. Waterproof wrapping and the ability to retain data for many days are necessary to guarantee that no data is lost from the sensor nodes. Due to harsh weather conditions, SD cards in

sensor network would allow for manual data retrieval, even if a drone was lost. Figure 6 depicts the drone's working algorithm. When a flight plan has been built utilising the current software for flight plan designs and crop needs, the drone loads the flight plan into memory. The meteorological station's data is requested by the drone once it has been set up. As soon as the threshold value (wth) is exceeded, all flights are postponed until the next available window. Thereafter, the quantity of rain is determined. The flight is also halted if the threshold value is exceeded. If all is OK, the drone will check the amount of power it has. The drone starts its journey across the fields if there is sufficient energy. The drone will abort a flight if it doesn't have enough power. The drone will then see whether any nodes are requesting connections. A snapshot of the crop is taken and the amount of energy is re-evaluated if there is no node to connect with. In order for the drone to gather information, a node has to be found. To signify that a successful connection has been established and the node should go into sleep mode and not attempt to reestablish contact with the drone for the duration specified in the parameters, the drone sends a disconnect message. The drone avoids any interferences from other nodes that may be placed in the area covered by the drone. Drones send their data to a distant database for additional analysis after the path has been established at the ground station. It then waits for the next flight time to arrive at the station before taking off again. There are nodes that may identify beacons sent by the drone and ask for a connection. Data is sent from a node to a drone when the link is established. It then sends an ACK and a Disconnect message to let the node know that it's time to put the node to sleep for the specified amount of time. When the drone receives an ACK from the node, it means that the Disconnect message was received successfully. Throughout the course of the drone's flight, all of the nodes it deploys on the field are reactivated. The data are sent to the database when the node reaches the base station, and the server acknowledges the arrival of the data by sending an ACK message to the node.

## **Results and Discussion:**

### **Performance Test:**

Prior the whole system was assembled, the fabrication was verified and the functioning was observed; anytime a problem arose, it was corrected. Drone functionality was as expected since the load on the uav was substantial, making the total weight of the drone less and so reducing the fly duration, which in turn reduced the burden. A computer system running the calibration software was used to accurately tune the controllers (Pixhawk). Each element was put through its paces to ensure that it performed in accordance with industry standards. Once the undercarriage had been verified to be securely attached to the drone, the drone was prepared for its maiden flight. This flight demonstrated that the drone's design had been successful, since it maintained its stability no matter what the weather conditions were.

### **Connectivity:**

To begin, we need to think about the amount of time it will take to create the communication. We conducted real-world testing to find out how long it takes Microcontroller nodes to establish a connection with each other. Results indicated that connection formation times ranged from 3 - 4 seconds. Considering a worst-case scenario with an access time of four seconds to guarantee that all nodes are connected. Due to the fact that data is sent after the connection has been established, we'll allocate 5 seconds to the process of establishing the connection and sending the data. Because of this, any dc/fh combination that results in a time in coverage of less than or equal to 5 s is deemed impossible for connectivity. Because such WiFi speeds have been getting faster over the past few years and sensors only send small amounts of data, we can assume that all the details can be sent in 5 seconds.

Concerning the concentration of nodes, we need to think about how many nodes can interact to the UAV in one time and have to start sharing their time in reportage. In smart farming, there is more than one way to look at node density. Most of the problems are caused by intensive farming of strawberry trees, like orchards. Growers used to put one tree every 16 to 20 m<sup>2</sup> when they grew trees. If each tree has one node, then there will be one node for every 16 to 20 m<sup>2</sup>. Still, this doesn't happen often because the soil conditions and irrigation methods are pretty similar. So, we can guess that in the most populated network infrastructures. Grain or energy crops can be used in other situations. In these situations, the farms cover the soil evenly, making it impossible to tell which plant is which. Also, because these crops don't produce as much as fruit-bearing trees, the amount of money spent on smart farming is less. Also, if we think about the fact that most cereals and energy

crops don't need watering, we can lower the number of nodes even more. In these situations, it is not too much of an exaggeration to say that there can be only one node in each field, even if there is one node for every 5000 m<sup>2</sup> or more. In between these two cases, there is another example of a tree that bears fruit, such as an olive tree. There aren't as many trees in the field as there are in orchards. Also, since there are no watering processes used to grow olive trees, there is less need to keep an eye on them. So, we can expect one node every 750 m<sup>2</sup> when this type of crop is being grown. Still, the farmer will be in charge of deciding the final density. When deciding how close together the nodes will be, the farmer will look at natural conditions like soil quality, terrain uniformity, and past climate events. He or she will also look at cultural factors like crop resilience, irrigation needs, and susceptibility to certain illnesses or pests.

#### **Flight Time with Payload Test:**

The Remote Controlled transmitter and a computer may both be used to do this test, by adjusting the sensitivity of the actuators to match one another. This prevents any unwanted vibrations that may interfere with the plane's flying path. By balancing all the rotors to move at the same speed, this prevents the hexacopter's brushless motors from vibrating, which might lead to an incorrect trajectory. All of the sensors and drone parts that are employed have been precisely calibrated. A standard model is used to calibrate the whole hexacopter drone system, including the microcontroller. These are the numerous drone system calibrations that were completed. After the assessment, all faults were fixed to verify that the system responds efficiently to its commands. The new hexacopter is more effective than its predecessors. The most significant benefit of the drone is that it may be tailored to the task at hand.

#### **Effects of Payload on Takeoff:**

Throughout the test, the following results were discovered about the payload capacity of the uav. When a freight of 5 kg was introduced, the drone was unable to fly properly; when a payload of 3.5 kg was added, it was also unable to fly well. This demonstrated that the proportional system would provide less thrust when the combined weight of the drone and payload exceeds the thrust.

<b>SR</b>	<b>PAYLOAD</b>	<b>TOTAL WIEGHT</b>	<b>ABILITY TO FLY</b>
<b>1</b>	0	2.06	3 (Good)
<b>2</b>	2.75	4.81	3 (Good)
<b>3</b>	2.92	4.98	1 (Poor)
<b>4</b>	3.25	5.31	1 (Poor)
<b>5</b>	3.65	5.71	2 (Fail)

Duration of uav flying duration for various payloads as determined by test results is summarised below. Table showed that the drone flying time decreased as the payload increased. This experiment demonstrated that the drone's flying time decreased with increasing weight and conversely.

<b>SR</b>	<b>PAYLOAD</b>	<b>TOTAL WEIGHT</b>	<b>FLIGHT TIME</b>
<b>1</b>	0	2.06	32 min
<b>2</b>	2.75	4.81	14 min
<b>3</b>	2.92	4.98	13 min
<b>4</b>	3.25	5.31	12 min
<b>5</b>	3.65	5.71	11 min

## CHAPTER 4: CONCLUSION AND RECOMMENDATIONS

### 4.1 Conclusion:

In this paper, we have reviewed the study about how to use a drone to splatter pesticides and fertilizer on crops. This technique of putting chemicals on farm areas cuts down on the number of people who must do it, how long it takes, and how much it costs. If you are a farmer and you want to cut down on the amount of work you do, this UAV can help you move agrochemicals across your land, so you don't have to do as much work. People who work for farmers can use this app on their phones to manage the UAV. The drone also has a Wi-Fi module that lets them connect to their phones. The spraying drone accurately sprays pesticide on the soil of the farmer who owns it, no matter how big or small the field is or what kind of crops are grown there. An electrical board called the 8051 has also been used to connect the Wi-Fi module to a Global Positioning System. This panel is a common platform for making prototypes. Hentschke et al., (2018) employ ACCELEROMETER GYRO and MAGNETOMETER to make sure that the UAV is balanced from all positions. a cordless webcam that lets the farmer send and get HD pictures and videos. Chemical spraying can be done with the help of the wireless sensor nodes that are positioned at the ground level in the field at the spot where the toxicant (pesticide) is to be sprayed **(Mhetre, P.S., Soni, D., Nerkar, A. and Vishal, H. ,2019)**. The correct algorithm and its response principle are used to change the UAV locations based on changes in the air velocity. Depending on the weight of the UAV and how high it is, pesticide spraying, water use, and other costs could be cut by 20% to 90%.

## **4.2 Recommendation:**

The development of a functioning autopilot is an essential future step in making the technology more dependable and autonomous, leading in a more optimum functioning. Experiments can be carried out on smaller fields, containing just a few affected plants, so that a learning process can take place by way of hit or miss. Moreover, more drones should be tested to see whether they have a positive impact. It seems unlikely that a single drone could treat all the diseased crops and problems, depending on flight time data and the time required to inject pesticides into a single field. Using a fleet of drones, the epidemic may be brought under control more quickly. This will save you time and money in the long term.

Because of a large-scale agriculture system in the world, educating the farmers about the pros of drone technology must be the most crucial step in the success of this venture. It is important to evaluate the optimization of present system components. However, even if prototype drones were built with "good enough" components, employing optimum components will result in much better performance. Even though this is a high-cost area, the use of cutting-edge technology will elevate the project's appeal and make it more attractive to potential investors and funders.

Finally, for the future of this research, different surveys will be undertaken to know about what farmers think about the technological agriculture, what are their concerns and what kind of support they need to start entering this technology. After gathering the relevant information and collecting data. A report will be written on how to support traditional farmers to the new technology and changing the old farming methods to modern methods using this technology. A set of policies must be induced to meet all the requirements of the farmers including education, technical and financial needs.

## REFERENCES

- Ahirwar, S., Swarnkar, R., Bhukya, S. and Namwade, G. (2019). Application of Drone in Agriculture. *International Journal of Current Microbiology and Applied Sciences*, 8(01), pp.2500–2505.
- Ayamga, M. and Akaba, S. (2021). Multifaceted applicability of drones: A review. *Technological Forecasting and Social Change*, [online] 167, p.120677. doi:10.1016/j.techfore.2021.120677
- Al-Arab, M., Torres-Rua, A., Ticlavilca, A., Jensen, A. and McKee, M. (2013). Use of high-resolution multispectral imagery from an unmanned aerial vehicle in precision agriculture. *2013 IEEE International Geoscience and Remote Sensing Symposium - IGARSS*.
- Ashok, R. (2020). *Drones to aid date palm farming in Oman*. [online] gulfnews.com. Available at: <https://gulfnews.com/world/gulf/oman/drones-to-aid-date-palm-farming-in-oman-1.77335915>>
- Bhaumik, S. (2013). *India deploys drones to save rhinos in Assam state*. [online] BBC News. Available at: <https://www.bbc.com/news/world-asia-india-22075311>.
- Cook, K. (2006). The Silent Force Multiplier: The History and Role of UAVs in Warfare. *IEEEAC*, 1.
- Carvalho, F.K., Chechetto, R.G., Mota, A.A.B. and Antuniassi, U.R. (2020). Challenges of Aircraft and Drone Spray Applications. *Outlooks on Pest Management*, 31(2), pp.83–88.
- Bahn, R.A., Yehya, A.A.K. and Zurayk, R. (2021). Digitalization for Sustainable Agri-Food Systems: Potential, Status, and Risks for the MENA Region. *Sustainability*, 13(6), p.3223. doi:10.3390/su13063223
- Chavan, M. (2019). Automatic Aerial Vehicle Based Pesticides Spraying System for Crops. *International Journal of Innovative Technology and Exploring Engineering*, 8(11), pp.41–44.
- Chae, H.G. and Kumar, S. (2008). Making Strong Fibers. *Science*, 319(5865), pp.908–909. doi:10.1126/science.1153911.
- Chen, A., Orlov-Levin, V. and Meron, M. (2019). Applying high-resolution visible-channel aerial imaging of crop canopy to precision irrigation management. *Agricultural Water Management*, 216, pp.196–205. doi:10.1016/j.agwat.2019.02.017.

Casella, V., Chiabrando, F., Franzini, M. and Manzano, A.M. (2020). Accuracy Assessment of a UAV Block by Different Software Packages, Processing Schemes and Validation Strategies. *ISPRS International Journal of Geo-Information*, 9(3), p.164.

<https://www.dji.com/search?q=agras>

Daneshpajoo, E. (2021). INTERNSHIP REPORT DESIGN OF A MULTI-PURPOSE AGRECULTURE DRONE. *ResearchGate*.

Esposito, M., Crimaldi, M., Cirillo, V., Sarghini, F. and Maggio, A. (2021). Drone and sensor technology for sustainable weed management: a review. *Chemical and Biological Technologies in Agriculture*, 8(1).

Fengbo, Y., Xinyu, X., Ling, Z. and Zhu, S. (2017). Numerical simulation and experimental verification on downwash air flow of six-rotor agricultural unmanned aerial vehicle in hover. *International Journal of Agricultural and Biological Engineering*, 10(4), pp.41–53.

Faa.gov. (2019). *Public Safety and Government*. [online] Available at: [https://www.faa.gov/uas/public\\_safety\\_gov/](https://www.faa.gov/uas/public_safety_gov/).

- Garre, P. and Harish, A. (2018). Autonomous Agricultural Pesticide Spraying UAV. *IOP Conference Series: Materials Science and Engineering*, 455, p.012030.
- González Jorge, H., González de Santos, L.M., Fariñas Álvarez, N., Martínez Sánchez, J. and Navarro Medina, F. (2021). Operational Study of Drone Spraying Application for the Disinfection of Surfaces against the COVID-19 Pandemic. *Drones*, [online] 5(1), p.18.
- Hentschke, M., Pignaton de Freitas, E., Hennig, C. and Girardi da Veiga, I. (2018). Evaluation of Altitude Sensors for a Crop Spraying Drone. *Drones*, 2(3), p.25.
- Elarab, M. (2016). The Application of Unmanned Aerial Vehicle to Precision The Application of Unmanned Aerial Vehicle to Precision Agriculture: Chlorophyll, Nitrogen, and Evapotranspiration Agriculture: Chlorophyll, Nitrogen, and Evapotranspiration Estimation Estimation. [online] Available at: <https://digitalcommons.usu.edu/cgi/viewcontent.cgi?article=5918&context=etd>
- Eng, L.S., Ismail, R., Hashim, W. and Baharum, A. (2019). The Use of VARI, GLI, and VIgreen Formulas in Detecting Vegetation In aerial Images. *International Journal of Technology*, 10(7), p.1385. doi:10.14716/ijtech.v10i7.3275
- García, L., Parra, L., Jimenez, J.M., Lloret, J., Mauri, P.V. and Lorenz, P. (2020). DronAway: A Proposal on the Use of Remote Sensing Drones as Mobile Gateway for WSN in Precision Agriculture. *Applied Sciences*, 10(19), p.6668. doi:10.3390/app10196668.
- Huuskonen, J. and Oksanen, T. (2018). Soil sampling with drones and augmented reality in precision agriculture. *Computers and Electronics in Agriculture*, 154, pp.25–35. doi:10.1016/j.compag.2018.08.039.
- lost Filho, F.H., Heldens, W.B., Kong, Z. and de Lange, E.S. (2019). Drones: Innovative Technology for Use in Precision Pest Management. *Journal of Economic Entomology*. [online] doi:10.1093/jee/toz268.
- Koruba, Z. (2004). Gyroscope-based control and stabilization of unmanned aerial mini-vehicle (mini-UAV). *ResearchGate*, 9(2), pp.10–16.
- Kumar, A. and Muhammad, B. (2018). On how internet of drones is going to revolutionise the technology application and business paradigms. [online] IEEE Xplore. doi:10.1109/WPMC.2018.8713052.
- Kim, K.-S., Yoo, J.-S., Kim, J.-W., Kim, S., Yu, J.-W. and Lee, H.L. (2020). All-Around Beam Switched Antenna With Dual Polarization for Drone Communications. *IEEE*

*Transactions on Antennas and Propagation*, 68(6), pp.4930–4934.

doi:10.1109/tap.2019.2952006.

Merlin (2021). *Drone Laws in the Sultanate of Oman*. [online] Drone Laws. Available at: <https://drone-laws.com/drone-laws-in-the-sultanate-of-oman/>.

Moore, G.A. (2014). *Crossing the Chasm : Marketing and Selling Disruptive Products to Mainstream Customers*. New York: Collins Business Essentials.

Meivel, S., Dinakaran, K., Gandhiraj, N. and Srinivasan, M. (2016). Remote sensing for UREA Spraying Agricultural (UAV) system. *2016 3rd International Conference on Advanced Computing and Communication Systems (ICACCS)*.

Mhetre, P.S., Soni, D., Nerkar, A. and Vishal, H. (2019). AGRICULTURE DRONE FOR FERTILIZER SPRAYING. *International Research Journal of Modernization in Engineering Technology and Science*, 2(6).

Mwenda, A. (2020). *Drone agriculture spraying in Sri Lanka*. Drone Economy.

NAJI, I. (2019). *THE DRONES' IMPACT ON PRECISION AGRICULTURE*. THESIS.

Nguyen, P., Ravindranatha, M., Nguyen, A., Han, R. and Vu, T. (2016). Investigating Cost-effective RF-based Detection of Drones. *Proceedings of the 2nd Workshop on Micro Aerial Vehicle Networks, Systems, and Applications for Civilian Use*. doi:10.1145/2935620.2935632.

Pederi, Y.A. and Cheporniuk, H.S. (2015). Unmanned Aerial Vehicles and New Technological Methods of Monitoring and Crop Protection in Precision Agriculture. *IEEE 3rd International Conference Actual Problems of Unmanned Aerial Vehicles Developments (APUAVD) Proceedings*, pp.298–301.

Popescu, D., Stoican, F., Stamatescu, G., Ichim, L. and Dragana, C. (2020). Advanced UAV–WSN System for Intelligent Monitoring in Precision Agriculture. *Sensors*, 20(3), p.817. doi:10.3390/s20030817.

Quach, C.H., Pham, M.T., Nguyen, T.S. and Phung, M.D. (2021). Real-time Agriculture Field Monitoring Using IoT-based Sensors and Unmanned Aerial Vehicles. 2021 8th NAFOSTED Conference on Information and Computer Science (NICS). doi:10.1109/nics54270.2021.9701498.

Rivas, A., Chamoso, P., González-Briones, A. and Corchado, J.M. (2018). Detection of Cattle Using Drones and Convolutional Neural Networks. *Sensors*, [online] 18(7), p.2048.

Shivaji, C., Tanaji, J., Satish, N. and Mone, P.P. (2017). AGRICULTURE DRONE FOR SPRAYING FERTILIZER AND PESTICIDES. *International Journal for Research Trends*

*and Innovation*, 2(6).

Stehr, N.J. (2015). Drones: The Newest Technology for Precision Agriculture. *Natural Sciences Education*, 44(1), p.89. doi:10.4195/nse2015.04.0772.

Shantanu D. Munghate and Dr. Prashant S. Kadu (2020). Design and Development of Agricultural Spraying Drone: Spraying System and Tank. *International Journal for Modern Trends in Science and Technology*, (8), pp.221–232.

Simula, A. (2021). Establishing drone technology to agriculture as a service provider.

- Soni, D., Nerkar, A. and Vishal, H. (2018). AGRICULTURE DRONE FOR FERTILIZER SPRAYING. *International Research Journal of Modernization in Engineering Technology and Science*, 2(6).
- Sim, S., Kwon, H. and Jung, H. (2016). A Study on Utilization of Drone for Public Sector by Analysis of Drone Industry. *Journal of the Korea society of IT services*, 15(4), pp.25–39. doi:10.9716/kits.2016.15.4.025.
- Sadeghi, M., Jones, S.B. and Philpot, W.D. (2015). A linear physically-based model for remote sensing of soil moisture using short wave infrared bands. *Remote Sensing of Environment*, 164, pp.66–76.
- Smalley, E. (2018). In silico farming drives next wave in agriculture. *Nature Biotechnology*, 36(9), pp.783–784. doi:10.1038/nbt0918-783a.
- Sessanna, R. (2019). Capturing and analyzing multispectr Capturing and analyzing multispectral UAV imager V imagery to delineate o delineate submerged aquatic vegetation on a small urban stream. THESIS.
- Sasse, F. (2018). *Drone Based Control of Pine Processionary Moth Outbreaks in Mediterranean Woodlands*. THESIS.
- United Nations (2019). *Growing at a slower pace, world population is expected to reach 9.7 billion in 2050 and could peak at nearly 11 billion around 2100 | UN DESA | United Nations Department of Economic and Social Affairs*. [online] UN DESA | United Nations Department of Economic and Social Affairs. Available at: <https://www.un.org/development/desa/en/news/population/world-population-prospects-2019.html>
- Venkatesh, V. and Davis, F.D. (2000). A Theoretical Extension of the Technology Acceptance Model: Four Longitudinal Field Studies. *Management Science*, 46(2), pp.186–204. doi:10.1287/mnsc.46.2.186.11926
- V. Medeiros, R., G. S. Ramos, J., Nascimento, T., C. Lima Filho, A. and Brito, A. (2018). A Novel Approach for Brushless DC Motors Characterization in Drones Based on Chaos. *Drones*, 2(2), p.14. doi:10.3390/drones2020014.
- Veselý, V. and Rosinová, D. (2012). Robust PID-PSD Controller Design: BMI Approach. *Asian Journal of Control*, 15(2), pp.469–478. doi:10.1002/asjc.559.

Wachenheim, C., Fan, L. and Zheng, S. (2021). Adoption of unmanned aerial vehicles for pesticide application: Role of social network, resource endowment, and perceptions. *Technology in Society*, 64, p.101470. doi:10.1016/j.techsoc.2020.101470

www.fortunebusinessinsights.com. (n.d.). Agriculture Drone Market Size, Share | Forecast Report [2028]. [online] Available at:

<https://www.fortunebusinessinsights.com/agriculture-drones-market-102589>

