

Thermax123: An educational Excel-based modelling platform for thermo-fluid analyses

M.M. El-Awad

Independent researcher, Khartoum, Sudan

Email: mmelawad09@gmail.com

Abstract

This article describes an educational Excel-based modelling platform for computer-aided analyses and optimisation of thermal-fluid systems and highlights its capabilities for conducting fundamental, design-based and research-oriented analyses. The article initially focuses on the two main components of the platform, which are Excel and the Solver add-in, and gives examples of their use for fundamental and design-oriented analyses from fluid-dynamics and heat-transfer. It then shows how VBA could be used to develop a multi-fluid add-in for fluid properties that extends the capabilities of the Excel-based platform to cover thermodynamic analyses. The article also describes a technique for conducting multi-objective optimisation (MOO) analyses by using the TOPSIS decision-making method and Solver that enables the Excel-based platform to be used for MOO analyses without limiting the number of design variables. Finally, the article demonstrates the capabilities of the platform for research applications by giving an example of a combined ORC-TFC cycle for utilising the low-temperature heat sources such as solar energy, geothermal energy, and industrial waste.

1. Introduction

Without engineering, civilisation does not exist [1]. However, the rapid consumption of the non-renewable energy resources by the construction and operation of large engineering projects, the emissions of greenhouse and ozone-layer depleting gases, and the destruction of the flora and fauna have led to serious environmental problems that now affect the entire globe. Therefore, our future engineers have to be more skilful and creative in their job in order to minimise the adverse impact of their activities and our educational systems has to be more effective in equipping them with the needed theoretical knowledge and analytical problem-solving skills. The view that the traditional curricula and teaching methods cannot cope with the required pace of the learning process is also supported by the fact that the engineering systems themselves are becoming increasingly complicated by introducing new technologies more frequently than before [2]. As a response to the calls from industry, the integration of software-based application with theoretical methods have now become essential in the various engineering study programs [3]. The need to use electronically-based teaching materials during the COVID-19 pandemic also accelerated the use of computer-based demonstration methods to replace or supplement the traditional lab experiments in many engineering curricula [4].

But, how can computers and computer software be used to improve the learning process? According to Niazkari and Afzali [5], a simple answer to this question is that computer-based methods eliminate the tedium and error-prone nature of hand calculations and integrate the students' knowledge of the basic analytical tools with their computer-oriented skills. However, according to Hofmann et al. [4] the full benefit of computer-aided methods can only be realised by introducing the necessary changes in the course contents and teaching methods themselves since the traditional university courses, especially the introductory courses, only go up to the third category of the six categories of the cognitive process which are: remember, understand, apply, analyse, evaluate, and create [6]. According to Hofmann et al. [4], the study goals of modern courses should be to reach the sixth level whereby the students become able to work scientifically on themselves and plan research papers on a given topic. Concerning engineering sciences, they recommended that it is essential to get into independent practice-relevant action in the curriculum as early as possible. There are three levels of undergraduate engineering courses and projects: (1) the fundamental courses, (2) the design-oriented courses, and (3) the student's graduation projects and research assignments. By enabling the students to perform sensitivity analyses

and optimisation analyses at the three levels, computer-aided methods enable the three high-order-thinking (HOT) categories of the cognitive process to be achieved.

Thermo-fluids, which a common name for thermodynamics, fluid-mechanics, and heat-transfer, are fundamental courses for most engineering disciplines including agricultural engineering, chemical engineering, civil engineering, electrical engineering, mechanical engineering, petroleum engineering and others. The two fundamental principles in thermo-fluid analyses are the conservation of mass and the conservation of energy (the first law of thermodynamics). Another common feature of thermo-fluid analyses is the necessity of accounting for the losses that occur in the relevant systems due to friction, heat-transfer, and irreversibility. Since steady-state and uniform systems are usually considered in the three subjects, their fundamental problems mostly involve algebraic equations. However, because of dependence of the physical properties of the fluids involved on the applied pressure and/or temperature, the equations can be nonlinear and, therefore, many thermo-fluid problems require iterative solutions by using computer-aided methods. Computer-aided methods are also needed because certain problems result in systems of algebraic equations, e.g., solving the steady heat-conduction equation by using the finite-difference method. Optimisation analyses are another type of thermo-fluid analyses that need computer-aided methods, e.g., determining the appropriate fraction of steam to be extracted in a regenerative Rankine cycle, determining the economic pipe diameter for a given pump-pipe system, and determining the economic thickness of insulation for a circular duct.

The idea of using spreadsheet software in general, and Microsoft Excel in particular, for teaching of engineering subjects is not new [3,5,7,8]. The reason for this was the widespread availability of Excel on most personal computers without additional cost and its powerful tools for data analysis and visualisation. According to Oke [9], Excel enables simplified program development and debugging, and the use of named ranges and labels enhance the readability of its formulae. The ability to manipulate matrices heightened its popularity and the use of macros for looping and other high-level programming needs also promoted its acceptability. According to Ahmadi-Brooghani [7], using Excel as a modelling platform in the basic engineering subjects improves the learning process, helps the students with their design assignments and final-year projects, and provides future engineers with an effective problem-solving tool for their job. Moreover, the general-purpose software has an important advantage over the dedicated software by allowing the students to develop white-box models for their analyses [8].

Rather than using Excel as a teaching aid for a specific subject or a specific type of problems, the present approach aimed at developing a general Excel-aided modelling platform that can be used to perform fluid-thermal analyses as varied as solving type-2 and type-3 pipe flow problems, solving a two-dimensional heat-transfer problem by using the finite-difference method, performing optimisation design analysis of a pipe-network with multiple loops, analysing a gas-turbine system with intercooling, regeneration, and reheat, analysing the regenerative Rankine cycle with multiple feed-water heaters, analysing a cascade vapour-compression refrigeration (VCR) system with various working fluids, and performing multi-objective optimisation (MOO) and exergoeconomic analyses of gas-turbine cogeneration systems. Therefore, the modelling platform should provide the analytical tools required for conducting iterative solutions and optimisation analyses and for thermodynamic analyses it should also provide the means to determine the thermodynamic properties of various working fluids. The development of this general platform has been achieved by:

- 1) Developing a multi-fluid Excel add-in called Thermax that provides functions for determining the physical properties of the two most commonly used fluids, which are air and water/steam, in addition to 29 ideal gas, 28 synthetic and natural refrigerants, two solutions for vapour-absorption refrigeration (VAR) systems, as well as functions for psychrometric analyses and combustion analyses.
- 2) Developing Excel-aided models for numerous fundamental and design-based analyses of thermal-fluid systems, with proper documentation, so that the models can be used for problem-

based and design-based teaching of thermo-fluid courses such as thermodynamics II, applied thermodynamics, fluid-dynamics II, and computer applications.

- 3) Developing a technique for multi-objective optimisation analyses of fluid-thermal systems by using Excel's Solver with the TOPSIS decision-making method [10]. The effectiveness of this technique, which allows any practical number of design parameters to be considered as design variables, is proven by comparing its solutions with those of the MIDACO solver [11].

The modelling platform has four components which are: (1) Excel with its user interface, (2) the Solver add-in, (3) Thermax for determining fluid properties, and (4) Visual Basic for Applications (VBA) for developing additional user-defined functions. The present article aims to highlight the roles of the four components, give examples of using the platform for fundamental, design-based, and research analyses, and outline the areas for future application and development.

2. Exploiting Excel's own built-in capabilities

Excel is commonly used for statistical analyses and graphical display of data. However, the software developers have equipped it with analytical tools that many students and Excel-users are not aware of or seldom utilise. These include the following three features:

1. The matrix functions that include addition, multiplication, and inversion of matrices
2. Excel's own iterative solver (by invoking the circular-calculation option)
3. The Goal Seek command.

While the matrix functions can be used for solving systems of algebraic equations by applying the matrix-inversion method, the internal iterative solver is more suitable for solving small systems of equations such as those resulting from exergoeconomic analyses of energy-conversion systems. The Goal Seek command is a simple, but very useful tool for "What-If" type of analyses. By using these built-in features, Excel has been used for solving various fundamental problems in fluid-mechanics [12-15] and heat-transfer [16-19]. A good example of the basic fluid-mechanics problems that require iterative solutions is a type-2 or type-3 flow problem and a good example of the basic heat-transfer problems that involve algebraic system of equations is the solution of the two-dimensional conduction heat transfer with heat-generation shown on Figure 1 by using the finite-difference method [16].

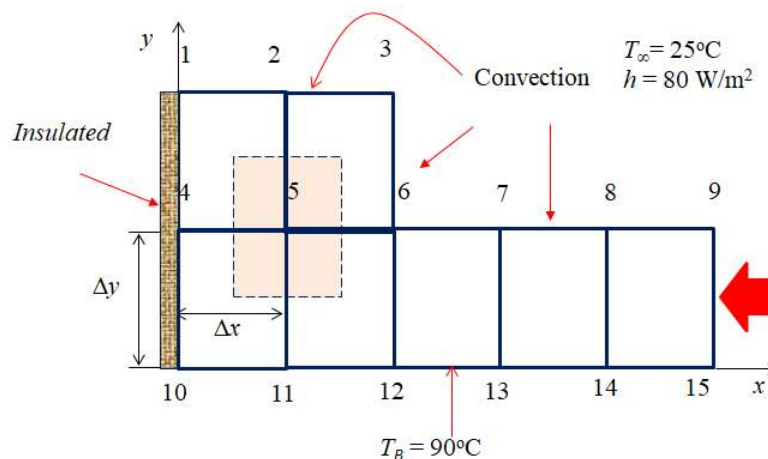

Figure 1. Finite-difference grid for solving the 2D heat-conduction with heat-generation problem [16]

3. Constrained iterative solutions and optimisation analyses by using Solver

The Solver add-in developed by Frontline [20] gives a significant boost to Excel's analytical capabilities. Solver can be used for conducting constrained iterative solutions of various fluid-dynamics and heat-transfer problems with numerous changing variables by using three solution methods, viz., the Simplex LP method, the GRG Nonlinear method, and the Evolutionary method. However, the more

important role for Solver is that it enables Excel to be used for performing single-objective optimisation analyses of fluid systems with practical complexity such as pipe networks [12-15]. Figure 2 shows a pipe network with eight loops described by Brkic [15]. By using its own built-in analytical tools and Solver, Excel can deal with various types of fluid-mechanics and heat-transfer analyses that usually do not involve significant changes in the physical properties of the fluids involved. However, for thermodynamic analyses a means for determining the thermodynamic fluid properties is required. The following section shows how this requirement has been met by developing the Thermax add-in.

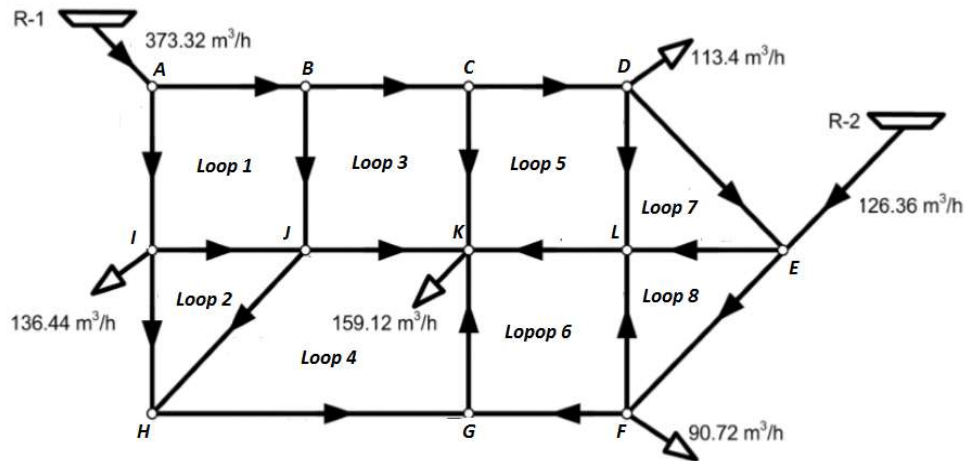

Figure 2. A pipe-network with 8 loops (adapted from Brkic [15])

4. Thermodynamic analyses by using Thermax

There have been many previous attempts to develop special educational Excel add-ins for determining fluid properties, but most of these add-ins had limited options. For example, Goodwin [21] developed **TPX** (Thermodynamic Properties for Excel), that determines the properties of five gases (H_2O , H_2 , O_2 , N_2 , CH_4) and refrigerant R134a. The Mechanical Engineering Department at the University of Alabama developed **Thermotables** that determines the thermodynamic properties of various ideal gases, water and superheated steam, and four refrigerants R134a, R22, R410A, and R407C [22-24]. Oko and Diemuodeke [25] developed an add-in for thermodynamic properties of R152a. Dumka et al. [26] used Excel with **Thermotables** for analysing the influence of bleed pressure on Rankine cycle performance. Jack [27] developed an Excel sheet for computerised calculations of thermo-physical properties of steam and air. Karimi [28] used Excel for thermodynamic analyses of air-standard cycles and combustion processes. The add-in for thermodynamic property calculation with Excel with the largest number of fluids was that developed by Caretto et al. [29] which supports forty substances ten of them are refrigerants. Their add-in identifies the various substances with numbers; air being identified with the number 1 and water with the number 40. The tool can be used to determine individual state points by a graphical user interface (GUI) calculator and can also be used to build models of thermodynamic systems by using the spreadsheet cell formulas and VBA function calls.

They say *the journey of thousand miles begins with a single step*. The journey for developing Thermax began with the development of a VBA function for interpolating the tabulated enthalpy and relative pressure data for air [30]. The interpolation function became the seed for developing property functions for many other fluids and the idea of determining the properties for air alone grew to become that of developing a general multi-fluid add-in [31]. To help the user select the appropriate Thermax function without having to memorise the names of the numerous functions, the functions have been put in eight groups that deal with specific type of working fluids. Table 1 lists the eight groups of functions provided by Thermax. Note that two separate function groups deal with vapour-absorption fluids which are the “LiB” and “NH3” groups. For the “Gas” and “Ref” groups that include numerous fluids, the same function can be used by all fluids in the group by making the fluid’s name as an input to the function.

Table 1. The function groups provided by Thermax

#	Substance(s) of the group	Prefix
1	Ideal gases (29)	Gas...
2	Water and steam	Wat...
3	Refrigerants (28)	Ref...
4	Water lithium-bromide solution	Lib...
5	Ammonia-water solution	Nh3...
6	Psychrometry	Psy
7	Fuels and reacting substances (18)	Chm...
8	Air at atmospheric pressure	Air...

In addition to its fluid property functions, Thermax provides a Newton-Raphson (NR) solver that was originally developed to solve the SRK equation for the specific volume of superheated refrigerants, but later generalised for solving similar non-linear equations such as the Colebrook-White equation.

The name style for Thermax property functions

Figure 3 shows a function in the water group that determines the enthalpy of saturated water at a pressure of 500 kPa and quality of 0.8. As the figure shows, the name of the function consists of the following three parts:

1. The first three letters (1) refer to the function's group, i.e., "Wat" for water/steam.
2. The fourth letter (2), which is followed by an underscore, refers to the function's output property, i.e., "h_" for enthalpy.
3. The letters after the underscore (3) refer to the function's input parameter(s), i.e., "Px" for pressure and quality.

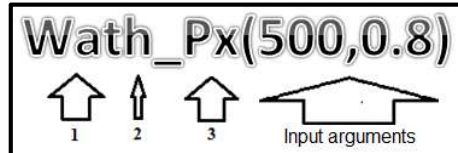

Figure 3. An example function that illustrates the name style for Thermax functions

Using Thermax functions in Excel's formulae

Thermax functions can be used just like Excel's own functions. Figure 4 shows an example Excel sheet which was developed for analysing the regenerative Rankine cycle with a single open feed-water heater as described by Cengel and Boles [32]. Figure 5 reveals the formulae used in the cells to determine the thermodynamic properties of water/steam at all the seven states of the cycle. The specified data of the problem are stored on the left side of the sheet, the calculations of the state properties by using Thermax functions in the middle, and the cycle output parameters on the right side of the sheet. The numerical values shown on Figure 4 can be compared with those given by Cengel and Boles [32].

	A	B	C	D	E	F	G	H	I	J	K
1											
2	P_b	15000	kPa	h_1	191.8174		h_5	3579.44		y_	0.224162
3	T_b	600	oC	v_1	0.00101		s_5	6.733668		x_7	0.811289
4	P_c	10	kPa				s_6s	6.733668			
5	P_i	1200	kPa	h_2s	193.0196		h_6s	2893.458		w_T	1276.394
6	η_p	1		h_2	193.0196		h_6	2893.458		w_P1	0.932721
7	η_T	1		h_3	798.3561		s_6	6.733667		w_P2	15.71153
8				v_3	0.001139		s_7s	6.733667		w_net	1259.75
9				h_4s	814.0676		h_7s	2132.459		Q_in	2765.373
10				h_4	814.0676		h_7	2132.459		η	0.455544
11											

Figure 4. The model results for analysing the regenerative Rankine cycle with a single open feed-water heater

	A	B	C	D	E	F	G	H	I	J	K
1											
2	P_b	15000	kPa	h_1	=wath_Px(P_c,0)	h_5	=Wath_PT(P_b,T_b)	y_	=(h_3-h_2)/(h_6-h_2)		
3	T_b	600	oC	v_1	=watv_Px(P_c,0)	s_5	=Wats_PT(P_b,T_b)	x_7	=(h_7-h_1)/Wathfg_P(P_c)		
4	P_c	10	kPa			s_6s	=s_5				
5	P_i	1200	kPa	h_2s	=h_1+v_1*(P_i-P_c)	h_6s	=Wath_Ps(P_i,s_6s)	w_T	=(h_5-h_6)+(1-y_)*(h_6-h_7)		
6	η_p	1		h_2	=h_1+(h_2s-h_1)/ η_p	h_6	=h_5-(h_5-h_6s)* η_T	w_P1	=(1-y_)*(h_2-h_1)		
7	η_T	1		h_3	=wath_Px(P_i,0)	s_6	=Wats_Ph(P_i,h_6)	w_P2	=(h_4-h_3)		
8				v_3	=watv_Px(P_i,0)	s_7s	=s_6	w_net	=w_T-(w_P1+w_P2)		
9				h_4s	=h_3+v_3*(P_b-P_i)	h_7s	=Wath_Ps(P_c,s_7s)	Q_in	=h_5-h_4		
10				h_4	=h_3+(h_4s-h_3)/ η_p	h_7	=h_6-(h_6-h_7s)* η_T	η	=w_net/Q_in		
11											

Figure 5. The formulae in the Excel sheet for analysing the regenerative Rankine cycle with a single open feed-water heater

A very useful feature of Excel that enables the intended property function to be easily found is the Function Wizard. As Figure 6 shows, the wizard lists all Thermax functions alphabetically starting with those in the “Air” group. Therefore, after being familiar with name style described above, the user can easily select the required property function. Of course, *practice makes perfect*.

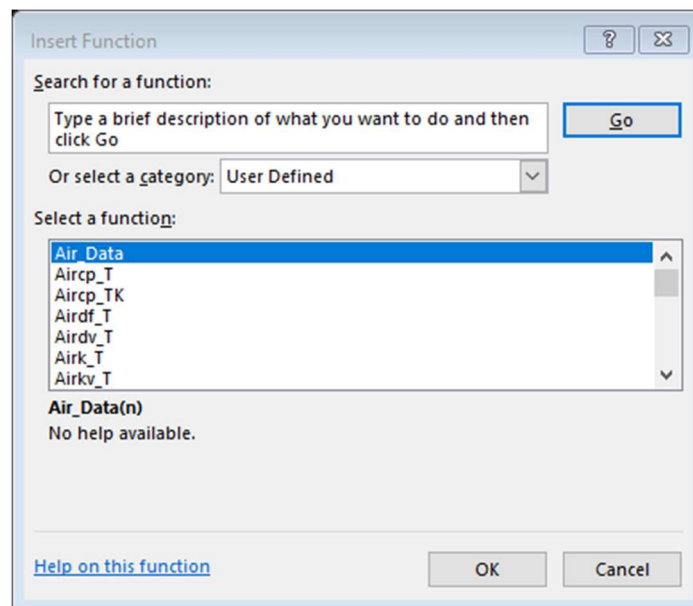

Figure 6. Finding a Thermax function by using the Function Wizard

Verification of Thermax property functions in the refrigerants group

Thermax property functions for ideal gases, superheated steam, the two VAR solutions, and the functions for psychrometric and combustion analyses use mathematical formulae obtained from standard text books or the open literature. For example, properties of superheated steam are obtained by using the formulae provided by Irvine and Liley [33]. The “Air” group functions interpolate the tabulated data given by Cengel and Ghajar [34] and the functions for saturated liquid and saturated vapour for water and all refrigerants interpolate the data provided by ASHRAE [35]. However, the functions that determine the enthalpy and entropy of superheated refrigerants use ideal-gas equations in which the specific heat is determined at an adjusted pressure by multiplying the actual pressure by a “compressibility factor” for which an average value of 0.5 is adopted [36]. The accuracy of these functions was evaluated by comparing their estimations with published data that used other software like EES (Engineering Equation Solver) [37] and REFPROP [38]. Figure 7 and Figure 8 that compare the results of analysing a cascade VCR system with R507A and R23 with those obtained by Parekh and Tailor [39] prove the accuracy of these functions. The accuracy of these functions was also verified for a number of other synthetic and natural refrigerants [31,36,40,41].

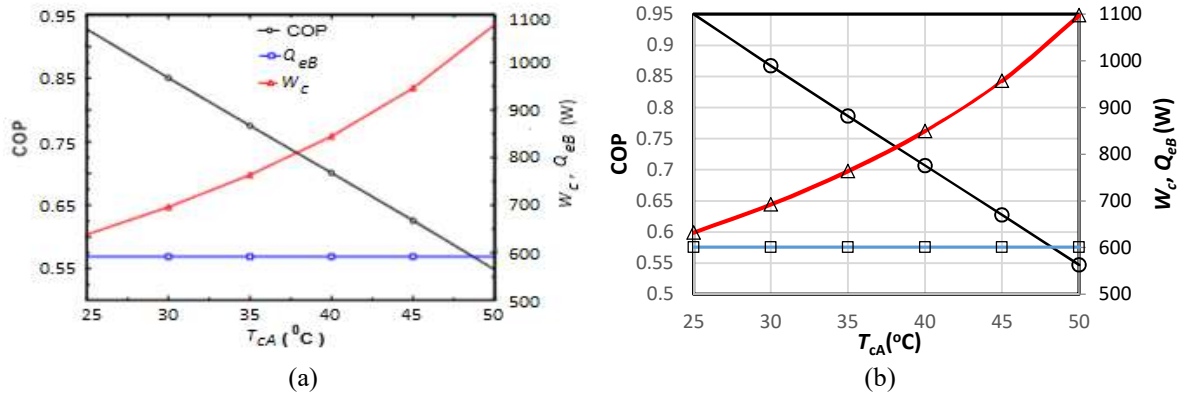

Figure 7. Effect of the high-temperature stage condensing temperature on COP, Q_{eB} and W_c

(a) adapted from Parekh and Tailor [39], (b) present results

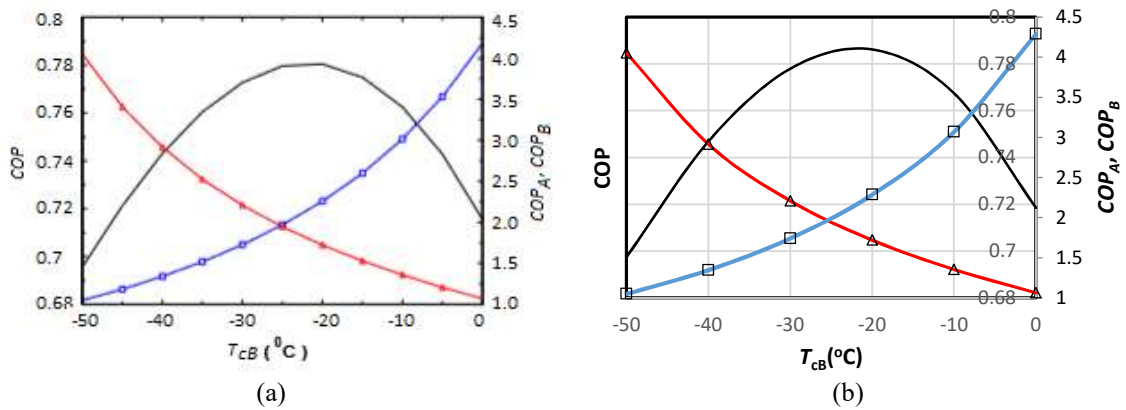

Figure 8. Effect of the low-temperature stage condensing temperature on COP, COP_A , and COP_B :

(a) adapted from Parekh and Tailor [39], (b) present results

5. A Solver-TOPSIS technique for multi-objective optimisation analyses

The concerns about the damage to the environment and the climate changes caused by use of fossil-fuels for electricity generation call for replacing the conventional power plants by the more efficient cogeneration and tri-generation systems and hybrid and integrated systems. In addition to the technical and economic factors, design analyses of such systems have to consider the environmental, safety, and social factors. To find acceptable trade-offs between these usually conflicting objectives the usual single-objective optimisation (SOO) methods have to be replaced by MOO methods. While Excel's Solver can easily be used to conduct SOO analyses with practically unlimited number of design variables, it cannot deal with MOO analyses in its present form. The free version of the MIDACO solver [10] can be used to conduct MOO analyses involving up to four changing variables. Therefore, a solver that allows the Excel-based platform to include more than four design variables is needed. Considering the difficulty and time required to develop a multi-objective solver [42], the TOPSIS decision-making method [10] is utilised in an active for adjusting the base design variables so as to maximise the value of the factor C_i that measures the relative closeness of the design to the ideal design. The maximisation of C_i , which is a SOO analysis, could be performed by using either the Evolutionary method or the GRG Nonlinear method of Solver. The results obtained by this technique for various power generation and refrigeration systems show that the technique worked well with both methods [43].

Figure 9 shows a schematic diagram of a cogeneration system with an air preheater given by Bejan et al. [44]. Figure 10 compares the values of thermal efficiency, exergetic efficiency, total cost rate, and CO_2 emissions of the system as determined by three SOO solutions and by the Solver-TOPSIS technique to maximise the exergetic efficiency while minimising both the total cost rate and CO_2 emissions (3E) by adjusting six design variables of the base design. Figure 10 shows that the solution

obtained by using the Solver-TOPSIS technique gave the highest values of the thermal and exergetic efficiencies and the lowest values of the total cost rate and CO₂ emissions.

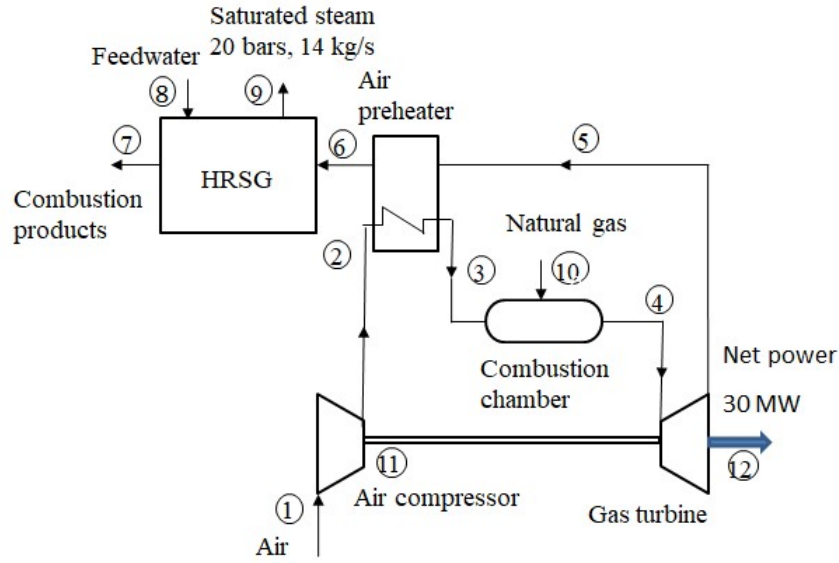

Figure 9. Cogeneration system (adapted from Bejan et al [44])

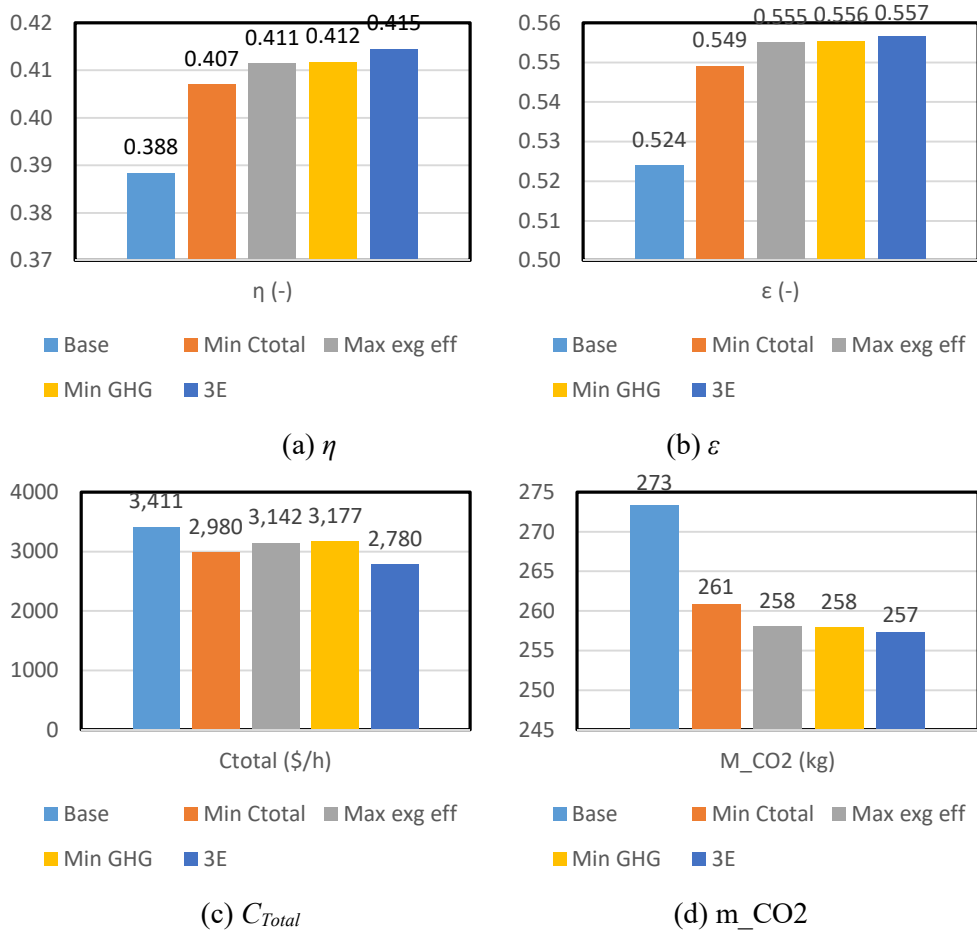

Figure 10. Comparison of the Solver-TOPSIS optimised solution and Solver's three single-objective solutions to the base-design values

6. Research and Innovation

The main motive for developing the present Excel-based modelling platform is to encourage students' research and innovation by supporting an appreciable number of working fluids and by enabling SOO as well as MOO analyses. In this respect, the platform is particularly useful for the students and institutions in developing countries and independent researchers who do not have access to commercial software. The potential of the platform for research and innovation related to energy-conversion systems is illustrated by the case of the combined organic Rankine cycle (ORC) with a trilateral flash cycle (TFC) shown on Figure 11. Although both cycles have been analysed extensively, the two cycles are usually compared as alternative cycles and not as a combined cycle.

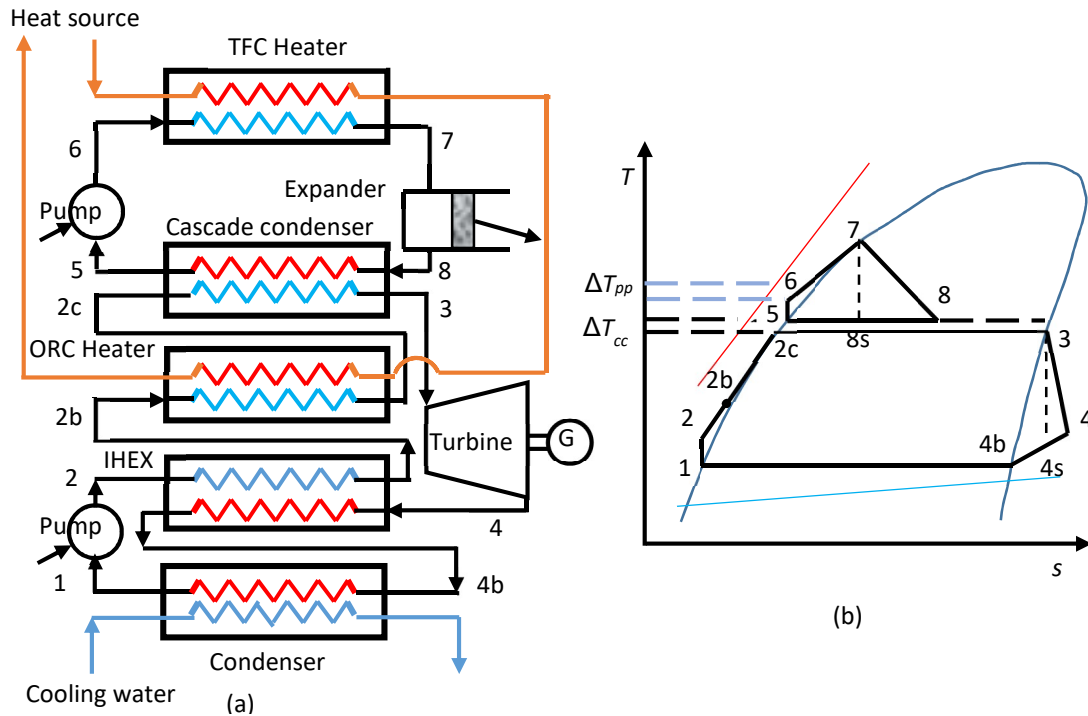

Figure 11. Schematic and T - s diagrams of the combined ORC-TFC cycle

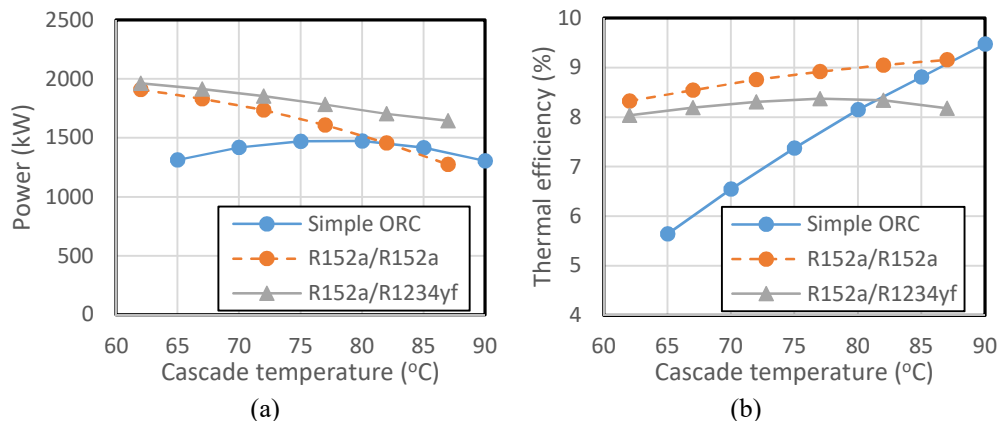

Figure 12. Comparison of (a) the power and (b) thermal efficiency of the combined cycle with R1234yf/R152a with those with R152a/R152a and the simple ORC

The thermodynamic performance of the combined ORC-TFC cycle was compared to that of the simple ORC cycle over a range of cascade temperatures by using R152a and R1234yf as working fluids [40]. Figure 12 shows that, below a cascade temperature of 80°C, both the power and thermal efficiency of the combined cycle with both R152a/R152a and R152a/R1234yf are higher than those of the simple ORC with R152a. A tri-objective thermodynamic analysis of the combined cycle is given in [41].

7. Concluding remarks

In order to be useful as teaching material at different study levels, the development of Thermax and the numerous models developed for thermo-fluid analyses has been documented by three books with distinct focus. The first book describes the Excel-based modelling platform in more details and applies it for various types of basic computer-aided analyses and optimisation of thermal-fluid systems using conventional methods. The book mainly deals with fluid-mechanics and heat-transfer analyses by using Excel's iterative tools and the Solver add-in. Chapter 2 of the book is devoted to Excel and its built-in features and Chapter 3 to Solver, VBA, and Thermax. The following chapters of the book deal with basic iterative solutions and optimisation analyses, solving steady and transient heat-conduction problems by using the finite-difference method, hydraulic analyses of multi-pipe systems, pump-pipe systems, and pipe networks as well as design analyses of fluid-thermal systems, and optimisation analyses of pipelines and pipe-networks. The book can be used as the main reference for an intermediate course on computer applications or to provide supporting material for existing fluid-mechanics and heat-transfer courses.

The second book focusses on thermodynamic analyses and describes Thermax in more details. After giving detailed descriptions of the different add-in function groups, the book gives examples of using it for basic analyses usually covered in standard thermodynamic courses including power-generation, refrigeration, psychrometry and air-conditioning, and combustion analyses. The book gives examples that are not usually covered in standard textbook including the organic Rankine cycle (ORC) with different working fluids and the VAR cycle and introduces the conventional energy-based thermoeconomic analyses of energy-conversion systems. Finally, it presents a thermodynamic evaluation of an innovative combined ORC-TFC cycle. This book can be used for supporting the standard thermodynamics courses: Thermodynamics I, Thermodynamics II and Applied Thermodynamics. The third book focuses on MOO and exergoeconomic analyses of energy-conversion systems. It also introduces the Solver-TOPSIS technique and applies it for conducting a MOO analysis of a regenerative gas-turbine and developing an Excel-aided procedure for MOO and exergoeconomic analyses of gas-turbine air-bottoming and co-generation systems. The final chapter of the book shows how the Excel-based modelling platform can be used for conducting advanced exergoeconomic analyses by considering the simple gas-turbine. The book can be used for an advanced undergraduate course and to support relevant post-graduate courses on energy-conversion systems.

The application and research capabilities of the Excel-based platform can also be enhanced by using other property add-ins that have been developed for research and industrial applications such as REFPROP [38], CoolProp [45] and XProps [46]. In addition to developing Excel-aided models for the usual thermo-fluid analyses, the macros and animation tools provided by Excel's Developer tab can be utilised with the help of Thermax functions for the development of pseudo-physical models of various fluid-thermal systems such as I.C. engines [47].

Acknowledgements

The author benefitted greatly from the efforts of the Mechanical Engineering Department at the University of Alabama who made the various add-ins developed for their "Excel-for-ME" project available on the internet. Most of the material needed for the first two books was prepared during the author's tenure at the College of Applied Sciences (CAS) at Sohar, Oman. The author is truly indebted to CAS for the extended appointment. The author worked on the last book as an independent researcher during a difficult time in Sudan and he is grateful for the Government of Sudan and her Engineers for their unfailing support without which this article wouldn't have seen the light.

References

- [1] A. Bejan, *Without Engineering, Civilization Does Not Exist*, 1st Edition, 2018.

- [2] M. M. Rahman, U. S. Ferdousi, T. Hasan and T. Sharmin (2022), Challenges in Engineering Education: A Review, Proceedings of the 5th International Conference on Industrial & Mechanical Engineering and Operations Management, Dhaka, Bangladesh, December 26-27, 2022
- [3] P. Saha (2022) Effectiveness of in-class Excel-based active learning activities for transportation engineering courses. *Front. Educ.* 7:879174. doi: 10.3389/feduc.2022.879174
- [4] M. Hofmann, F. Witte, M. Fritz, J. Freißmann, I. Tuschy, G. Tsatsaronis (2023), Free and Open-Source Teaching: Understanding Exergy using Thermal Engineering Systems in Python (TESPy), Proceedings of ECOS 2023 - the 36th International Conference on Efficiency, Cost, Optimization, Simulation and Environmental Impact of Energy Systems 25-30 June, 2023, Las Palmas de Dran Canaria, Spain
- [5] M. Niazkar, and S.H. Afzali. (2015) Application of Excel Spreadsheet in Engineering Education. First International & Fourth National Conference on Engineering Education, Shiraz, 10-12 November 2015.
- [6] L. W. Anderson and D. R. Krathwohl, eds. (2001), *A Taxonomy for Learning, Teaching, and Assessing: A Revision of Bloom's Taxonomy of Educational Objectives*. New York: Longman, 2001.
- [7] Z. Ahmadi-Brooghani (2006), Using Spreadsheets as a Computational Tool in Teaching Mechanical Engineering, Proceedings of the 10th WSEAS International Conference on computers, Vouliagmeni, Athens, Greece, July 1315, 2006, 305-310
- [8] S.T. Simaremare, L. Atika, R. Siregar (2024), Effectivity of the Microsoft Excel Application on Student Understanding in Statistics Courses, *Indonesian Journal of Education and Social Humanities* Volume 1 (2) 9 – 19 June 2024, ISSN: 3047-9843, Open Access at: <https://journal.mgedukasia.or.id/index.php/ijesh>
- [9] S. A. Oke (2004), Spreadsheet Applications in Engineering Education: A Review, *Int. J. Engng Ed.* Vol. 20, No. 6, pp. 893-901, 2004,
- [10] S. Diyaley, P. Shilal, I. Shivakoti, R.K. Ghadai and K. Kalita, (2017), PSI and TOPSIS Based Selection of Process Parameters in WEDM, *Periodica Polytechnica. Engineering. Mechanical Engineering*, vol. 61, pp. 255
- [11] M. Schlueter, S. Erb, M. Gerds, S. Kemble, J.J. Rueckmann (2013). MIDACO on MINLP Space Applications. *Advances in Space Research.* 51 (7): 1116–1131
- [12] A. N. El-Bahrawy (1997), A spreadsheet teaching tool for analysis of pipe networks, *Engineering Journal of University of Qatar*, vol. 10, 1997, p. 33 – 50, the internet: https://www.researchgate.net/profile/Aly_El-Bahrawy/contributions
- [13] A.M. Elfeki, (2013), Pipe network analysis example with Excel Solver, Researchgate, available at: https://www.researchgate.net/publication/258051650_Pipe_Network_Analysis_Example_with_Excel_Solver
- [14] A. Rivas, T. Gómez-Acebo, and J. C. Ramos (2006). The application of spreadsheets to the analysis and optimization of systems and processes in the teaching of hydraulic and thermal engineering, *Computer Applications in Engineering Education*, Vol. 14, Issue 4, 2006, pp. 256-268.
- [15] D. Brkic (2016), Spreadsheet-Based Pipe Networks Analysis for Teaching and Learning Purpose, *Spreadsheets in Education (eJSiE)*: Vol. 9: Iss. 2, Article 4, 2016. Available at: <http://epublications.bond.edu.au/ejsie/vol9/iss2/4>
- [16] E. M. A. Mokheimer and M. A. Antar (2000), On the use of spreadsheets in heat conduction analysis, *International Journal of Mechanical Engineering Education* Vol 28 No 2, April 2000
- [17] R. Edwards and M. Lobaugh (2014), Using Excel to Implement the Finite Difference Method for 2-D Heat Transfer in a Mechanical Engineering Technology Course, 121st ASEE Annual Conference and Exposition, Indianapolis, June 15-18, 2014
- [18] P. Anthony (2016), Solutions of One Dimensional Heat Equation Using Excel Worksheet , *Imperial Journal of Interdisciplinary Research (IJIR)* Vol-2, Issue-8, 2016 ISSN: 2454-1362, available at: <http://www.onlinejournal.in>
- [19] A. Karimi (2009), A compilation of examples for using Excel in solving heat transfer problems, American Society for Engineering Education Conference, AC 2009-2284, University of Texas, San Antonio, 2009
- [20] FrontlineSolvers, internet: <http://www.Solver.com/>
- [21] D. G. Goodwin, TPX: thermodynamic properties for Excel, http://termodinamicaparaiaq.blogspot.com/p/tpx_12.html
- [22] The University of Alabama, Mechanical Engineering, Excel for Mechanical Engineering project, Internet: <http://www.me.ua.edu/excelinme/index.htm>
- [23] J. Huguet, K. Woodbury, R. Taylor (2008), Development of Excel add-in modules for use in thermodynamics curriculum: steam and ideal gas properties, American Society for Engineering Education, 2008, AC 2008-1751.

- [24] K. Mahan, J. Huguet, K. Woodbury, R. Taylor (2009), Excel in ME: Extending and refining ubiquitous software tools, American Society for Engineering Education, 2009, AC 2009-2295.
- [25] C.O.C. Oko and E.O. Diemuodeke (2013), MS Excel spreadsheet add-in for thermodynamic properties and process simulation of R152a, *Energy Science and Technology*, Vol. 5, No. 2, 2013, pp. 63-69.
- [26] P. Dumka, R. Chauhan, K. Rana, K. Gajula, A. Mishra, A. K. Srivastava. D.R. Mishra (2024), Using Spreadsheets for Analysing the Influence of Bleed Pressure on Rankine Cycle Performance, the electronic Journal of Spreadsheets in Education, March 06, 2024
- [27] T. K. Jack (2012). Computerised calculations of thermo-physical steam and air properties, *Int. J. Pure Appl. Sci. Technol.*, 9(2) (2012), pp. 84-93 (*Available online at http://ijopaasat.in/yahoo_site_admin/assets/docs/3_IJPAST-276-V9N2.139104407.pdf*)
- [28] A. Karimi (2009), Using Excel for the thermodynamic analyses of air-standard cycles and combustion processes, ASME 2009 Lake Buena Vista, Florida, USA.
- [29] L. Caretto, D. McDaniel, T. Mincer (2005). Spreadsheet calculations of thermodynamic properties, Proceedings of the 2005 American Society for Engineering Education Annual Conference & Exposition, American Society for Engineering Education, 2005.
- [30] M.M. El-Awad, A.M. Elseory (2012), Excel as a Teaching Aid for Thermodynamics, Proc. the International Conference on Automotive, Mechanical and Materials Engineering (ICAMME'2012), May 19-20, 2012 in Penang (Malaysia).
- [31] M.M. El-Awad (2019), A Multi-Subject Excel Add-In for Fluid Properties and its Use for analysing Cascade and Multi-Stage Compression Refrigeration Cycles, The Electronic Journal of Spreadsheets in Education (eJSiE) Vol. 12, Issue 1, April 18, 2019
- [32] Y.A. Cengel, and M.A. Boles, *Thermodynamics an Engineering Approach*, McGraw-Hill, 7th Edition, 2007.
- [33] T.F. Irvine Jr. and P.E. Liley (1984). Steam and gas tables with computer equations. Orlando, (FL): Academic Press, 1984.
- [34] Y. A. Cengel and A. J. Ghajar, *Heat and Mass Transfer: Fundamentals and Applications*. 4th edition, McGraw-Hill, 2011
- [35] ASHRAE Handbook–Refrigeration, 2017, American Society of Heating, Refrigerating and Air-Conditioning Engineers, Inc., (SI Edition).
- [36] M.M. El-Awad, M.S. Al Nabhani, K.S. Al Hinai, A. Younis, (2019). Development and Validation of an Excel Add-In for Determining the Properties of Various Refrigerants, Proceedings of First National Conference on Recent Trends in Applied Science, Engineering and Technology (CASET 2K19), Ipri College of Technology, June 11, 2019.
- [37] F-Chart Software, <https://www.fchartsoftware.com/ees/>
- [38] E.W. Lemmon, M.L. Huber, M.O. McLinden (2007), *NIST Reference Fluid Thermodynamic and Transport Properties— REFPROP* Version 8.0, User's Guide, National Institute of Standards and Technology, Physical and Chemical Properties Division, Boulder, Colorado 80305, 2007.
- [39] A. D. Parekh and P. R. Tailor (2011), Thermodynamic Analysis of R507A-R23 Cascade Refrigeration System, World Academy of Science, Engineering and Technology International Journal of Mechanical and Mechatronics Engineering Vol:5, No:9, 2011
- [40] M.M. El-Awad (2024), Thermodynamic Evaluation of a Combined ORC-TFC Cycle for Low-Temperature Power Generation by using Microsoft Excel, Engineering Archive Preprint <https://engrxiv.org/preprint/view/3869>
- [41] M.M. El-Awad (2024), Tri-Objective Optimisation of a Combined ORC-TFC Cycle for Low-Temperature Power Generation, Engineering Archive Preprint <https://engrxiv.org/preprint/view/3892>
- [42] T. Balabanov (2021), Solving multi-objective problems by means of single objective solver, Problems of engineering cybernetics and robotics • Vol. 76, 2021, pp. 63-70, <https://doi.org/10.7546/PECR.76.21.05>
- [43] M.M. El-Awad (2024), Multi-objective optimisation of VCR systems by applying TOPSIS to the single-objective solutions obtained with Excel Solver, paper accepted by the electronic Journal of Spreadsheets in Education (eJSiE), April 2024, <https://engrxiv.org/preprint/view/3667>
- [44] A. Bejan, G. Tsatsaronis, M. Moran, *Thermal Design & Optimisation*, John Wiley & Sons, 1996.
- [45] I. Bell, CoolProp. <https://sourceforge.net/projects/coolprop/files/CoolProp/>
- [46] Optimized Thermal Systems, XProps, A Quick and easy way to call refrigerant properties, <http://optimizedthermalsystems.com/index.php/products/xprops>
- [47] M.M. El-Awad, Developing Simulation Models with Excel for Cooperative Project-Based Learning of I.C. Engines, Academia Preprint, https://www.academia.edu/82524318/Developing_Simulation_Models_with_Excel_for_Cooperative_Project_Based_Learning_of_I_C_Engines