

Mechanisms for Dealing With the Unexpected in Small-Scale Contracting Using Smart Contracts

Mathew B. Fukuzawa¹, Michael G. Kay², Brandon M. McConnell^{2,3}, Kristin Thoney-Barletta⁴, and Donald P. Warsing^{3,5}

¹Department of Mathematical Sciences, United States Military Academy, West Point, NY

²Department of Industrial & Systems Engineering, NC State University, Raleigh, NC

³Center for Additive Manufacturing and Logistics, NC State University, Raleigh, NC

⁴Department of Textile and Apparel, Technology & Management, NC State University, Raleigh, NC

⁵Department of Business Management, NC State University, Raleigh, NC

Abstract

Purpose - Demonstrate proof-of-concept for an expanded blockchain smart contract based small-scale contracting process that includes an internally managed arbitration service to manage disputes.

Design/Methodology/Approach - Using Ethereum smart contracts, we model a small-scale general contracting scenario with disruptions. Execution is demonstrated with the Remix Integrated Development Environment (IDE).

Findings - We show the feasibility of managing general contracting disputes with an internal arbitration service, completely encompassed within blockchain smart contracts.

Originality/value - This research continues an original effort to model the small-scale general contracting scenario on a blockchain network.

Research limitations/implications - Further work is required to expand the scope of dispute management and account for additional external factors. Also, full-scale decentralized application is not explored here.

Practical implications - This process expands the scope of current practices and tools, such as Angi, in a decentralized manner with blockchain.

Social Implications - Full-scale adoption at the small scale is likely difficult due to disbelief in technology, cost, and resistance to change.

Keywords: blockchain, smart contract, arbitration, letter of credit, general contracting, contractor, contract.

Paper type: Research paper.

1 Introduction

Homeownership is one of the biggest decisions Americans must make in their adult lives. For most, it is the largest purchase in a lifetime. As of 2022, the Federal Reserve estimates that roughly 66 percent of adults in the US own a home (Bieber, 2023b, Federal Reserve, 2022). Virtually all residents, whether owning or renting, face issues that require maintenance or construction of property. These issues can range in scope from the very simple (e.g., changing a light bulb) to the very complex (e.g., building an addition). Regardless of the type of project, people have options when dealing with the issue. Some may choose to ignore the issue, others may attempt to handle it themselves, and many others may choose to hire a professional such as a general contractor (CTR), to perform the work.

Trust is a central issue when a client (CLT) needs to hire a CTR to perform a small-scale job akin to a homeowner and local general contractor. Neither party has a history of interaction (assumed), and therefore there is some level of risk in entering this relationship. A CTR might fear that they will not receive payment, while a CLT worries that the job will not be completed to a satisfactory quality. Fukuzawa et al. (2024) examine this scenario using a letter-of-credit style framework built on blockchain smart contracts. The entire process is handled with three primary smart contracts, which document job requirements, receive payments, and update job progress. Just like with the letter of credit, payment security is established through a commitment of funds. However, the authors operate under the assumptions of total honesty and perfect conditions. Parties have no intentions to deceive one another, and the job is completed as planned, on schedule, and with acceptable quality. Not only are these somewhat unrealistic conditions but there is perhaps some sense of expected failure. CLTs almost expect some sort of issue to arise with CTR work which feeds the distrust between parties (Alair Homes, 2019). Fukuzawa et al. (2024) omit the realistic cases where a job does not progress as expected.

When it comes to finding a CTR to perform some work, a CLT may elect to research the best options available. This includes everything from word-of-mouth to internet searches to home improvement mobile applications (apps). Current trends include the use of mobile apps such as Angi or Thumbtack, which largely serve as connection points to find the appropriate CTR. Angi does offer some expanded services, such as the ability to pay a CTR through the app (Angi, 2024). However, certain aspects of the general contracting process are ignored by Angi. Angi does not require parties to communicate through their app, and in fact, all traditional contractual negotiations are handled outside of the app. Furthermore, when there are issues or disagreements that prevent job completion, Angi only offers very limited assistance. Angi outsources all major disputes to the American Arbitration Association (AAA) as part of a binding arbitration process (Angi, 2021). As we discuss in Section 2, there are potential biases involved with binding arbitration.

However, arbitration is not the only means by which parties can resolve disputes. No matter the type of negotiation or transaction, there is always a risk that one side does not honor their commitment. In these instances, parties may simply choose to wait for the process to naturally evolve. For stubborn participants, waiting is not ideal. The use of force or threats may also drive action. Even the threat of involving law enforcement or legal proceedings, for example, is sometimes enough to enable progress. However, violence and aggressive behavior are likely to lead to personal injury or property damage and may even lead to arrest. More modern techniques include the use of media to crowdsource assistance, especially with social media. The success rates with this approach are largely unknown. There are also administrative actions available depending on the industry. With a general CTR, states can hear complaints at the licensing board and occasionally levy administrative penalties against a CTR. However, using North Carolina as an example, the board only hears complaints in the case where a project is valued at or above \$40,000 (NCLBGC, 2023). In the opposite direction, a CTR can request a lien on a CLT's property until payment receipt. Of course, parties are always free to pursue litigation, but the financial and temporal costs often make this untenable. There are other legal considerations that complicate this matter, again using North Carolina as an example. Due to scheduling backlogs, many counties mandate that all civil disputes involving financial amounts less than \$25,000 must go to arbitration (NCJB, 2023a). For those high-value amounts that do pass the screening for litigation, courts do not have the authority to order the arrest of a defendant, nor can they enforce wage garnishment to recoup funds (NCJB, 2023b). Thus, parties at the small scale (especially a CLT) have limited means to resolve disputes and enforce compliance. While litigation may offer the best chance for success, it is often inaccessible due to the associated costs. This gap leads to the natural question: *How can we improve the small-scale general contracting scenario using blockchain smart contracts to offer more accessible means*

of dispute resolution?

Dispute resolution is a key component of any partnership or agreement. Parties want an understanding that if issues arise, there is a method to resolve them. E-commerce is one area where dispute resolution tools, primarily online systems, are advancing (Kleros, 2024, Zhuk, 2023). However, there is no analogous tool for the small-scale general contracting scenario. The home improvement apps like Angi and Thumbtack offer some limited protection in the form of a damage guarantee or refund (Angi, 2024, Thumbtack, 2024), but some of these services require a membership fee.

Using the work of Fukuzawa et al. (2024) as a starting point, we advance the design to include options for dispute resolution. Their base design is an all-encompassing blockchain-based process for small-scale contracting which captures the major elements of the interaction. However, the process is assumed under perfect conditions with no requirement for third-party intervention. This research tackles those limitations with an internally available resolution method. Thus, we can potentially eliminate the need for parties to pursue some of the costly options discussed previously. While we do not prevent anyone from seeking litigation, a blockchain-based resolution tool can help save on legal costs and provide quicker settlements (Cianci et al., 2024, Ustun and Yuce, 2022). Given that research on large-scale dispute resolution is ongoing, namely with construction (Cheung et al., 2004, Ojiako et al., 2018, Saygili et al., 2022), it seems warranted that smaller-scale efforts should also be advanced. This paper investigates a blockchain-based method built on Ethereum for involving a third-party (3P) arbitrator (ARB) in the small-scale general contracting process when things break down. We extend the work of Fukuzawa et al. (2024) with two example scenarios to demonstrate proof-of-concept for an arbitration service that is managed locally and provides parties with confidence in a fair system. We also further enhance this previous work with an infusion of simple project management concepts in the job planning stages of the process to help provide structure and justification. In consideration of the preceding discussion, we propose the following questions:

RQ1: How do we incorporate a 3P ARB into the base design process?

RQ2: How do we foster ARB neutrality? How do we reduce perceived bias and unfairness?

RQ3: How can we incorporate a time and task-based project at the small scale with a 3P ARB?

Following this introduction, some background on arbitration is provided to help understand the negative perceptions and stigmas surrounding its mandatory usage. Afterward, a literature review gives insight into arbitration research as well as methods for dispute resolution. Then, a demonstration of the smart contract-based general contracting process with internal dispute resolution is offered through the use of two example scenarios. Finally, suggestions for future study are presented.

2 Background

Arbitration is one form of dispute resolution, commonly viewed as a quicker and cheaper alternative to litigation. Most consumer agreements stipulate *binding* arbitration, whereby an ARB’s ruling is final and cannot be overturned in court (JAMS, 2023). In this manner, arbitration is typically outsourced privately to a national agency such as the American Arbitration Association (AAA) or Judicial Arbitration and Mediation Services, Inc. (JAMS). Private arbitration fees vary widely based on the case complexity and ARB experience. Thus, in addition to any administrative fees paid to these agencies, individual ARBs also levy a professional fee on parties. These fees can range from several hundred to several thousand dollars, typically billed hourly or daily (AAA, 2023, University of Missouri, 2015). Court-ordered arbitration is slightly more predictable, with fee amounts publicly available. Regardless of the type, arbitration processes are starting to resemble legal proceedings due to the presence (and cost) of counsel, which tends to lengthen the discovery process (Bannon et al., 2021, Fotohabadi, 2023). For a deeper look at arbitration types and fees, as well as court costs using North Carolina as an example, the reader should consult Fukuzawa (2024).

Some data suggests that consumer-led complaints are rarely successful, while companies benefit an overwhelming majority of the time (Shierholz, 2017a). Some of these figures are affected by seemingly low consumer usage rates of the arbitration process (CFPB, 2015, Ghodoosi and Sharif, 2021). The numbers only tell part of the story, however, as studies indicate that people prefer litigation over arbitration due to the perception of justice; this is referred to as the arbitration effect (Ghodoosi and Sharif, 2023). Private

arbitration is such a secretive process that little is known about the hearing process or the results, which are not published (Liu, 2023). Large companies find value in arbitration not only because of the secrecy, but financial damages tend to be less than court settlements, and corporate accountability for damaging issues is often overlooked (Hiltzik, 2017, Koren, 2017). Many ARBs used by AAA and JAMS are former judges and lawyers, who are incentivized to favor large companies because of the economic gain from repeated usage (Corkery and Colvin, 2016). Furthermore, recent news stories bring attention to the perceived bias and unfairness associated with mandatory usage, especially at the corporate level.

Wells Fargo Wells Fargo employees opened millions of fraudulent customer accounts from 2009 to 2017, citing corporate pressure to increase sales (Cowley, 2017). Buried deep within the Wells Fargo membership contract was a mandatory arbitration clause that also prevented the banding together of members from initiating class action lawsuits. Yet only 250 customers filed for arbitration (Level Playing Field, 2017). While parties are typically allowed legal representation, many lawyers refused to represent customers due to the limited potential financial damages (Corkery and Colvin, 2016), no doubt a result of the ban on class action cases. Most astonishingly, Wells Fargo gained more money via the arbitration process than it was forced to payout; the average customer paid \$11,000 as a result of arbitration (EPI, 2017, Shierholz, 2017b).

Cigna The Federal Arbitration Act (FAA) of 1925 allows employers to include mandatory arbitration clauses in employee contracts to resolve disputes (Stone and Colvin, 2015). Although attempts to change this law have been initiated, support is lacking for change. Glenda Perez, a former employee of healthcare group Cigna from 2013 to 2017, was fired after making racial discrimination claims (Bland and Ocamb, 2021). As part of her contract, Mrs. Perez was forced to use arbitration. Unable to find legal representation willing to undertake a civil rights case, Mrs. Perez faced Cigna and their team of lawyers alone (Hayes, 2022). The case was ultimately dismissed without hearing, but Perez’s husband would later unearth a photograph showing a personal relationship between the lead arbitrator and Cigna’s lead counsel (Hayes, 2022). Perez’s husband also worked for Cigna, and he was subsequently fired after asking a court to consider arbitrator bias (Bland and Ocamb, 2021).

3 Literature Review

The literature review is largely concerned with dispute resolution and 3P incorporation. We highlight the ongoing research into arbitration, both traditionally and using blockchain methods. The review concludes with recent efforts to incorporate project management with blockchain.

3.1 Arbitration

Research on arbitration is decades old; nevertheless, the topic remains controversial to this day. Critics pay particular attention to mandatory arbitration, a contractual clause allowed by the FAA and typically accompanied with a ban on class action lawsuits. Some argue that forced arbitration favors large corporations, who are often repeat customers and may gain an advantage. On the contrary, supporters argue that in the absence of forced arbitration, plaintiffs would flood the legal system with small claims. While the limited arbitration data is unclear about bias, the recent media spotlight on arbitration tends to paint a negative picture of the process.

In part due to consumer outcries over arbitration, the Dodd-Frank Wall Street Reform and Consumer Protection Act of 2010 directs the Consumer Financial Protection Bureau (CFPB) to report on arbitration and its connection with consumer products and services (CFPB, 2015). The CFPB report, though, is not necessarily supportive of arbitration critics. For example, CFPB finds that with credit card contracts, only 16% of issuers have arbitration clauses (CFPB, 2015). Interestingly, CFPB suggests that due to the low number of cases involving claim amounts less than \$1,000, arbitration is not an effective dispute resolution technique for consumers (CFPB, 2015). However, the report overlooks the hypothesis that many small-value claims are settled without arbitration (Johnston and Zywicki, 2016). Johnston and Zywicki (2016) assert that federal lawmakers view arbitration as quicker, cheaper, and simpler than litigation, with Congress arguing that class action lawsuits can be harmful to the economy. Furthermore, while the report sheds some light on

previously hidden AAA data, it fails to reveal any evidence that forced arbitration is harmful to consumers (Johnston and Zywicki, 2016). Stipanowich (1988) discusses a survey of attorneys by the American Bar Association, in which arbitration is generally preferred over litigation, but there are conflicting viewpoints on arbitrator selection, speed, and efficiency.

In their empirical study of more than 40,000 arbitration cases from 2010 to 2016, Chandrasekher and Horton (2019) deduce that win rates are influenced by the presence of counsel with arbitration experience. Furthermore, self-represented plaintiffs tend to have lower win rates, perhaps because they rarely file claims. While percentages show a dramatic difference in plaintiff win rates in arbitration versus court, there are potentially confounding variables that limit inference power. Besides success rates, the authors also find that arbitration outcomes tend to favor repeat users on both sides of the table (Chandrasekher and Horton, 2019). This phenomenon is sometimes referred to as the repeat-player effect, where participants with arbitration experience tend to achieve more success likely because of a strategic advantage gained from knowledge of the process (Bingham, 1997). Other empirical evidence suggests that when cases involve employers with arbitration experience, employees see much lower win rates and award amounts (Colvin, 2011). Issues of fairness also arise when arbitrators and employers are repeatedly paired with one another; plaintiffs experience the same lack of success (Colvin, 2011). Additional research discusses arbitration in terms of speed and cost-effectiveness; quicker resolution leads to lower costs and increased productivity (Schwartz, 2008, Sherwyn et al., 2005).

Win rates and speed are only small pieces of the puzzle, though, and overreliance on them can be misleading. Ghodoosi and Sharif (2021) argue that most empirical arbitration studies focus on win and loss rates, which shape our opinion of the process and affect behavior. They cite the ubiquity of arbitration yet also note that consumers have low usage rates. Perhaps low usage is due to the fact that consumers fail to read contracts and disclosures, many of which include arbitration (White and Mansfield, 2002). According to Ghodoosi and Sharif (2023), people tend to follow the *arbitration effect*—an individual is less likely to pursue justice through arbitration than in the court. Studies show that the perception of justice in the court system is higher than in arbitration (even when the outcome may be in the plaintiff’s favor) because consumers universally tend to believe that courts are fairer than arbitration (Schwartz, 2008); familiarity is higher with litigation, and people view it as more legitimate than arbitration, regardless of the costs (Ghodoosi and Sharif, 2021,0).

Other than arbitration phenomena and statistics, researchers also study specific application sectors. Liu (2023) examines arbitration in the field of intellectual property, where violations have global reach and can sometimes conflict with international law. He notes many of the same critiques of arbitration—the process is secretive enough that results are rarely published; if published, results are typically anonymous; and international courts have little oversight on the fairness of the process, only intervening for procedural mistakes. Cutler and Lark (2022) argue that arbitration, while used in global supply chain governance processes, carries hidden costs as power is redistributed between corporations and states. Subsequently, state efforts to regulate in the name of public interest are occluded.

Arbitration is attractive due to the time length of litigation. However, with fewer court decisions and a dearth of published arbitration results, there is little legal precedent established in order to develop intellectual property laws (Liu, 2023). Calls for arbitration in the health sector are also growing in number, with supporters promoting it as a cheaper alternative to litigation. Since arbitration usually skips the procedural mechanisms found in traditional litigation, it widens the “power differential between plaintiff and defendant” (Staszak, 2019, p. 270). In the area of medical malpractice, Staszak (2019) reports increased favoritism shown to medical defendants (e.g., hospitals, doctors, care organizations). Business is also an area where arbitration is routinely employed. Schwartz (2012) refers to forced arbitration as *claim-suppressing arbitration* because the intentional design reduces the number and size of plaintiff claims. He argues that rises in arbitration cases are not a matter of reducing costs; arbitration reduces the number of class action lawsuits, which are headaches for corporations. Hershkoff and Norris (2023) comment on the skillfulness at which corporations manipulate jurisdictional rules. They surmise that because arbitration doctrine prevents access to local (state) courts, plaintiffs are forced into federal court, which is viewed as less friendly to plaintiffs and amenable to defendants. An estimated 80% of private sector employees will be under an arbitration clause by 2024, and since arbitration results are generally protected from judicial oversight, corporations will continue to use the process as a “get out of jail free” card (Hershkoff and Norris, 2023).

Colvin and Gough (2023) conduct a review of mandatory employment arbitration, citing the paucity

of research due to the private, inaccessible nature of arbitration. They reveal several generalizations from growing empirical arbitration research: employee win rates and award amounts are lower, increased case docket time, arbitration caseloads are decreasing even though the process is more accessible than court, and evidence is growing of the repeat-player effect. Although there is wide agreement on lower success rates in arbitration versus litigation, there is disagreement on the interpretation. Studies continue to examine the confounding variables present in this regard, but [Colvin and Gough \(2023\)](#) conclude that mandatory arbitration has a negative effect on employees because claims are heard in an arena with a lower likelihood of success. [Mahony et al. \(2005\)](#) design an experiment to test several hypotheses related to mandatory employment arbitration. Their results suggest that employee candidates are negatively attracted to an organization when a mandatory arbitration clause is presented, with this association magnified for minorities. [Farmer \(2012\)](#) argues for reform to the mandatory arbitration process, including enforcement by government attorneys and state adjutant generals. Even in the case where a national arbitration agency (e.g., AAA) is used, corporate drafting of the agreement and selection of the arbitrator lead to a repeat-player advantage ([Bingham, 1997](#), [Colvin, 2011](#), [Farmer, 2012](#)). This selection bias is hard to detect through legal means; [Farmer \(2012\)](#) argues that the current system is set up to promote bias because stricter selection guidelines also entail dramatic cost increases.

3.2 Dispute Resolution

While some include arbitration as a form of alternative dispute resolution (ADR), we separate the terms here to focus on DR in the digital world, both online and with blockchain. Terms vary in this space, and we list a few of them to familiarize the reader: decentralized dispute resolution (DDR), distributed conflict resolution (DCR), distributed (or decentralized) justice (DJ), on-chain dispute resolution mechanisms (OCDRM), and online dispute resolution (ODR). Where appropriate, we call out the difference in meaning. DDR is generally understood to imply that blockchain technology is used to conduct DR with decentralized decision-makers ([Cianci et al., 2024](#)).

Researchers identify a few potential advantages of blockchain-based DR: quicker resolution than court and private arbitration ([Cianci et al., 2024](#), [Ustun and Yuce, 2022](#)), increased transparency ([Xue and Holz, 2019](#)), reduction in cost ([Cianci et al., 2024](#), [Ustun and Yuce, 2022](#)), increased security and anonymity for decision-makers ([Cianci et al., 2024](#)), potential to minimize corruption ([Ustun and Yuce, 2022](#)), and readily available oracle connections facilitate arbitration ([Ortolani, 2019](#)). There are, however, more challenges identified with using DDR. The most prominent criticism of DDR deals with policy and governance; results are not officially recognized by governments, calling into question the validity of a decision made by someone without subject expertise or proper legal background ([Cianci et al., 2024](#), [Goldenfein and Leiter, 2018](#), [Ustun and Yuce, 2022](#)). Other criticisms include the inability to replicate off-chain alternatives without sacrificing fundamentals such as anonymity, solutions at scale, etc. ([Buchwald, 2019](#)); smart contract ineffectiveness for anything other than deterministic agreement elements ([Ortolani, 2019](#)); enforceability ([Cianci et al., 2024](#), [Goldenfein and Leiter, 2018](#)); the difficulty of post-adjudication legal action or legal misunderstandings, in general ([Ortolani, 2019](#), [Xue and Holz, 2019](#)); the inability to model human reason ([Xue and Holz, 2019](#)); and voter selection, reliability, and tampering ([Cianci et al., 2024](#)). [Ortolani \(2019\)](#) also explains several contradictions with a resolution by smart contract: while blockchain technology rejects external judgment authority, private adjudication systems are created as a by-product of DDR; the rise of blockchain does not render courts obsolete but rather leads to an increase in the number of cryptocurrency litigation cases.

Despite the many challenges, there are some real applications of the DDR process. DJ is sometimes reserved for a specific platform that handles disputes. Supporters argue that the ODR industry needs to grow faster because of the increase in e-commerce disputes ([Aouidef et al., 2021](#)). Platforms such as Kleros, Aragon, and Jur are already proving to be viable arenas for justice in the digital market. Kleros, for example, is an Ethereum-based dispute platform that selects three crowd-sourced jurors at random ([Stuart James, 2019](#)). Jurors are selected proportionally based on the amount of cryptocurrency stake submitted. The voting decisions are binary, and a juror is penalized for not siding with the majority; this can, however, lead to a monopoly as a higher reputation also increases the likelihood of selection ([Zhuk, 2023](#)).

DR is also slowly making progress in the construction industry. [Cheung et al. \(2004\)](#) propose CoNegO, an early online dispute negotiation program that performs calculations to determine settlement amounts. [Ojiako et al. \(2018\)](#) conduct a survey of construction stakeholders to examine the legal ramifications of ODR.

They recommend an increased usage of ODR for more efficient communication between parties. [Saygili et al. \(2022\)](#) propose a new blockchain-based ODR platform called Decentralized Constructing Enabling Transparent Resolution (DCENTR). They demonstrate a cheaper and quicker form of DR, which includes a separate justice component (JUS-DCENTR) for disputes that utilizes a random selection of crowdsourced jurors.

3.3 Third-party Incorporation

Multiple attempts at utilizing escrow accounts or principles have advanced research in the realm of third-party incorporation. Some researchers aim to devise a two-party solution and eliminate a third party, while others use a third party as a traditional escrow agent. Within the third-party solutions, there is a heavy emphasis on attacks, such as a collusion attack or denial-of-service (DoS) attack. In the former, an ARB or third party colludes with a buyer or seller; in the latter, a third party denies access to funds or goods by refusing to arbitrate.

[Meng et al. \(2019\)](#) propose Themis, an escrow-based fair exchange protocol designed to alleviate these issues. However, the authors still use an arbitration service (crowdsourced mediation from trust network members). A fee is paid once participants decide that a dispute is reached; an odd number of ARBs are chosen based on a reputation score, and they earn rewards for good behaviors. Nevertheless, there are still criticisms of this model. Namely, Themis does not prevent off-chain collusion, the algorithm is not descriptive in the fee breakdown, the mediators are assumed to be neutral, and Themis is branded as a decentralized protocol without third parties. [Goldfeder et al. \(2017\)](#) use Bitcoin to design better escrow protocols under the assumption that payment is physically transferred to a third party responsible for the delivery of funds. While [Goldfeder et al. \(2017\)](#) identify potential issues with mediator misbehavior, it is not always desirable to hand payment over to a third party. [Asgaonkar and Krishnamachari \(2019\)](#) suggest a design of a strictly two-party payment system for exchanging digital goods without a third party using a dual-deposit scheme. While this is similar to the stake philosophy employed in the previous chapter, the authors rely on game-theoretic principles to justify outcomes, i.e., the subgame perfect Nash equilibrium suggests that all parties behave honestly, but this is not always realistic. [Goharshady \(2021\)](#) argues that no smart contract can facilitate the exchange of physical goods without reliance on a third party or enabling one side to extort the other. Furthermore, he criticizes most escrow designs operating under the assumption of simultaneous play in a two-player, non-cooperative game. Given that smart contracts operate more so in a sequential manner, whereby a user witnesses a transaction and can change their response, this assumption is faulty. The ability to change a response can leave the contract vulnerable to an extortion attack. [Goharshady \(2021\)](#) also highlights issues with more traditional third-party systems like Amazon, which employ high fees. [Schwartzbach \(2021\)](#) proposes a smart contract escrow system to facilitate physical goods and services transactions between two distrusting parties. Once again, the results are based on game theory; buyer and seller honesty is dependent on belief in an unbiased ARB. However, participants must pay a wager representing the belief in a successful outcome, along with submission of an evidence string, so this not only resembles legal proceedings, but it does not emphasize the neutrality of an ARB.

[Zimbeck \(2014\)](#) proposes BitHalo, a two-party escrow system for Bitcoin. With BitHalo, funds are sent to an escrow account, and if one party breaks the commitment, a fee is deducted from the guilty party and paid to miners. However, it is unclear how cheating is identified, and this only covers the sending of digital currency and not some good or service. [Viktorov and Hollands \(2018\)](#) propose EscrowBlock, a system in which a deposit is sent to a multi-signature wallet, which is separate from the primary smart contract. Arbitration is performed by a body of appointed nodes based on the amount of tokens that the nodes possess. As this is merely another version of reputation, it seems that only the richest nodes serve as ARBs. [Cheung \(2019\)](#) utilizes an escrow system for sending and receiving Ether. The buyer and seller choose an escrow agent, but the agent can charge a fee that is only payable by the seller. Thus, the imbalance in fees is assumed to be negated by the usage acceptance of the system, which is not necessarily realistic. [LocalCryptos \(2023\)](#) showed promise as a peer-to-peer trading mechanism with a self-custodial escrow account, but it closed in 2022 after only five years.

3.4 Project Management

The concepts and tools of project management are beyond the scope of this research, so we focus on efforts to use blockchain in a project. For project management concepts, the interested reader should consult [Kerzner \(2017\)](#); for guidelines in conducting theory-based project management work, consult [Ahlemann et al. \(2013\)](#). Project management is defined as the “application of knowledge, skills, and tools necessary to achieve the project’s requirement” ([Kerzner, 2017](#), p. 2). Because of the many sequential layers to project management, blockchain is an ideal candidate for implementing project components. However, research into the intersection of these fields is still developing.

[Sharma et al. \(2023\)](#) examine smart contract use in project management, identifying these advantages: reduced costs, increased transparency, enhanced trust, and reduced intermediaries. On the contrary, security, scalability, and regulatory compliance are still challenges to the incorporation of blockchain into project management. In their survey of 200 project managers using smart contracts, [Sharma et al. \(2023\)](#) discover positive feedback about efficiency and cost reduction compared to traditional project management methods. [Sonmez et al. \(2021\)](#) review current blockchain research in project management, concluding with a framework for determining the blockchain network type and platform for a particular project management scenario. They also classify blockchain contributions to project management into four categories: building trust, enhancing communication, reducing disputes and claims, and preventing fraud. [Meng and Sun \(2021\)](#) apply a blockchain-based project management process to the administration of a scientific research program. Their simulation results highlight stronger privacy, higher project completion success rates, and quicker execution. [Lu \(2023\)](#) experiments with using blockchain in a water transportation project. The results highlight positive outcomes: reduced costs, faster execution, better quality, and greater collaboration through enhanced information sharing. Construction is also an attractive area for blockchain and project management. Large, often distributed construction projects require integration, scheduling, and leadership. Recent research reveals drastic improvements in time and cost savings, but blockchain networks require updates to handle scaling and connection issues ([Zhao et al., 2023](#)). Furthermore, the construction industry shows promise for blockchain-based project management when combined with artificial intelligence (AI) and building information modeling (BIM) by helping to ensure projects remain within budget limits ([Li et al., 2021](#)).

4 Modeling

4.1 Framework

A short orientation to the previous work of [Fukuzawa et al. \(2024\)](#) is necessary to give the reader appropriate background. Figure 1 displays the blockchain-based contracting process using smart contracts. The three primary drivers in this process are the Scope of Work Contract (SoWC), Payment Contract (PC), and Job Progress Contract (JPC). Their roles are to capture job requirements, coordinate payment collection and transfer, and manage job verification status, respectively. Within the Scope of Work Contract, the client (CLT) and contractor (CTR) negotiate the terms of the agreement, which may include specific conditions of the particular job. The SoWC also includes a process for verifying CTR credentials, such as licensing and insurance information. This verification process is (assumedly) managed via a connection to an off-chain database made possible by oracles (see Figure 1 (1j)). Once the negotiation is complete, the process then handles payment from both parties; the funds remain in this contract until project completion. Note it is assumed that the necessary conversions to typical paper currency are available (also via oracles), given that Ethereum smart contracts only accept ETH cryptocurrency. An off-chain process includes the use of digital imagery to verify job status and the CLT signals job completion in the JPC.

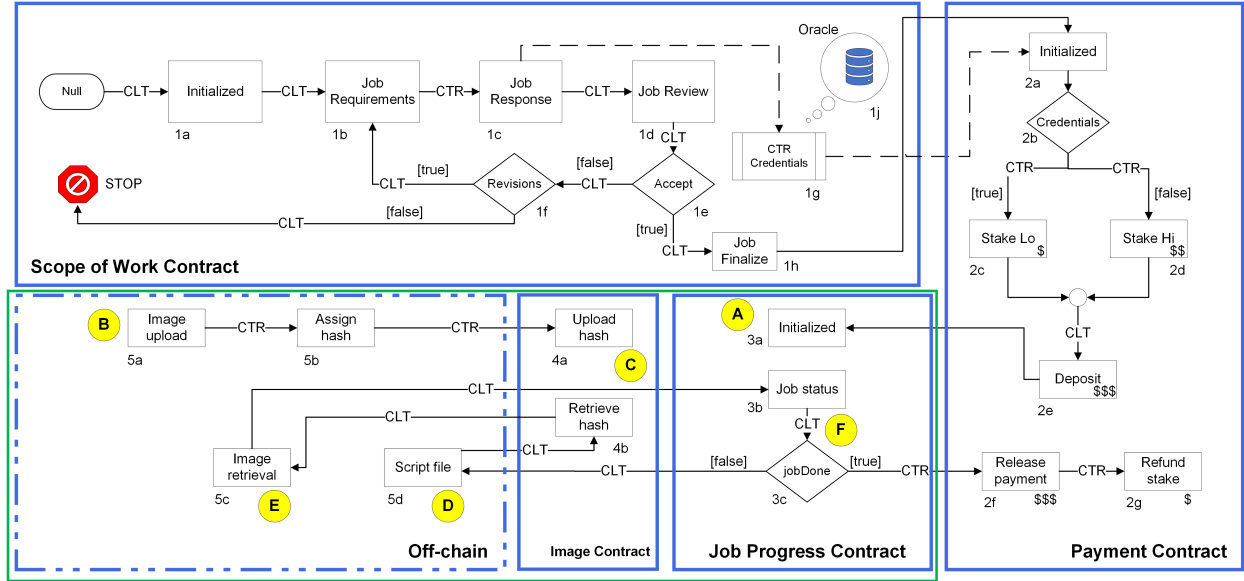


Figure 1: Base design process (adapted from Fukuzawa et al. (2024)).

We extend the work by Fukuzawa et al. (2024) through the use of two example scenarios. These scenarios are not meant to depict all possible schemes, nor do they address all previous assumptions by Fukuzawa et al. (2024). Instead, we use them to highlight specific actions to either improve the original process or to capture more realistic conditions.

4.2 Scenario #1

The first scenario assumes that an agreement is initiated between CLT and CTR for work in the same manner as presented in Fukuzawa et al. (2024). However, we modify those conditions by assuming that the CLT is unable to verify job completion. While the specific reason is unimportant, we might surmise that there are questions surrounding the quality of work or accuracy based on the initial contract terms. This slight difference from the work of Fukuzawa et al. (2024) is meant to induce more realistic conditions; not every job is completed with no issues. Another major modification to this scenario is including an internal arbitration service. To support this service, an Arbitration Contract (AC) is added to handle arbitration related payments. Figure 2 conveys the major contracts of this new scenario along with their primary actions. While the layout may imply linear sequencing of events, this is only for convenience of display; some contracts interact with multiple others in a non-linear fashion.

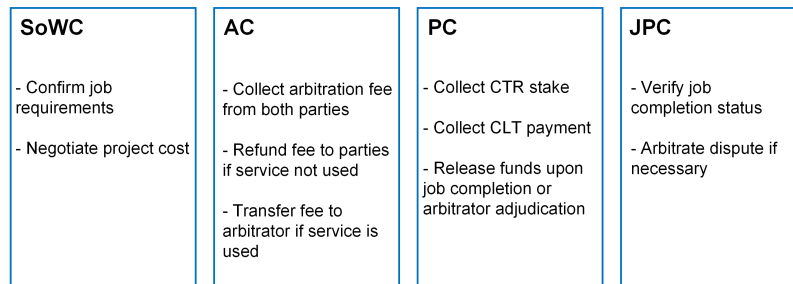


Figure 2: Contract layout of Scenario #1 (created by authors).

4.2.1 Assumptions

In order to model this scenario, we make the following necessary assumptions:

Cost: The CLT wants the lowest cost overall; CTR is still profit-seeking but wants to minimize 3P costs. Parties agree to the arbitration fee during contract negotiation.

Trust: There is no trust between parties.

Honesty: The CLT is not intentionally involved in a dispute in order to avoid payment nor are they deceitful when assessing job progress in order to recoup the deposit. Likewise, neither party is attempting to delay progress, e.g., avoiding arbitration. However, we do allow for ignorance and incompetence, e.g., CTR does not know how to complete the project but does not reveal this aspect, or CTR completes a portion of the project incorrectly but does not inform the CLT. We assume that parties understand the evidentiary requirements if arbitration is sought for these cases.

Human Behavior: Certain aspects of likely human thinking are assumed. Where appropriate, we make note of these thoughts.

Evidence: The ARB does not have access to any elements beyond what is recorded on the blockchain. Additionally, we assume an appropriate time is spent reviewing evidence so as not to become a burden to the parties or rival the length of current arbitration and litigation methods. The entire review and decision process is assumed to happen quickly.

Design: Original base case contract elements from Figure 1 are still present.

Transparency: All parties have knowledge of the process structure and understand the cost breakdown and evidence requirements; participation assumes acceptance of methods.

Arbitrator: The service provider supplies properly vetted mediators and manages any conflicts of interest appropriately; the 3P process is assumed to be fair and recognized as such by the participants.

Arbitration Type: Binding arbitration is employed here; parties accept this through participation. Binding is chosen due to the assumption of cost minimization; with rejection of non-binding outcomes, participants would likely spend more to pursue legal action.

Oracles: External connections exist as needed to pull the appropriate data from sources, e.g., ETH conversion rates to USD, credentialing verification, etc.

Code efficiency: The code is not optimized for efficiency and security. Further work is needed to examine this aspect.

Other assumptions are merely for simplification.

Reliability: The specific rationale for the dispute is unimportant; perhaps the CTR is incompetent or lacks attention to detail. Both parties have a reasonable argument to justify their position.

Fee Structure: We arbitrarily use a 1% (of the total project cost) arbitration fee here for demonstration; the fee is a one-time payout. Project costs are hard-coded to simplify the demonstration; we assume oracle and/or offline connections are present which manage the conversion rates and calculations required. Once again, the conversion rates from May 2023 consistent with [Fukuzawa et al. \(2024\)](#).

Process Actions: Many of the demonstration steps from the work of [Fukuzawa et al. \(2024\)](#) are assumed to have occurred; their demonstration is not necessary in this scenario.

Weather: Weather-related issues are not a cause for the dispute.

Supplies: Supply and labor shortages are not included.

Arbitration Decisions: The possible arbitration outcomes are not meant to present a universal solution to any problem; they are simple ways to resolve the dispute.

4.2.2 Description

To accommodate the AC, other modifications are made to the surrounding contracts. Due to the complexity of interactions, we separate the discussion of these modifications into several parts. In Figure 3, we only display the changes to the associated base case elements for the initial steps in the process. The CLT and CTR negotiate the same project terms (1a) as in Figure 1; the SoWC concludes with the `jobFinalize()` function, which now deploys instances of the AC (2a), PC (3a), and JPC (4a). In the AC, the CLT and CTR submit an equal arbitration fee (2b/2c); it is hard coded at 1% of the total project cost. Once both fees are paid, the AC sets the Boolean variable `arbFeesPaid` to true. This variable is checked (2d) by the PC prior to the submission of the CTR stake (3b). If `arbFeesPaid` is false, then an error message is shown indicating that the arbitration fees have not been collected. After the CTR stake is submitted (3b), the CLT is allowed to submit the project deposit (3c). At this point, we assume the physical work on the job site starts as before in Figure 1.

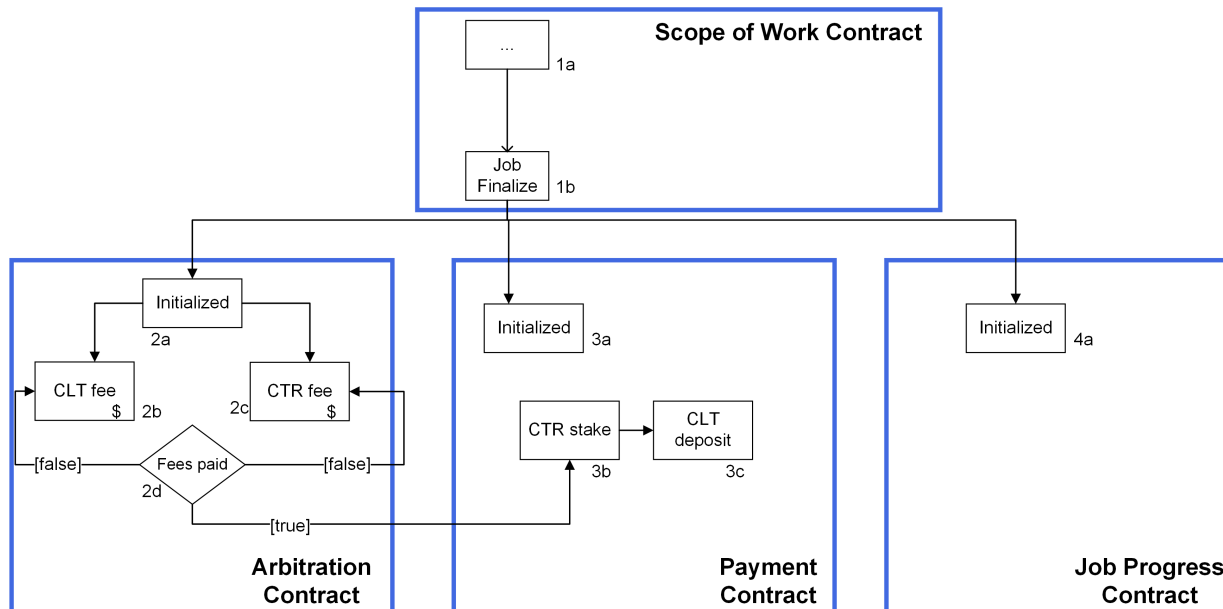


Figure 3: Scenario #1 adaptations to base process with addition of AC (created by authors).

Eventually, the CLT attempts to verify job completion, but there is disagreement about the status. We now present a dispute resolution process using Figure 4 as a reference. If a CLT accepts the job as complete (1y), then the actions from Figure 1 remain the same with the exception of a refund of the arbitration fee to CLT and CTR (1n). In the case of the first rejection (i.e., $i = 0$), the CTR has a chance to respond via a dispute function (1h). The CTR may choose to reject the dispute and hence proceed with internal resolution. Alternatively, if a dispute is confirmed, then the process heads to arbitration (1e). With internal resolution, both CLT and CTR submit comments (1i/1j) to the JPC in an attempt to communicate issues. This comment feature is a simple means to support internal resolution between the parties, but it is limited to string inputs. After the final comment (1j), the counter variable i increments by one (1k). Another attempt is made to complete the job, and the CLT reviews the CTR work again (1b). If there is still dissatisfaction, the JPC checks the counter variable (i.e., now at $i = 1$) and automatically sends the dispute to an ARB (1e). Again, we assume that this arbitration service is internally managed by a hypothetical service provider. Whenever the ARB is called, the counter variable j also increments by one.

The ARB can rule in one of three manners (1f): CLT, CTR, or NEITHER. If in favor of the CLT, then the ARB adds a time-based extension (1g) to the job to allow for further progress. If, instead, the ruling is for the CTR, then the process is terminated (1y), the ARB fee is paid (1p), and the deposit is sent to the CTR as in Figure 1. In the case of a NEITHER ruling, then the deposit is split between CLT and CTR (1r). We also consider the job complete at this point (1y), and the ARB fee is paid (1p). The dashed line in Figure 4 implies that these actions occur simultaneously. No matter which round of CLT review, the JPC checks the value of counter variables i, j , and k . At various points in the process, certain combinations of counter values automatically trigger certain events in the process. For example, after one CLT rejection and one round of internal resolution, $i = 1, j = 0, k = 0$. If the job is rejected again, the case now heads to an ARB, $i = 1, j = 1, k = 0$. Suppose the ARB votes in favor of the CLT (i.e., another chance at job completion), $i = 2, j = 1, k = 0$. With $i = 2$, another rejection automatically triggers an end to the process with a full CLT refund (1q).

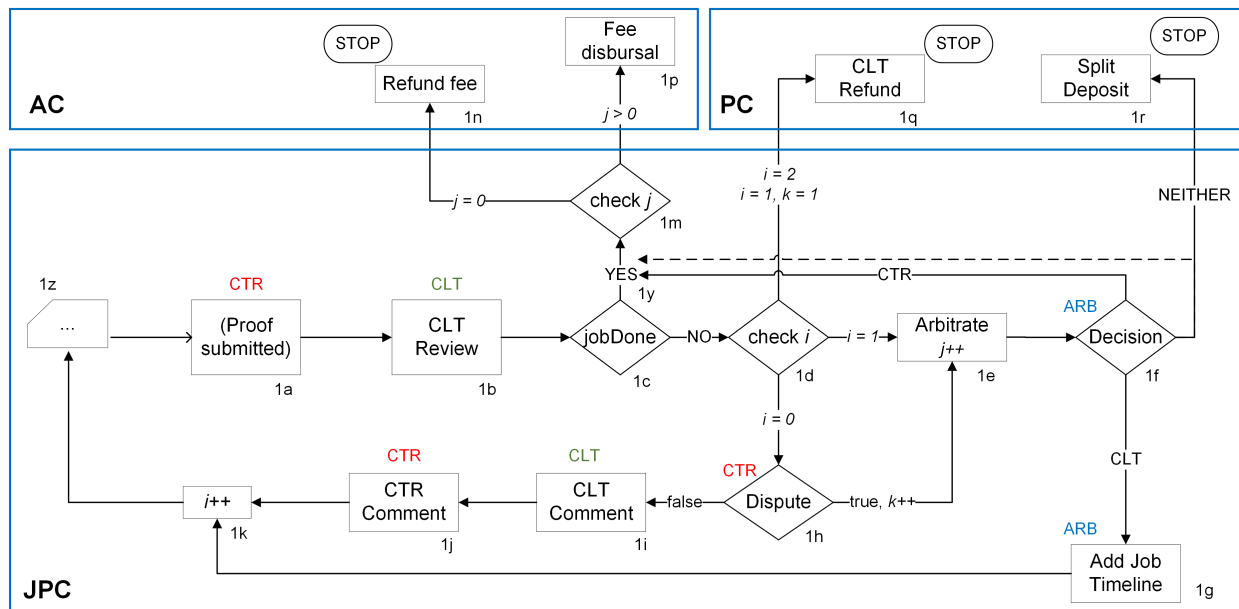


Figure 4: Scenario #1 major process interactions (adapted from Fukuzawa (2024)).

4.2.3 Demonstration

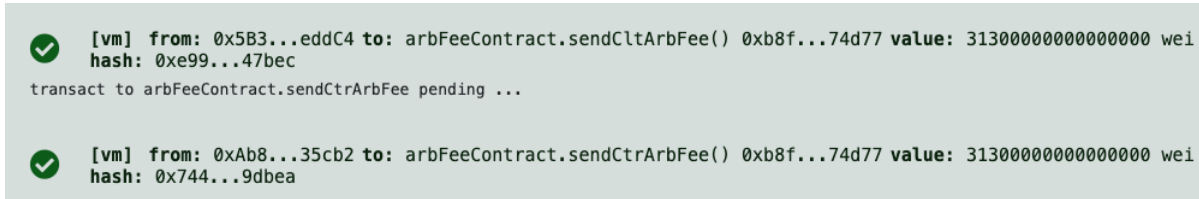
The Remix Integrated Development Environment (IDE) is used to demonstrate both scenarios. For brevity, some elements of the following demonstration are omitted; the interested reader should consult the work by Fukuzawa (2024) for more detail. The first three default account addresses provided by Remix are used to represent the CLT, CTR, and ARB (see Table 1).

Table 1: Participants and Ethereum account addresses for Scenario #1.

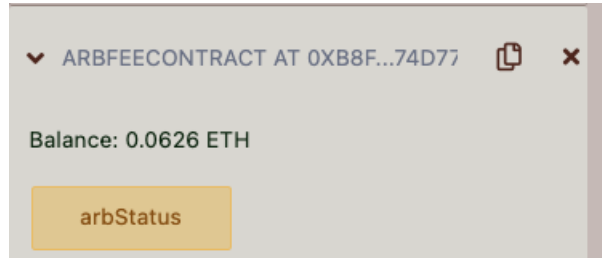
Participant	Address
CLT	0x5B38Da6a701c568545dCfcB03FcB875f56beddC4
CTR	0xAb8483F64d9C6d1EcF9b849Ae677dD3315835cb2
ARB	0x4B20993Bc481177ec7E8f571ceCaE8A9e22C02db

For ease of explanation, the same initial project parameters are used to deploy the job from Fukuzawa et al. (2024). With an instance of the AC deployed, both CLT and CTR submit the 1% arbitration fee to the AC. In the example, the fee is 0.0313 ETH (31,300,000 gwei). Figure 5 displays the Remix log output of the successful fee submission; note the same amount listed in the **value** output. Note also that the combined

total arbitration fee is held in the smart contract balance. Either party may now execute the `arbStatus()` function within the AC, which updates the Boolean variable `arbFeesPaid` to true. Recall that this must be completed prior to interaction with the PC (see Figure 3).



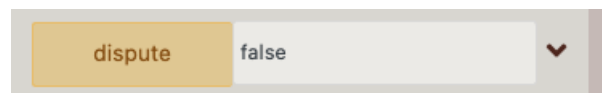
(a) Successful arbitration fees submitted, equal value by CLT and CTR.



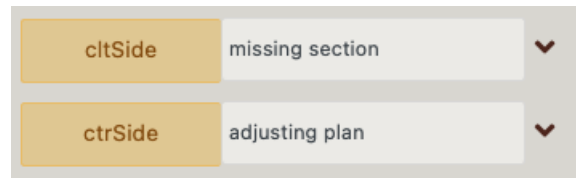
(b) Contract holds arbitration fee balance.

Figure 5: CLT and CTR arbitration fees received (adapted from Fukuzawa (2024)).

Payments, in the form of a CTR stake and CLT deposit, are received by the PC in the same manner as described in Fukuzawa et al. (2024). We skip ahead to the job review, assuming now that the CLT is dissatisfied with the progress; the CLT executes the `jobNotDone()` function. Recall from Figure 4, at this first rejection of job completion, the JPC checks the value of the counter variable i . In this case, $i = 0$, and the contract gives CTR access to the `dispute()` function (1h). For demonstration purposes, assume that the CTR wants to avoid arbitration and settle the dispute internally. Thus, the CTR enters a value of *false* (see Figure 6). Both parties are now able to submit string comment inputs to simulate digital dispute resolution (see Figure 6).



(a) CTR submits false.



(b) CLT and CTR comments.

Figure 6: Internal resolution path (adapted from Fukuzawa (2024)).

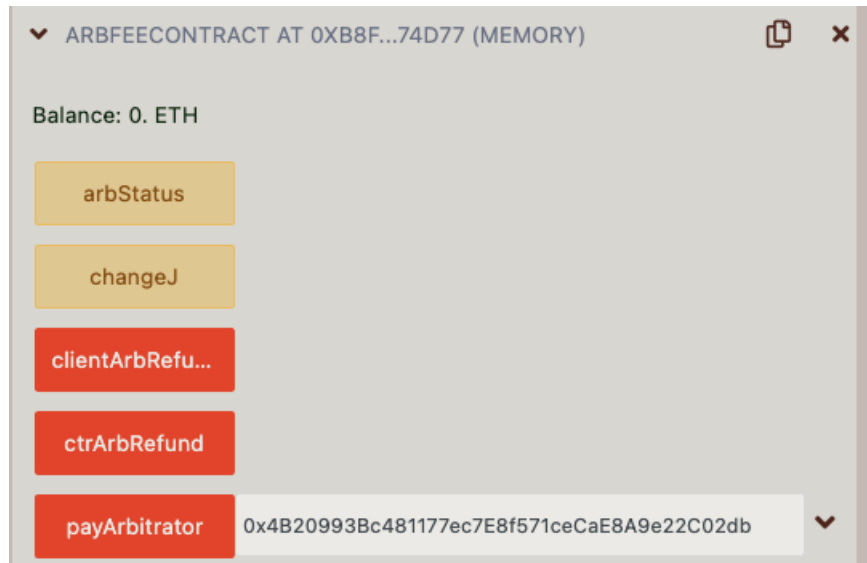
After some attempt to fix the issue, another review of progress ensues. If the CLT is still dissatisfied, then another call to the `jobNotDone()` function activates arbitration (i.e., $i = 1$). The ARB is now called in to adjudicate the situation (Figure 4, (1f)), and we demonstrate the ARB interaction via functions in the JPC. In the simplest case, the ARB rules in favor of the CTR by entering the appropriate value in the `arbDecision()` function within the JPC (see Figure 7). This immediately marks the job as complete;

payment is made in the same manner as described in [Fukuzawa et al. \(2024\)](#).

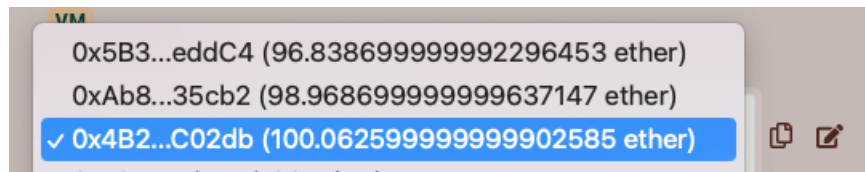


Figure 7: ARB rules in favor of CTR (adapted from [Fukuzawa \(2024\)](#)).

The only new addition here is that the arbitration fee is now paid to the ARB. Using the `payArbitrator()` function in the AC, the ARB submits their account address as input, and the payment is transferred. Note in [Figure 8](#) that the AC balance is zero upon successful execution of the `payArbitrator()` function.



(a) Execution of payable function.



(b) Account balance updated.

Figure 8: ARB fees dispensed (adapted from [Fukuzawa \(2024\)](#)).

The ARB may instead decide that neither party is entitled to the ruling; see [Figure 9](#). Perhaps the ARB believes that both sides maintain equally valid claims, although the specific reason is unimportant for this demonstration. As diagrammed in [Figure 4 \(1r\)](#), the deposit is split between the CLT and CTR.

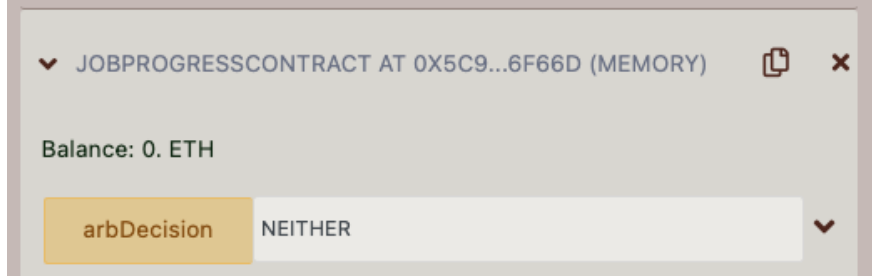
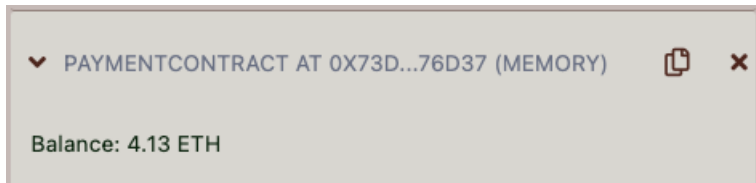
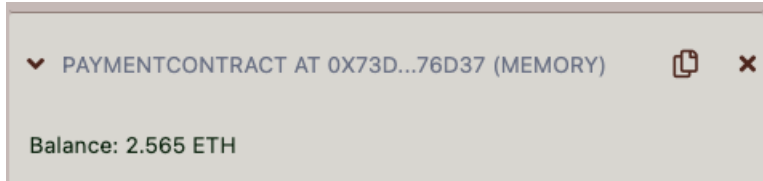


Figure 9: ARB ruling for neither party (adapted from Fukuzawa (2024)).

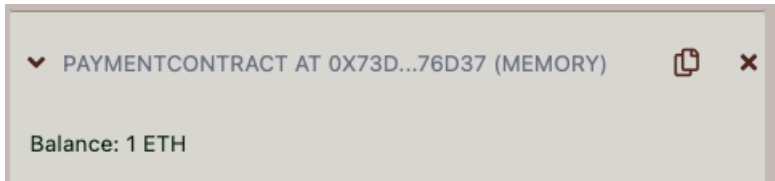
With a NEITHER ruling, both CLT and CTR are now allowed access to refund functions in the PC, which split the deposit in half. In our example, the total job cost is 3.13 ETH (or 3,130,000,000 gwei); 1.565 ETH (or 156,500,000 gwei) is refunded to each party. Recall, this amount is hard-coded for simplification, but we assume the presence of oracles to manage these calculations in an actual implementation. Figure 10 shows the refund decrements to the PC, leaving only the CTR stake once the deposit is transferred.



(a) PC balance before arbitration outcome.



(b) PC balance after CLT receives half refund.



(c) PC balance after CTR receives half refund; only CTR stake remains.

Figure 10: Payment progression for NEITHER ruling (adapted from Fukuzawa (2024)).

The stake is a technique for deterring CTR dishonesty and malfeasance (Fukuzawa et al., 2024). However, we do not explore any usage of the stake in this scenario; it is simply refunded to the CTR at the end of the project. The final ARB case involves a ruling for the CLT, and it is slightly more complicated. Based on Figure 4 (1g), the CLT ruling triggers a time limit. The intent here is to give parties additional time to complete the project before the ARB must take action against payment funds. In this example, we add 24 hours to the current clock time, and the variable i iterates by one (although this figure is arbitrary and could be set to any amount of time). Figure 11 shows the addition of a `timeLock` variable which holds the time limit.

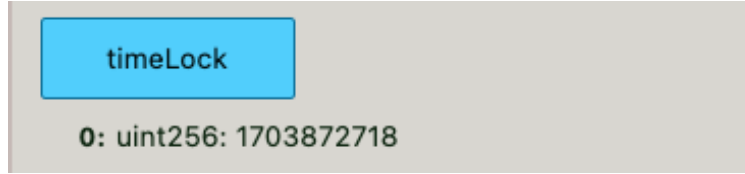
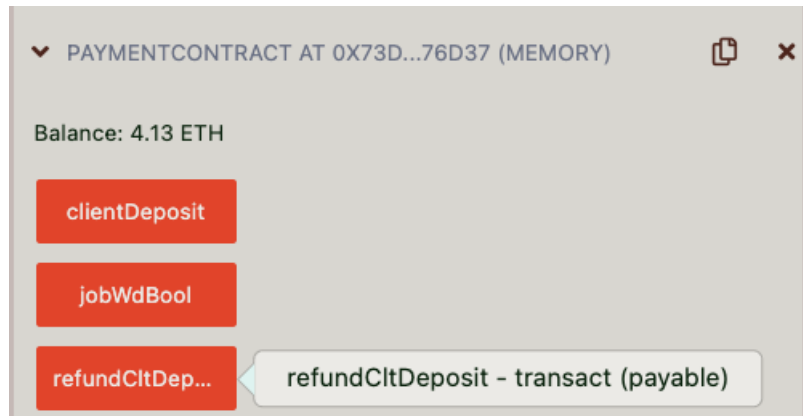
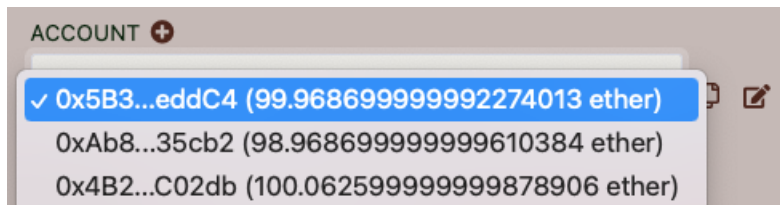


Figure 11: New time limit added (adapted from Fukuzawa (2024)).

Following another progress review, the CLT may still accept or reject the job. With a rejection at this second pass (i.e., $i = 2$), there are no more arbitration options. The CLT is awarded a full refund (Figure 4, (1q)), which is performed for simplification. With the CLT call to the `refundCltDeposit()` function, the deposit of 3.13 ETH is transferred back to the CLT's account in Figure 12, and the project terminates.



(a) CLT refund function for full deposit.



(b) CLT account updated.

Figure 12: Process of full CLT refund after arbitration ruling (adapted from Fukuzawa (2024)).

We now explore a different outcome related to the initial CLT rejection of job completion. Suppose that immediately following the first CLT rejection, the CTR instead confirms a dispute (Figure 4, (1h)). In Figure 13, the CTR performs this action with the `dispute(true)` function. The ARB then proceeds with the adjudication process, for which all of the options are previously shown.

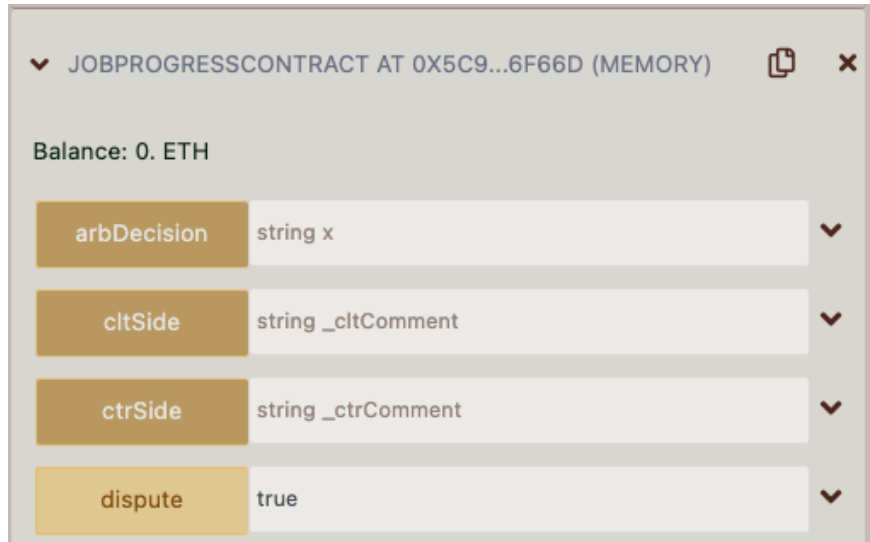


Figure 13: CTR chooses arbitration immediately (adapted from Fukuzawa (2024)).

4.3 Scenario #2

The second scenario adds structure by way of project management concepts. We still demonstrate the process on the basis of some dispute between CLT and CTR, and an arbitration service is still offered. The major modifications to this scenario include the creation of a milestone (MS) schedule and a task-based arbitration ruling. The same AC from the first scenario is still present, but a Project Schedule Contract (PSC) is added to handle project requirements.

4.3.1 Assumptions

All assumptions are identical to Scenario #1 except the changes identified below.

Project structure: The contract negotiation includes a detailed breakdown of the project milestones and expected task completion schedule. Although the tasks have an associated time duration, the CLT may verify task completion at any point in time.

Arbitration type: Again, binding arbitration is employed here, but we further assume that the basis for ARB decisions is agreed to in the contract negotiation/arbitration agreement phase.

Arbitration timing: Arbitration is not allowed until the projected time for completion has passed. This avoids any debate about refund amounts in the middle of a project.

Project structure: We demonstrate the concept on a simple project with four milestones (A–D) and five tasks (1–5).

Project scope: The job is projected to last nine hours.

Project progress: The CTR completes the tasks required by MS A, but fails to complete the remaining tasks by the other milestones.

Payment Structure: With four payments corresponding to the four milestones, we divide the CLT deposit equally. Additionally, when an arbitration decision is rendered, we equate project completion with milestones verified, e.g., if three out of four milestones are verified, then 75% of the project is complete, and three partial payments are issued to the CTR.

4.3.2 Description

We introduce structure to this scenario in the form of the PSC; it is depicted as a separate contract in Figure 14 for ease of organization. After project initialization with the SoWC, the CTR uploads a work breakdown structure (WBS) in the form of a numbered task and associated time estimate (2a). The CTR also enters a time estimate for the total project (2b). The CLT responds with an assignment of milestones to the task list, creating a MS verification schedule (2c/2d). The CTR has final approval over this schedule (2e). The same arbitration and payment requirements from the first scenario still apply.

Once the job begins, the CLT observes progress via the same off-chain verification mechanism presented in Figure 1 (Fukuzawa et al., 2024). As MS are reached, the CLT verifies completion with a `msVerify()` function (3c). Note, the task time estimates entered into the PSC are not prohibitive; they do not hinder nor enable action and are merely for reference. However, if the project time has passed (2b) and work still remains, the CLT may now request arbitration (3e). The service provider adds an ARB to the process, who reviews progress based on the digital evidence and MS verification status. The ARB decision (3g) involves a quantitative breakdown of the CLT payment according to the work completed. This decision is passed to the PC, which divides the CLT payment among the two parties. The arbitration fee is also dispensed as previously described. This process is examined further in the demonstration.

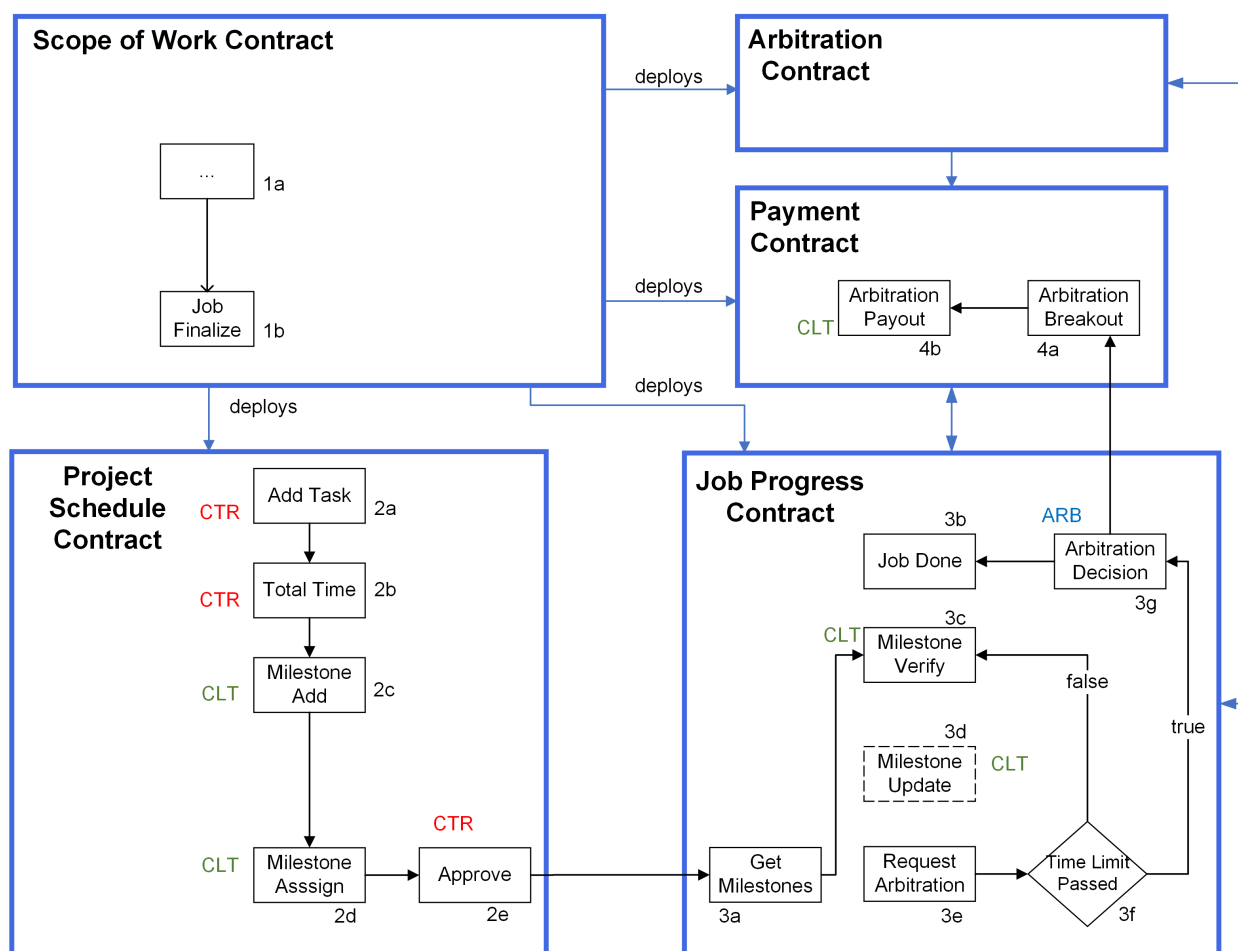


Figure 14: Scenario #2 major interactions and function flow (created by authors).

4.3.3 Demonstration

For simplicity, the same Remix account addresses are used from Table 1 to represent the CLT, CTR, and ARB, respectively. Also, we utilize the same simple project scenario of building a fence from Fukuzawa et al.

(2024). To accommodate the demonstration, we assume that the project schedule follows the breakdown in Table 2.

Table 2: Scenario #2 task breakdown.

Project: Install fence Time: 9 hrs	
Task	Duration
1	3 hrs (180 min)
2	2 hrs (120 min)
3	0.5 hrs (30 min)
4	2.5 hrs (150 min)
5	1 hr (60 min)

The task breakdown feeds the MS schedule for verification, which is borrowed from project management techniques (Kerzner, 2017). Suppose the CLT approves the MS assignment in Table 3. Note that the MS are also associated with a partial payment (PP) plan. Although we do not explore disbursement of partial payments here, this example can be extended to include dynamic payments for larger scale jobs like those found in construction research (Ahmadisheykhsarmast and Sonmez, 2020, Das et al., 2020). Instead, the payments here represent a proportion of the total deposit earned.

Table 3: Scenario #2 MS schedule.

MS	Deliverables	Partial Payment (PP)
A	Task 1	PP 1
B	Tasks 2, 3	PP 2
C	Task 4	PP 3
D	Task 5	PP 4

For brevity, we omit the initialization measures from the SoWC. The CTR utilizes the `addTask()` function to add tasks and times, which are compiled into arrays. Time is entered in minutes to avoid Solidity issues with floating point numbers, as shown in Figure 15.

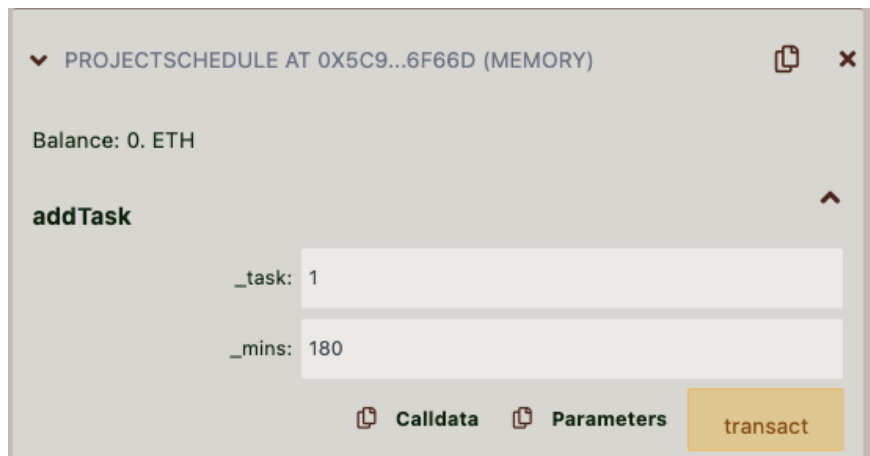


Figure 15: CTR task input (adapted from Fukuzawa (2024)).

Upon conclusion of the task input, the CTR enters a total projected job time (in minutes) with the

`totalTime()` function (see Figure 16). This time threshold only sets a mark for an arbitration request. With the `viewTimes()` function, the current clock time and projected end time are viewable.

The screenshot shows a light gray rectangular box containing a yellow button labeled 'totalTime' on the left. To its right is a white input field containing the number '540'. On the far right of the box is a small dark gray downward-pointing arrow.

(a) CTR enters total project time.

The screenshot shows a light gray rectangular box. At the top left is a blue button labeled 'viewTimes'. Below it, centered, is a black text string: 'O: string; Now:1704678999; Finish:1704711381'.

(b) Current time and projected end time.

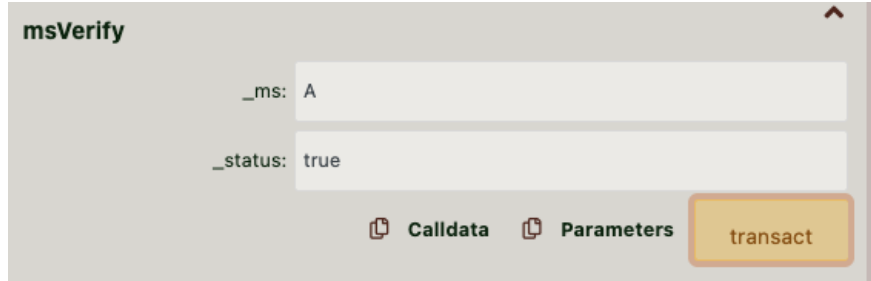
Figure 16: Time functions (adapted from Fukuzawa (2024)).

Once the total time is entered, the CLT proceeds with the MS assignment. This consists of an integer input representing the total number of MS and a mapping of MS to task. In Figure 17, the CLT submits four MS to the `msAdd()` function per Table 3. Additionally, MS A is assigned to Task 1. Note that the extra input field in the `msAssign()` function accommodates the multiple task assignment to MS B. A zero entry simply conveys that only one task is assigned to this MS. An error check function `testMsLength()` ensures that the CLT assigns the correct number of MS per the `msAdd()` function. Once satisfied, the CTR executes the `ctrApprove()` function, which allows access to verification functions in the JPC. We assume that any disagreement over MS assignment is internally debated and resolved before CTR approval of the schedule.

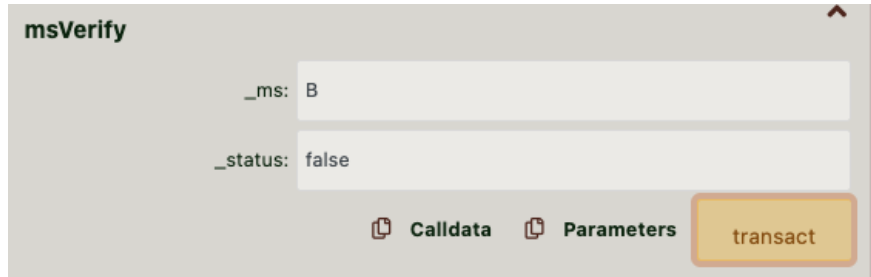
The screenshot shows a light gray rectangular box. At the top left is a yellow button labeled 'msAdd' with the value '4' in a white input field to its right. Below this is a section titled 'msAssign' with a small upward-pointing arrow to its right. Under 'msAssign' are three input fields: the first contains '_ms: A', the second contains '_task1: 1', and the third contains '_task2: 0'. At the bottom of the box are three buttons: 'Calldata' (with a clipboard icon), 'Parameters' (with a clipboard icon), and 'transact' (in a yellow box).

Figure 17: CLT MS entry (adapted from Fukuzawa (2024)).

Milestone verification occurs in the JPC with the `msVerify()` function. This function accepts two inputs: MS and Boolean true/false. A value of *true* indicates that the MS is verified by the CLT; *false* implies that the MS is unverified. In Figure 18, the CLT approves the work completed assigned to MS A but claims the next two tasks are not complete by MS B.



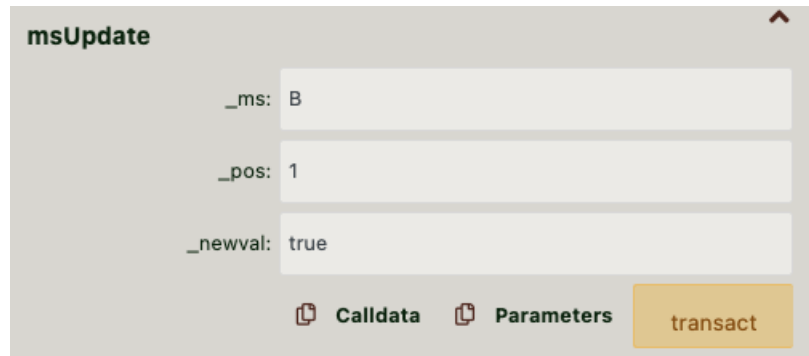
(a) MS A complete.



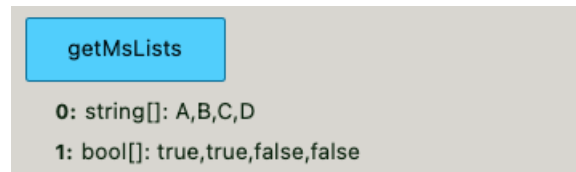
(b) MS B incomplete.

Figure 18: CLT verification of MS progress (adapated from Fukuzawa (2024)).

There is also some built-in flexibility with a rudimentary optional `msUpdate()` function. Suppose the CTR completes the MS B tasks at a later time. The CLT can update the verification status, but they must know the index position of the MS in its array. Using zero-based indexing, MS B is updated to reflect completion in Figure 19. For the purpose of this demonstration, however, we do not explore further usage of the `msUpdate()` function. When the time limit expires, the CLT verifies MS A as complete and the remaining ones as incomplete.



(a) CLT update to MS B.



(b) MS status after update.

Figure 19: MS status updates (adapated from Fukuzawa (2024)).

Suppose the CLT desires arbitration; this request is made with the `requestArb()` function in the JPC. This function first checks that the project time limit set in the PSC has expired. If satisfied, the ARB engages the process with the `arbMsDecision()` function. By our assumptions, recall that MS A is verified while the remaining ones are not. In Figure 20, the ARB reviews the evidence and determines that the CTR is awarded one MS and the CLT is awarded three. With this function execution, the `jobDone` variable is set to `true`, and the interaction ends. The arbitration fee is still paid out, as shown in Scenario #1, Figure 8.

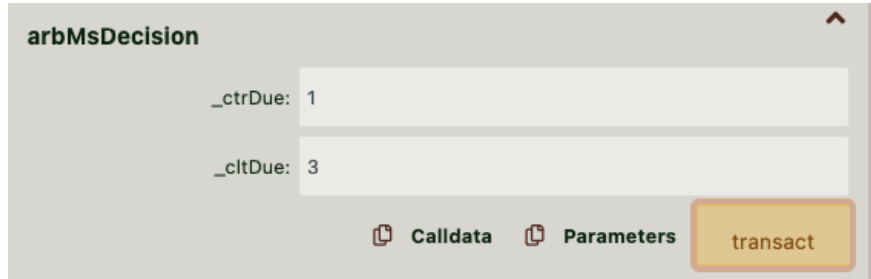
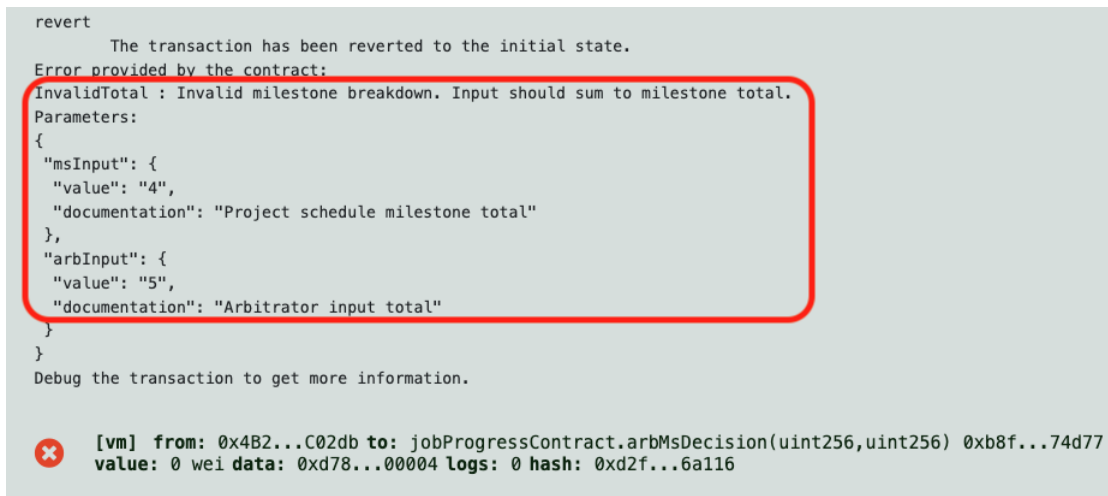


Figure 20: ARB decision (adapted from Fukuzawa (2024)).

The `arbMsDecision()` function also accounts for one type of error, whereby the ARB enters an incorrect MS total. In Figure 21, the ARB mistakenly accounts for five MS, and Remix displays an error. Note that this design does not prevent another type of accuracy error, e.g., awarding two MS to each party.



(a) ARB entry of MS award.



(b) Remix log error.

Figure 21: Incorrect MS entry (adapted from Fukuzawa (2024)).

After the ARB decision, the PC handles the actual payment. Calculation and payment are handled

separately. The `arbBreakout()` function determines the proportion of the deposit awarded to each party based on the outputs of the `arbMsDecision()` function. In this example, 25% of the deposit is awarded to the CTR for completing one MS, while the remaining 75% is returned to the CLT for the three incomplete MS. Figure 22 shows the log output of the arbitration payout determination. The amounts shown are the amounts in *wei* due to each party (e.g., 25% of the CLT deposit is 0.7825 ETH or 782,500,000 gwei). The actual transfer of funds is handled by the `arbPayout()` function.

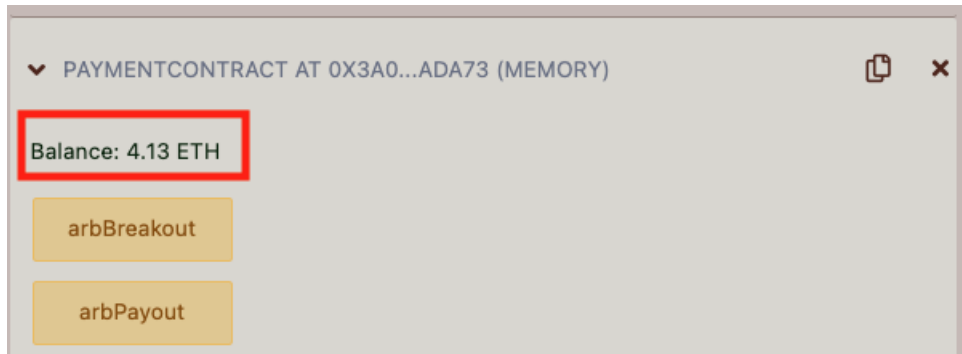
```

logs
[
  {
    "from": "0x3A09bB767270BADdFe534CD3cF830c14c65adA73",
    "topic":
    "0x9bfacf9100a57e94a0378e801e3419725936326f4100dc2ffe5b2f1a0f84580c",
    "event": "fundsDivide",
    "args": {
      "0": "CLT amount:",
      "1": "234750000000000000",
      "2": "CTR amount:",
      "3": "782500000000000000"
    }
  }
]

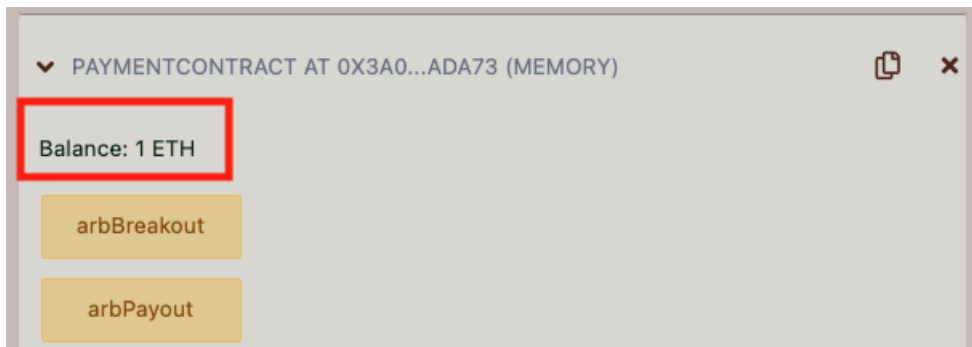
```

Figure 22: Event log from arbitration calculations (adapted from Fukuzawa (2024)).

Once again, we do not explore any handling of the CTR stake, so it remains in the contract balance until action is taken against it. Note the successful transfer of payment in Figure 23.



(a) PC balance pre-arbitration.



(b) PC balance post-arbitration.

Figure 23: Contract balance updates after arbitration (adapted from Fukuzawa (2024)).

5 Discussion

The two scenarios presented in this paper demonstrate the handling of conflict in a small-scale contracting job setup on a blockchain network. Internal resolution is available and desired, but we provide a means for 3P intervention if required. Ideally, the parties view this arbitration process as fair, reasonable, and quicker than current forced arbitration avenues. While all currency amounts used here are arbitrary, we assume that a 1% arbitration fee (potentially refundable) is acceptable by parties at the small scale. The 3P fee is collected separately in the AC (for simplicity and organization), which must be addressed before project payments are collected and work begins. Additionally, the time to resolution is shortened via the merging of arbitration into the blockchain process. Decisions can potentially be rendered and enforced in seconds rather than days, weeks, and months.

Continuing the assumption of lowest costs, since both parties want to minimize 3P costs, we view the mandatory arbitration fee as an incentive to resolve disputes internally. Additionally, given the negative stigmas associated with forced arbitration, we give parties the freedom to solve their own issues and impose an equal fee. The fee is low enough to seem reasonable, and it is refunded if the 3P service is not used. Crucial to the arbitration construct is the service provider for the contracting process; we assume that this agency has a well-managed process for vetting and selecting ARBs when required. The provider must make all attempts to deal with conflicts of interest to make this a service that parties view as acceptable and legitimate.

5.1 Scenario #1

The aim of the first scenario is to present the simplest case of conflict that invites 3P intervention. Both sides have a legitimate claim, and thus, the scenario is not overly tilted in favor of one side. The addition of an incomplete job status is meant to formalize a dispute (i.e., extending [Fukuzawa et al. \(2024\)](#)), and this is initiated with the `jobNotDone()` function. The CTR is given a choice to confirm or deny this dispute because we assume that neither party willingly wants to lose the 3P fee. In this manner, the CTR makes an explicit choice to resolve the dispute internally or hand the case to the ARB.

The internal resolution process is simulated with the comment process. Because this could be a remote transaction, the comment setup is a simple way to communicate issues. Without comments or some additional method to communicate, the parties would continue to rely on the digital image submission process. We do not intend to criticize the digital image process by itself, only to identify its limitations in aiding internal dispute resolution. Suppose that we rely solely on the image submission; the CTR may or may not provide additional proof. With the former case, the new proof is not guaranteed to address any or all of the CLT issues with job expectations. In the latter case, time and financial costs increase, and the lack of action could unintentionally lead to greater conflict.

If the CLT is still unsatisfied with progress after a round of internal dispute resolution, then no further internal communication is allowed; the process automatically heads to the ARB. This design is intentional for simplicity, but we admit that this may seem to invite the same forced arbitration that is presented negatively in Section 2. However, we ignore that aspect based on assumptions about participant behavior and motives as well as the overall process. First, parties enter this process willingly, understanding the terms, conditions, and structure. Second, parties can avoid arbitration by simply refusing to execute certain smart contract functions or by continuing with internal dispute resolution. Third, neither party is assumed to behave in a manner that is intentionally deceitful, i.e., there is no intentional delay or sabotage for the sole purpose of avoiding the 3P cost of arbitration. Finally, we assume that the 3P service is carefully managed to avoid bias, and *infinite looping* of internal resolution is not allowed.

5.2 Scenario #2

In the second scenario, we choose a pre-determined set of conditions and outcomes in order to demonstrate how arbitration can be applied in this blockchain setting if invoked. The arbitration decision is modeled after typical civil court outcomes both in and out of arbitration. For instance, in *Maraldo Asphalt v. Osgood Co.* ([McGregor, P.J., 1974](#)), a subcontractor was released from the contract prior to job completion; the trial court initially awarded damages in the amount of subcontractor expenditures. Thus, the contractor

received an amount proportional to the equity invested in the project. In *Gorden Sel-Way v. Spence Brothers, Inc.* (Boyle, J., 1991), a trial court amended an arbitration decision that included a financial interest payment. However, because the contract included an arbitration agreement that did not specify a limitation against interest, the trial court decision was reversed. Essentially, precedent exists for courts to honor an arbitration decision when the arbitrator acts within the scope of the contract terms. As applied to our design, the arbitration decision potentially determines settlement amounts; the parties agree to this setup upon initiation.

The greater detail including tasks and milestones is not only meant to provide structure to the process, but also to help with sequencing of events. This sequencing is key to blockchain’s ordered, chained nature for historical records. However, we only borrow a few elements from project management planning because the scope here is small. This design should generalize to larger projects with more complex scopes and work schedules.

Objectivity is introduced with the correlation between project completion and MS verification. In our demonstration, we equate 25% MS completion with 25% of funds earned. While the payments are divided equally among the MS in this example, this is for simplification and could be adjusted to meet the needs of the project (e.g., weighted cost distribution).

Structurally, the only reason for a constant set of times, MS, tasks, and payments is simplicity. The CLT and CTR can coordinate any number of divisions necessary to manage the project. Additionally, time is not necessarily a driving factor other than for the arbitration process. The time estimates for each task are non-binding, which provides flexibility during the verification process; the CLT can verify MS completion at any point in time. The CTR invokes an overall job timeline because we assume a history exists of performing similar jobs, and a CTR is likely to know a reasonable time estimate for job completion. Also, the time limit prevents a call to arbitration too early (e.g., insufficient time provided for CTR to complete project).

6 Conclusions and Future Work

Since the scenarios presented are drastically simplified for demonstration, there are limitations with this work. Similar to Fukuzawa et al. (2024), we find further work is needed to address code efficiency and dynamic cost conversions. However, we now address some specific aspects of this research.

With both scenarios, the inclusion of internal resolution is difficult to model other than by assumption. Further work is necessary to either demonstrate how this can be practically applied or provide greater tools to facilitate this process. The comment process introduced in the first scenario, for example, is not built to handle more detailed conversation or multiple iterations of debate.

Naturally, if we relax some assumptions about honesty and human behavior, then it is possible for parties to intentionally delay or subvert parts of the process. Furthermore, these types of deceit may be undetectable with the current setup, and further work is needed to address this assumption. An alternate form of monitoring, for example, is a potential avenue to explore.

The extent of possible arbitration decisions here is limited in scope. A more flexible adjudication process is not explored here, and the arbitrator is not allowed to act outside the bounds of the contract setup. Further research is needed to expand the arbitration scope. Additionally, with regard to the forms of binding arbitration that we employ here, nothing prevents either party from seeking litigation as a result of this process. This could, in turn, prove to be just as costly as current legal options.

With the second scenario specifically, there are several calculations involved with the handling of the deposit based on arbitration. Because these calculations are handled by the contract, numbers are kept simple to avoid issues with floating point figures. Further work is needed to export these calculations off-chain, which has numerous benefits: frees up on-chain storage, reduces operating costs and market concentration, and provides better data accuracy and greater decentralization (Cong et al., 2023).

Both scenarios are limited in scope and they lack the ability to dynamically adjust to changing external conditions. With an unforeseen weather delay, for example, parties cannot adjust the contracts to account for this type of condition. An effort to include greater flexibility for external challenges is needed.

Finally, we do not explore the likelihood or desire to adopt a new form of technology for general contracting. Fukuzawa et al. (2024) suggest that cost and buy-in will likely affect blockchain usage at the small scale, but the actual impacts on the users are unknown. This is not intended to be an exhaustive study of

blockchain adoption. However, some related research is ongoing within the construction industry that may have implications for smaller-scale industries. According to the World Economic Forum, the engineering and construction industries are slow to adopt new technology (due to time spent in research and development), so much so that growth has been stagnant for the past 50 years (Renz et al., 2016). Construction is beset with challenges from increased infrastructure demand as populations migrate into urban areas, an aging workforce, a greater desire for sustainable materials, and a lack of collaboration (*Building for the Future*, 2021). Users are most concerned with the uncertain return on investment (ROI) and high initial startup costs, while they appreciate long-term cost savings (Bademosi and Issa, 2021). Solar energy is a similar area where users complain about high upfront costs and industry stability, but are cautiously optimistic about the long-term savings (Semuels, 2024). Chen et al. (2023) identify several barriers to adopting newer forms of digital technology (DT) in construction: reliance on the status quo, lack of client interest, and lack of financial need. While parties are understandably cautious of the financial risks and uncertainties with implementing DTs, interestingly, providers see no utility in advocating DT if clients are not digital-ready (Chen et al., 2023). The implication for small-scale general contracting is that both CLT and CTR must know the technology, meaning that interest only increases if parties understand its benefits.

We also identify a few areas in which this concept can be expanded.

- **Conditions:** Expand this concept to include stricter conditions, e.g., time-based tasks and MS. Also, account for uncertainties and unplanned challenges such as weather delays and material shortages.
- **Scaling:** The project management principled scenario should generalize to larger projects with more resources. In addition to an MS schedule, a more complex work breakdown structure would separate the managerial levels of work from the technical levels (Kerzner, 2017). This WBS is key when the labor effort increases in the number of personnel as well as hierarchical divisions, e.g., sub-contracting. Furthermore, expensive projects at larger scale would invite an interim payment schedule, with payments submitted and transferred on a regular interval while work is performed.
- **History:** Expand the role of the assumed service provider. The service provider can manage performance history reviews to help CLT and CTR make informed decisions. Given the pessimism that already surrounds the fairness of arbitration from the consumer side, this small change could perhaps give the CLT confidence to utilize this business process system.
- **Expanded Services:** The ultimate endstate is an all-encompassing tool for parties to use that provides a cheaper option than the currently available methods for dispute resolution. Granted, as with any project with numerous variables, cost varies. However, one can expect that costs associated with traditional litigation stem from attorney fees, which are typically billed hourly (for smaller amounts) or via contingency (for larger amounts) at a one-third rate (Bieber, 2023a, Wallace Pierce Law, 2017). Hourly rates can typically reach several hundred dollars per hour (Bieber, 2023a). Arbitration costs are even more variable, depending on the type of case, arbitration service, number of arbitrators, and presence of counsel. In a case involving one of the national arbitration agencies such as AAA or JAMS, a consumer is likely to pay a filing fee of several hundred dollars; the arbitrator’s professional fee is usually split between negotiating parties or covered by the business or corporation (Fotohabadi, 2023). This professional fee can range from \$300 to \$1,200, depending on the arbitrator’s experience and expertise (Fotohabadi, 2023). Additionally, it is recommended that parties utilize attorneys for more complex arbitration cases, further driving up costs. However, in doing so, lawyers can increase the cost of discovery, which not only increases financial burdens for retaining counsel it also lengthens the arbitration process (Bannon et al., 2021, Fotohabadi, 2023).
- **Honesty:** Future work can address more egregious misbehavior, such as involving the CTR stake. In reality, the threat of financial penalties does not always deter people from committing dishonest acts. Future work can not only include a demonstration of a penalty against the stake but also a report of negative performance that exists on chain as a record (e.g., similar to a negative Google review). Another form of deterrence or monitoring may be required. Some insurance companies are already employing this type of monitoring with drones and satellites, albeit in a clandestine manner (Eaglesham, 2024).

References

- AAA (2023), ‘Costs of Arbitration’, American Arbitration Association. https://www.adr.org/sites/default/files/document_repository/AAA228-Costs_of_Arbitration.pdf (accessed 15 August 2023).
- Ahlemann, F., El Arbi, F., Kaiser, M. G. and Heck, A. (2013), ‘A process framework for theoretically grounded prescriptive research in the project management field’, *International Journal of Project Management* **31**(1), 43–56. <https://doi.org/10.1016/j.ijproman.2012.03.008>.
- Ahmadisheykhsarmast, S. and Sonmez, R. (2020), ‘A smart contract system for security of payment of construction contracts’, *Automation in Construction* **120**. <https://doi.org/10.1016/j.autcon.2020.103401>.
- Alair (2019), ‘Homeowners don’t trust contractors and we deserve it’, Alair Homes. <https://www.alairhomes.com/scottsdale/blog/homeowners-dont-trust-contractors-and-we-deserve-it/>.
- Angi (2021). <https://www.legal.angi.com/> (accessed 20 February 2024).
- Angi (2024). <https://www.angi.com/> (accessed 20 February 2024).
- Aouidef, Y., Ast, F. and Deffains, B. (2021), ‘Decentralized Justice: A Comparative Analysis of Blockchain Online Dispute Resolution Projects’, *Frontiers in Blockchain* **4**, 8. <https://doi.org/10.3389/fbloc.2021.564551>.
- Asgaonkar, A. and Krishnamachari, B. (2019), Solving the Buyer and Seller’s Dilemma: A Dual-Deposit Escrow Smart Contract for Provably Cheat-Proof Delivery and Payment for a Digital Good without a Trusted Mediator, in ‘2019 IEEE International Conference on Blockchain and Cryptocurrency (ICBC)’, IEEE, pp. 262–267. <https://ieeexplore.ieee.org/document/8751482>.
- Bademosi, F. and Issa, R. R. A. (2021), ‘Factors Influencing Adoption and Integration of Construction Robotics and Automation Technology in the US’, *Journal of Construction Engineering and Management* **147**(8), 13. [https://doi.org/10.1061/\(ASCE\)CO.1943-7862.0002103](https://doi.org/10.1061/(ASCE)CO.1943-7862.0002103).
- Bannon, P. J., Califano, A. S., Mooney, M. C. and Ayers-Mann, J. (2021), ‘Do Employment Arbitration Programs Reduce Legal Costs?’. <https://www.seyfarth.com/news-insights/do-employment-arbitration-programs-reduce-legal-costs.html> (accessed 16 February 2024).
- Bieber, C. (2023a), ‘How Much Do Lawyers Cost? 2023 Guide’. <https://www.forbes.com/advisor/legal/how-much-lawyers-cost/> (accessed 15 August 2023).
- Bieber, C. (2023b), ‘You’ll Never Guess How Many Americans Own Their Own Homes’, The Ascent. <https://www.fool.com/the-ascent/mortgages/articles/youll-never-guess-how-many-americans-own-their-own-homes/>, Accessed 20 March 2024.
- Bingham, L. B. (1997), ‘Employment arbitration: The repeat player effect’, *Employee Rights and Employment Policy Journal* **1**, 189. <https://ssrn.com/abstract=1324411>.
- Bland, P. and Ocamb, K. (2021), ‘Glenda Perez: ‘No one should have to go through what I went through’ with discriminatory forced arbitration’, Public Justice. <https://public-justice.medium.com/glenda-perez-no-one-should-have-to-go-through-what-i-went-through-with-discriminatory-forced-f9e90e6667db> (accessed 21 July 2023).
- Boyle, J. (1991), ‘Gordon Sel-Way v. Spence Bros’. <https://casetext.com/case/gordon-sel-way-v-spence-bros> 438 Mich. 488 (Mich. 1991) 475 N.W.2d 704 (accessed 20 January 2024).
- Buchwald, M. (2019), ‘Smart contract dispute resolution: The inescapable flaws of blockchain-based arbitration’, *Univ. of Pennsylvania Law Review* **168**(5), 1369–1423. https://scholarship.law.upenn.edu/penn_law_review/vol168/iss5/3.

- Building for the Future* (2021), Construction Sector Accord. <https://www.constructionaccord.nz/assets/Construction-Accord/files/building-for-the-future.pdf> New Zealand Ministry of Business, Innovation, & Employment (accessed 29 February 2024).
- CFPB (2015), ‘Arbitration Study: Report to Congress, pursuant to Dodd–Frank Wall Street Reform and Consumer Protection Act § 1028(a)’, Consumer Financial Protection Bureau. <https://www.consumerfinance.gov/data-research/research-reports/arbitration-study-report-to-congress-2015/> (accessed 13 January 2024).
- Chandrasekher, A. C. and Horton, D. (2019), ‘Arbitration Nation: Data from Four Providers’, *California Law Review* **107**(1), 1–66. <https://doi.org/10.15779/Z384F1MJ54>.
- Chen, X., Chang-Richards, A. Y., Yiu, T. W., Ling, F. Y. Y., Pelosi, A. and Yang, N. (2023), ‘A multivariate regression analysis of barriers to digital technologies adoption in the construction industry’, *Engineering, Construction and Architectural Management* **ahead-of-print**. <https://doi.org/10.1108/ECAM-11-2022-1051>.
- Cheung, K. (2019), ‘Escrowmyether’, EscrowMyEther. <http://escrowmyether.com/#readme> (accessed 21 July 2023).
- Cheung, S. O., Yiu, K. T. and Suen, H. (2004), ‘Construction Negotiation Online’, *Journal of Construction Engineering and Management* **130**(6), 844–852. [https://doi.org/10.1061/\(ASCE\)0733-9364\(2004\)130:6\(844\)](https://doi.org/10.1061/(ASCE)0733-9364(2004)130:6(844)).
- Cianci, M., Longo, A. J., Ward, D. V. and Iwry, J. (2024), ‘Litigation, Professional Perspective - Benefits & Risks of Decentralized Dispute Resolution’. <https://www.bloomberglaw.com/external/document/XA9GE5VS000000/litigation-professional-perspective-benefits-risks-of-decentrali> (accessed 13 January 2024).
- Colvin, A. J. (2011), ‘An Empirical Study of Employment Arbitration: Case Outcomes and Processes’, *Journal of Empirical Legal Studies* **8**(1), 1–23. <https://doi.org/10.1111/j.1740-1461.2010.01200.x>.
- Colvin, A. J. and Gough, M. D. (2023), ‘Mandatory Employment Arbitration’, *Annual Review of Law and Social Science* **19**(1), 131–144. <https://doi.org/10.1146/annurev-lawsocsci-120822-112007>.
- Cong, L. W., Hui, X., Tucker, C. and Zhou, L. (2023), ‘Scaling Smart Contracts via Layer-2 Technologies: Some Empirical Evidence’, *Management Science* **69**(12), 7306–7316. <https://doi.org/10.1287/mnsc.2023.00281>.
- Corkery, M. and Colvin, S. (2016), ‘Wells Fargo Killing Sham Account Suits by Using Arbitration’, New York Times. <https://www.nytimes.com/2016/12/06/business/dealbook/wells-fargo-killing-sham-account-suits-by-using-arbitration.html> (accessed 21 July 2023).
- Cowley, S. (2017), ‘Now Wells Fargo up to 3.5 million fraudulent accounts’, San Francisco Chronicle. <https://www.sfchronicle.com/business/article/Now-Wells-Fargo-up-to-3-5-million-fraudulent-12165170.php> (accessed 21 July 2023).
- Cutler, A. C. and Lark, D. (2022), ‘The hidden costs of law in the governance of global supply chains: the turn to arbitration’, *Review of International Political Economy* **29**(3), 719–748. <https://doi.org/10.1080/09692290.2020.1821748>.
- Das, M., Luo, H. and Cheng, J. C. (2020), ‘Securing interim payments in construction projects through a blockchain-based framework’, *Automation in Construction* **118**. <https://doi.org/10.1016/j.autcon.2020.103284>.
- Eaglesham, J. (2024), ‘Insurers Are Spying on Your Home From the Sky’. <https://www.wsj.com/real-estate/home-insurance-aerial-images-37a18b16> (accessed 8 April 2024).

- EPI (2017), ‘The average consumer in arbitration with Wells Fargo is ordered to pay the bank nearly \$11,000’, Economic Policy Institute. <https://www.epi.org/press/the-average-consumer-in-arbitration-with-wells-fargo-is-ordered-to-pay-the-bank-nearly-11000/> (accessed 21 July 2023).
- Farmer, M. B. (2012), ‘Mandatory and Fair? A Better System of Mandatory Arbitration’, *Yale Law Journal* **121**(8), 2346. <https://www.jstor.org/stable/41510479>.
- Federal Reserve (2022), ‘Economic Well-Being of U.S. Households (SHED)’, Federal Reserve Board of Governors. <https://www.federalreserve.gov/publications/2022-economic-well-being-of-us-households-in-2021-housing.htm>, Accessed 20 March 2024.
- Fotohabadi, M. (2023), ‘How Much Does Arbitration Cost?’. <https://www.adrtimes.com/how-much-does-arbitration-cost/> (accessed 16 February 2024).
- Fukuzawa, M. B. (2024), Applications of Smart Contracts in Competitive and Cooperative Environments, PhD dissertation, North Carolina State University, Raleigh, NC. <https://www.lib.ncsu.edu/resolver/1840.20/41663>.
- Fukuzawa, M. B., McConnell, B. M., Kay, M. G., Thoney-Barletta, K. A. and Warsing, D. P. (2024), ‘Implementing a letter of credit style business process for small-scale contracting using smart contracts’. Working paper in peer review. <https://doi.org/10.31224/3847>.
- Ghodoosi, F. and Sharif, M. M. (2021), ‘Justice in arbitration: the consumer perspective’, *International Journal of Conflict Management* **32**(4), 626–647. <https://doi.org/10.1108/IJCM-10-2019-0203>.
- Ghodoosi, F. and Sharif, M. M. (2023), ‘Arbitration Effect’, *American Business Law Journal* **60**(2), 235–287. <https://doi.org/10.1111/ablj.12222>.
- Goharshady, A. K. (2021), Irrationality, Extortion, or Trusted Third-Parties: Why it is Impossible to Buy and Sell Physical Goods Securely on the Blockchain, in ‘2021 IEEE International Conference on Blockchain (Blockchain)’, IEEE, pp. 73–81. [10.1109/Blockchain53845.2021.00021](https://doi.org/10.1109/Blockchain53845.2021.00021).
- Goldenfein, J. and Leiter, A. (2018), ‘Legal Engineering on the Blockchain: ‘Smart contracts’ as Legal Conduct’, *Law and Critique* **29**(2), 141–149. <https://doi.org/10.1007/s10978-018-9224-0>.
- Goldfeder, S., Bonneau, J., Gennaro, R. and Narayanan, A. (2017), Escrow protocols for cryptocurrencies: How to buy physical goods using bitcoin, in A. Kiayias, ed., ‘Financial Cryptography and Data Security: 21st International Conference, FC 2017, Sliema, Malta, April 3-7, 2017, Revised Selected Papers 21’, Springer, pp. 321–339. https://doi.org/10.1007/978-3-319-70972-7_18.
- Hayes, A. (2022), ‘Signing Away Your Rights: Forced Arbitration—Overcoming Corporate “Get Out Jail Free Cards” and Finding Avenues for Justice’, *The [F]law*. <https://theflaw.org/articles/signing-away-your-rights-forced-arbitration-overcoming-get-out-of-jail-free-cards-and-finding-avenues-for-justice/> (accessed 21 July 2023).
- Hershkoff, H. and Norris, L. (2023), ‘The Oligarchic Courthouse: Jurisdiction, Corporate Power, and Democratic Decline’, *Michigan Law Review* **122**(1), 1–54. <https://doi.org/10.36644/mlr.122.1.oligarchic>.
- Hiltzik, M. (2017), ‘No surprise: Wells Fargo is leveraging its arbitration clause to win an advantageous scandal settlements’, *Los Angeles Times*. <https://www.latimes.com/business/hiltzik/la-fi-hiltzik-wells-settlement-20170331-story.html> (accessed 21 July 2023).
- JAMS (2023), ‘Arbitration Defined: What is Arbitration?’, JAMS Arbitration Services. <https://www.jamsadr.com/arbitration-defined/> (accessed 15 August 2023).
- Johnston, J. S. and Zywicki, T. (2016), ‘The Consumer Financial Protection Bureau’s Arbitration Study: A Summary and Critique’, *Banking & Financial Services Policy Report* **35**(5), 9–33. <https://www.proquest.com/trade-journals/consumer-financial-protection-bureaus-arbitration/docview/1791368655/se-2>.

- Kerzner, H. (2017), *Project Management - A Systems Approach to Planning, Scheduling, and Controlling (12th Edition)*, John Wiley & Sons. <https://app.knovel.com/hotlink/toc/id:kpPMASAPSC/project-management-systems/project-management-systems>.
- Kleros (2024), ‘The Justice Protocol’. <https://kleros.io/> (accessed 13 January 2024).
- Koren, J. R. (2017), ‘Wells Fargo’s \$110-million settlement is still not enough, lawyers say’, *Los Angeles Times*. <https://www.latimes.com/business/la-fi-wells-settlement-opponents-20170329-story.html> (accessed 21 July 2023).
- Level Playing Field (2017), ‘Wells Fargo and forced consumer arbitration’. <http://fairarbitrationnow.org/wp-content/uploads/LPF-Wells-Fargo-Report-September-2017-Update.pdf> (accessed 21 July 2023).
- Li, W., Duan, P. and Su, J. (2021), ‘The effectiveness of project management construction with data mining and blockchain consensus’, *Journal of Ambient Intelligence and Humanized Computing* pp. 1–10. <https://doi.org/10.1007/s12652-020-02668-7>.
- Liu, K.-C. (2023), ‘Guaranteeing the Right to a Fair Trial in IP-Related Arbitration—In Germany Perhaps? And Elsewhere?’, *IIC-International Review of Intellectual Property and Competition Law* **54**(8), 1244–1260. <https://doi.org/10.1007/s40319-023-01316-9>.
- LocalCryptos (2023). <https://localcryptos.com/> (accessed 21 July 2023).
- Lu, L. (2023), ‘Evaluation on the application mode of blockchain technology in water transportation engineering project management’, *Water Supply* **23**(10), 4272–4285. <https://doi.org/10.2166/ws.2023.255>.
- Mahony, D. M., Klaas, B. S., McClendon, J. A. and Varma, A. (2005), ‘The Effects of Mandatory Employment Arbitration Systems on Applicants’ Attraction to Organizations’, *Human Resource Management* **44**(4), 449–470. <https://doi.org/10.1002/hrm.20084>.
- McGregor, P.J. (1974), ‘Maraldo Asphalt v. Osgood Co.’. <https://casetext.com/case/maraldo-asphalt-v-osgood-co> 53 Mich. App. 324, 220 N.W.2d 50, Mich. Ct. App. 1974 (accessed 20 January 2024).
- Meng, H., Bian, E. and Tang, C. (2019), Themis: Towards Decentralized Escrow of Cryptocurrencies without Trusted Third Parties, in ‘2019 Sixth International Conference on Software Defined Systems (SDS)’, IEEE, pp. 266–271. [10.1109/SDS.2019.8768704](https://doi.org/10.1109/SDS.2019.8768704).
- Meng, Q. and Sun, R. (2021), ‘Towards Secure and Efficient Scientific Research Project Management Using Consortium Blockchain’, *Journal of Signal Processing Systems* **93**, 323–332. <https://doi.org/10.1007/s11265-020-01529-y>.
- NCJB (2023a), ‘Arbitration and Mediation’, North Carolina Judicial Branch. <https://www.nccourts.gov/help-topics/lawsuits-and-small-claims/arbitration-and-mediation> (accessed 15 August 2023).
- NCJB (2023b), ‘Small Claims’, North Carolina Judicial Branch. <https://www.nccourts.gov/help-topics/lawsuits-and-small-claims/small-claims> (accessed 15 August 2023).
- NCLBGC (2023), ‘FAQ for Consumers’, North Carolina Licensing Board for General Contractors. <https://nclbgc.org/faq-consumers/>, Accessed 22 March 2024.
- Ojiako, U., Chipulu, M., Marshall, A. and Williams, T. (2018), ‘An examination of the ‘rule of law’ and ‘justice’ implications in online dispute resolution in construction projects’, *International Journal of Project Management* **36**(2), 301–316. <https://doi.org/10.1016/j.ijproman.2017.10.002>.
- Ortolani, P. (2019), ‘The impact of blockchain technologies and smart contracts on dispute resolution: arbitration and court litigation at the crossroads’, *Uniform Law Review* **24**(2), 430–448. <https://doi.org/10.1093/ulr/unz017>.

- Renz, A., Solas, M. Z., Rodrigues de Almeida, P., Bühler, M., Gerbert, P., Castagnino, S. and Rothballer, C. (2016), ‘Shaping the Future of Construction: A Breakthrough in Mindset and Technology’. <https://www.weforum.org/publications/shaping-the-future-of-construction-a-breakthrough-in-mindset-and-technology/> (accessed 29 February 2024).
- Saygili, M., Mert, I. E. and Tokdemir, O. B. (2022), ‘A decentralized structure to reduce and resolve construction disputes in a hybrid blockchain network’, *Automation in Construction* **134**, 104056. <https://doi.org/10.1016/j.autcon.2021.104056>.
- Schwartz, D. S. (2008), ‘Mandatory Arbitration and Fairness’, *Notre Dame Law Review* **84**(3), 1247–1341.
- Schwartz, D. S. (2012), ‘Claim-Suppressing Arbitration: The New Rules’, *Indiana Law Journal* **87**(1), 239–270. <https://www.repository.law.indiana.edu/ilj/vol87/iss1/15/>.
- Schwartzbach, N. I. (2021), An Incentive-Compatible Smart Contract for Decentralized Commerce, in ‘2021 IEEE International Conference on Blockchain and Cryptocurrency (ICBC)’, IEEE, pp. 1–3. [10.1109/ICBC51069.2021.9461077](https://doi.org/10.1109/ICBC51069.2021.9461077).
- Samuels, A. (2024), ‘The Rooftop Solar Industry Could Be on the Verge of Collapse’, Time. <https://time.com/6565415/rooftop-solar-industry-collapse/> (accessed 29 February 2024).
- Sharma, V., Oyebode, O. J., Uniyal, V., Rajyalaxmi, M., Al-Tae, M. and Alazzam, M. B. (2023), Technical use of Smart Contracts in Blockchain-Based Project Management, in ‘2023 3rd International Conference on Advance Computing and Innovative Technologies in Engineering (ICACITE)’, IEEE, pp. 272–276. <https://doi.org/10.1109/ICACITE57410.2023.10182588>.
- Sherwyn, D., Estreicher, S. and Heise, M. (2005), ‘Assessing the Case for Employment Arbitration: A New Path for Empirical Research’, *Stanford Law Review* **57**(5), 1557–1591. <https://www.jstor.org/stable/40040226>.
- Shierholz, H. (2017a), ‘Correcting the record: Consumers fare better under class actions than arbitration’, Economic Policy Institute. <https://www.epi.org/publication/correcting-the-record-consumers-fare-better-under-class-actions-than-arbitration/> (accessed 21 July 2023).
- Shierholz, H. (2017b), ‘Forced arbitration is bad for consumers’, Economic Policy Institute. <https://www.epi.org/publication/forced-arbitration-is-bad-for-consumers/> (accessed 21 July 2023).
- Sonmez, R., Sönmez, F. Ö. and Ahmadisheykhsarmast, S. (2021), ‘Blockchain in project management: a systematic review of use cases and a design decision framework’, *Journal of Ambient Intelligence and Humanized Computing* **14**(7), 1–15. <https://doi.org/10.1007/s12652-021-03610-1>.
- Staszak, S. (2019), ‘In the Shadow of Litigation: Arbitration and Medical Malpractice Reform’, *Journal of Health Politics, Policy and Law* **44**(2), 267–301. <https://doi.org/10.1215/03616878-7277380>.
- Stipanowich, T. J. (1988), ‘Rethinking American Arbitration’, *Indiana Law Journal* **63**(3), 425–487. <https://www.repository.law.indiana.edu/cgi/viewcontent.cgi?referer=&httpsredir=1&article=1115&context=ilj>.
- Stone, K. and Colvin, A. (2015), ‘The arbitration epidemic: Mandatory arbitration deprives workers and consumers of their rights’, Economic Policy Institute. https://www.epi.org/publication/the-arbitration-epidemic/#_ref66 (accessed 21 July 2023).
- Stuart James (2019), ‘3 Things to Know About Becoming a Kleros Juror’. <https://blog.kleros.io/become-a-juror-blockchain-dispute-resolution-on-ethereum/> (accessed 13 January 2024).
- Thumbtack (2024). <https://www.thumbtack.com/> (accessed 22 March 2024).
- University of Missouri (2015), ‘How much does arbitration cost? And, Who pays for it?’, University of Missouri School of Law. <https://law.missouri.edu/arbitrationinfo/2015/10/11/how-much-does-arbitration-cost/> (accessed 15 August 2023).

- Ustun, E. S. and Yuce, M. (2022), Smart Legal Contracts & Smarter Dispute Resolution, in ‘2022 IEEE 24th Conference on Business Informatics (CBI)’, Vol. 2, IEEE, pp. 111–117. <https://doi.org/10.1109/CBI54897.2022.10056>.
- Viktorov, K. and Hollands, K. (2018), ‘White Paper for project EscrowBlock’, EscrowBlock. <https://escrowblock.net/assets/docs/EscrowBlock.White.Paper.EN.pdf> (accessed 21 July 2023).
- Wallace Pierce Law (2017), ‘Different Types of Attorney’s Fees in North Carolina’. <https://www.wallacepierce.com/firm-news/2017/february/different-types-of-attorney-s-fees-in-north-caro/> (accessed 16 February 2024).
- White, A. M. and Mansfield, C. L. (2002), ‘Literacy and contract’, *Stanford Law & Policy Review* **13**(2), 233. <https://heinonline.org/HOL/LandingPage?handle=hein.journals/stanlp13&div=26&id=&page=>.
- Xue, J. H. and Holz, R. (2019), Applying smart contracts in online dispute resolutions on a large scale and its regulatory implications, in M. Ragnedda and G. Destefanis, eds, ‘Blockchain and Web 3.0 : Social, Economic, and Technological Challenges’, Taylor & Francis Group, pp. 177–191. <https://doi.org/10.4324/9780429029530-12>.
- Zhao, R., Chen, Z. and Xue, F. (2023), ‘A blockchain 3.0 paradigm for digital twins in construction project management’, *Automation in Construction* **145**, 104645. <https://doi.org/10.1016/j.autcon.2022.104645>.
- Zhuk, A. (2023), ‘Applying blockchain to the modern legal system: Kleros as a decentralised dispute resolution system’, *International Cybersecurity Law Review* **4**(3), 351–364. <https://doi.org/10.1365/s43439-023-00086-x>.
- Zimbeck, D. (2014), ‘Two Party double deposit trustless escrow in cryptographic networks and bitcoin’, BitHalo. <https://cryptochainuni.com/wp-content/uploads/BitHalo-whitepaper-two-party-double-deposit-trustless-escrow-in-cryptographic-networks-bitcoin.pdf>, Accessed 21 July 2023.

A Acronyms

Table 4: Acronyms used in this paper.

AAA	American Arbitration Association
AC	Arbitration Contract
ADR	Alternative Dispute Resolution
AI	Artificial Intelligence
ARB	Arbitrator
BIM	Building Information Modeling
CFPB	Consumer Financial Protection Bureau
CLT	Client
CTR	Contractor
DCENTR	Decentralized Constructing Enabling Transparent Resolution
DCR	Distributed Conflict Resolution
DDR	Decentralized Dispute Resolution
DJ	Distributed (Decentralized) Justice
DoS	Denial-of-Service
DR	Dispute Resolution
DT	Digital Technology
ETH	Ether
FAA	Federal Arbitration Act
IDE	Integrated Development Environment
JAMS	Judicial Arbitration and Mediation Services, Inc.
JPC	Job Progress Contract
JUS-DCENTR	Justice-Decentralized Constructing Enabling Transparent Resolution
MS	Milestone
OCDRM	On-chain Dispute Resolution Mechanisms
ODR	Online Dispute Resolution
PC	Payment Contract
PP	Partial Payment
PSC	Project Schedule Contract
ROI	Return On Investment
SoWC	Scope of Work Contract
3P	Third-party
USD	United States Dollar
WBS	Work Breakdown Structure