

X-57 Power and Command System Design

Sean Clarke, P.E., Matthew Redifer,
Kurt Papathakis, and Aamod Samuel
NASA Armstrong Flight Research Center
Edwards, California, USA
Sean.Clarke@nasa.gov

Trevor Foster
Empirical Systems Aerospace, Inc.
San Luis Obispo, California, USA
Trevor.Foster@ESAero.com

Abstract—This paper describes the power and command system architecture of the X-57 *Maxwell* flight demonstrator aircraft. The X-57 is an experimental aircraft designed to demonstrate radically improved aircraft efficiency with a 3.5 times aero-propulsive efficiency gain at a “high-speed cruise” flight condition for comparable general aviation aircraft. These gains are enabled by integrating the design of a new, optimized wing and a new electric propulsion system. As a result, the X-57 vehicle takes advantage of the new capabilities afforded by electric motors as primary propulsors. Integrating new technologies into critical systems in experimental aircraft poses unique challenges that require careful design considerations across the entire vehicle system, such as qualification of new propulsors (motors, in the case of the X-57 aircraft), compatibility of existing systems with a new electric power distribution bus, and instrumentation and monitoring of newly qualified propulsion system devices.

Keywords—aircraft propulsion and power, electric propulsion, experimental aircraft, failure modes and effects analysis, x-plane

I. INTRODUCTION

The National Aeronautics and Space Administration (NASA) Scalable Convergent Electric Propulsion and Operations Research (SCEPTOR) project is demonstrating radically improved aircraft efficiencies with the X-57 *Maxwell* flight demonstrator aircraft. In order to achieve the 3.5 times aero-propulsive efficiencies, a Tecnam P2006T (Costruzioni Aeronautiche Tecnam S.r.l., Capua, Italy) airframe was chosen as the baseline aircraft. The aircraft will be retrofitted with a high aspect-ratio wing, the internal combustion engines will be replaced with electric motors and relocated to the wingtips, an array of smaller electric motors and propellers will be integrated into the leading edge of the wing, and the fuel tanks will replace with batteries (see Fig. 1). The X-57 flight demonstrator aircraft was designed using propulsion airframe integration (PAI) techniques that have long interested aircraft designers but were heretofore impractical due to the limitations of more traditional propulsion systems. For example, turbine and piston engines designed for the small scales required for these PAI opportunities cannot achieve specific power and efficiency as high as can larger systems. This condition reduces the gains achieved from PAI when using traditional, hydrocarbon-based powertrains. Improvements in the performance of electric propulsion powertrains make these PAI techniques practical, enabling an overall improvement of aircraft energy usage and, therefore, operating costs.

Integrated design for effective interaction between the wing and the propellers is the core demonstration effort on the X-57 flight demonstrator aircraft; recent advancements in

high-performance electric motors, motor controllers, and battery management technologies enable this new design paradigm. The X-57 will be the first electrified X-plane and because of the electric powertrain that is central to the capability being demonstrated here, the aircraft has been designated *Maxwell* in honor of James Clerk Maxwell’s foundational work describing the nature of the electromagnetic forces that are harnessed in the electric motors, motor inverters, power buses and batteries that comprise the X-57 traction system.

II. SCOPE

This paper describes the design of the X-57 avionics power, traction power, and command systems for optimized system reliability given the constraints of a flight research program showcasing experimental hardware in critical systems. The system architecture relies on redundancy throughout the design to limit the scope of failures, component testing to limit the likelihood of failures, and failure analysis and training to limit the persistence of failures. Design decisions throughout the development of the X-57 traction system have been based on these principles and may serve as a case study for development of future experimental aircraft and potential commercial aircraft exhibiting these technologies. Power and command system redundancy is a key feature for limiting the impact of faults along the command and data handling pathways, the traction power buses, the energy storage medium, and the main vehicle motors. Evaluation of each developmental component by way of component independent design review, endurance testing, and function validation in the integrated system are essential to ensuring reliability. The integrated X-57 system design will be evaluated for failure modes and will be integrated into an aircraft simulator with a flight-like cockpit that will be used for pilot training, ensuring rapid response to the most severe fault cases.

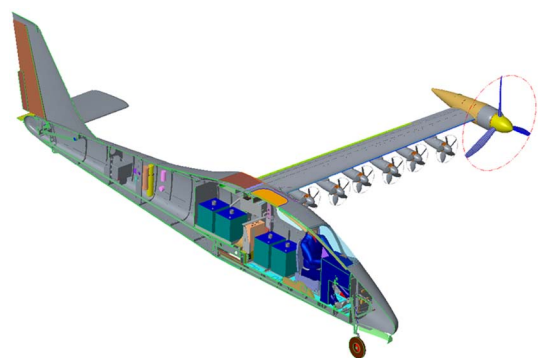

Fig. 1. X-57 Isometric model with centerline cut, showing battery system, high aspect ratio wing, electric motors, and traction power bus.

III. SYSTEM DESIGN OVERVIEW

Development of the X-57 research systems has been staged into four configurations (Mods I-IV), each of which increases in complexity over the course of the research program. This approach enables researchers to evaluate the baseline performance and handling qualities of the unmodified aircraft in Mod I, the experimental propulsion system dynamics and reliability in Mod II, the high-performance, high aspect-ratio wing in Mod III, and the distributed electric propulsion system in Mod IV. By deploying the traction power, avionics power, and command systems in Mod II, the integrated system performance of these systems can be studied in a flight-proven airframe configuration with ample rudder authority and flexible center of gravity (CG) placement. Thus, by the time the PAI features are being evaluated in Mod III and Mod IV, the electrical systems will be well understood and reliable as a result of the extensive experience gained operating the traction power, avionics power, and command systems during the Mod II ground- and flight-testing program.

The X-57 traction system beginning in Mod II consists of two independent battery packs, redundant power distribution buses, and two cruise motors. Each cruise motor is rated for 255 Nm and up to 2700 rpm (72 kW), shown in Fig. 2, and powered by two independent motor torque controllers which convert the DC power provided by the batteries to switched AC power based on the torque commanded by the pilot. Details of the cruise motor design and development process are described in [1] and [2]. The battery packs are a custom design that uses commercial off-the-shelf (COTS) lithium-ion 18650 cells arranged into four large (approximately 100 lb.) modules per pack. Each of the two battery packs supply approximately 23 kWh of usable capacity and operate independently from each other. In the event of a failure in one of the redundant systems, either pack can each provide sufficient power for a controlled return to base.

Redundancy throughout the design of the traction power, avionics power, and command system is a critical tool for ensuring minimum required thrust is available in the event of any single fault condition on this experimental flight demonstrator. Fig. 3 shows how the traction power system redundancy approach has been used to design for two independent vehicle batteries, traction buses, and motor torque controllers for the main cruise motors. This approach is critical

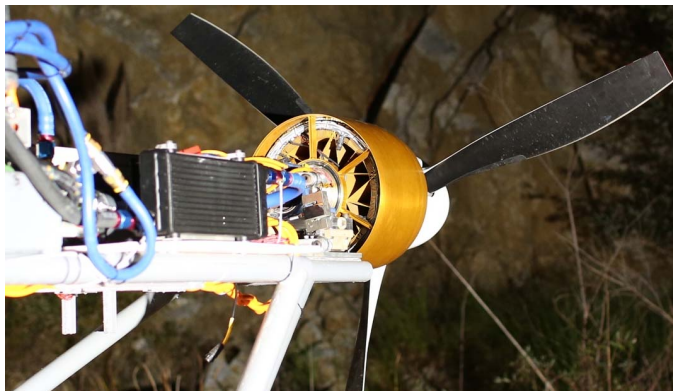

Fig. 2. The X-57 Cruise Motor prototype and variable-pitch propeller before a test run. Photograph credit Joby Aviation.

for the X-57 design because the cruise power system is located at the wingtips in order to achieve improved propulsive efficiency. Nominally, this wingtip configuration provides much improved performance of the main propellers, but this configuration also increases the complexity of designing for the single-motor-out failure case because a failure of one of the cruise motors or propellers introduces a large yaw moment due to asymmetric thrust. The redundancy approach of each of the systems described in this paper limits the majority of those failure cases to compromising less than 50 percent of the available thrust at either cruise motor. Similarly, for the Mod IV Distributed Electric Propulsion (DEP) system driving 12 propellers along the leading edge of the wing (six on each side) to achieve high lift at low airspeeds, a redundant architecture is critical to reducing the severity of single-failure modes. Asymmetry in the induced velocity of air across the left wing versus the right wing can cause roll or yaw of the aircraft and a resultant loss of lift. The redundancy approach limits the effects of these failures to primarily avoid asymmetric upsets, and secondarily to limit the magnitude of the failure to no more than three of the propulsors for most cases (because no more than three of the motors in the DEP system on each side of the wing share a bus).

The traction and command systems developed for the X-57 aircraft are intentionally kept as simple as possible to minimize the development risks associated with complex systems and to simplify testing and integration. Most of the components are COTS products or are slightly modified from COTS products. Although the goal is to use parts that are of high technology readiness level (TRL) and already available in the marketplace, some such items are not suitable because of the demanding performance requirements for the X-57 or because of specific application needs. The cruise motors and torque controllers are being developed for this vehicle by Joby Aviation (Santa Cruz, California). The main vehicle battery system is being developed by Electric Power Systems Inc. (Industry, California). The X-57 acceptance and qualification test plan is designed to screen each component with a level of investigation appropriate to identifying manufacturing defects and design flaws before integration into the X-57.

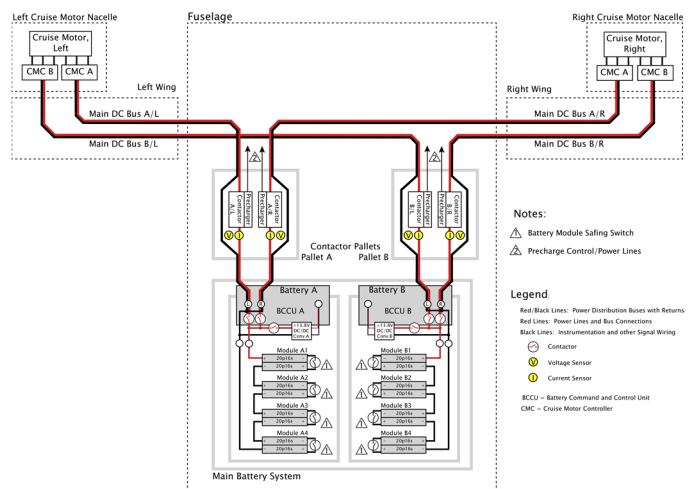

Fig. 3. X-57 Redundant Traction Power System.

IV. AVIONICS POWER SYSTEM

The X-57 avionics power system is designed to provide a piloting experience similar to that of the Tecnam P2006T, the aircraft from which the X-57 flight demonstrator is derived. The approach to the design involves maintaining as many of the existing avionics systems as possible, allowing, to the extent safely possible, the use of established procedures identified in the relevant Pilot Operating Handbook. The stock configuration follows the approach of many twin engine aircraft by cross-strapping the engine generator buses to a main bus which is backed up by a battery. This method allows the operation of essential aircraft avionics systems such as instruments, landing gear, and flaps in the event of many types of system power loss. The avionics power buses can be powered from either the left or right generator buses, or the battery backup. Loads can be shed by opening the cross-strap switches or the left and right avionics buses, affording the pilot many options in the event of various avionics power system failures.

The X-57 flight demonstrator follows the same approach, maintaining many of the existing switches, wiring, circuit breakers, and relays of the Tecnam P2006T. As shown in the X-57 avionics power system interconnect (Fig. 4), the left and right generator buses are fed by the aircraft traction battery system. The traction battery consists of two battery packs (A and B). Because the battery packs have a nominal voltage of 461 VDC, the traction battery system implements two DC/DC buck converters (one for each battery pack) to generate 14 VDC avionics power which feeds the left and right generator buses from the A and B batteries, respectively. Each buck converter is sized for the entire avionics bus load. The stock aircraft backup battery remains connected to the essential bus to provide essential avionics power in the event of a traction battery failure or shutdown. Avionics power can also be supplied from the aircraft external power socket for ground-testing operations.

Notable differences between the Tecnam P2006T and the X-57 flight demonstrator are the instrumentation bus and the new wing avionics buses. The instrumentation bus is fed from the aircraft right generator bus by way of a DC/DC boost converter in order to generate 28 VDC used for instrumentation. The wing avionics buses A and B are added to facilitate the redundancy in the cruise motors. The dual core windings in the cruise motor are nominally powered by two separate cruise motor controllers. Each wing avionics bus provides power to the cruise controllers in the left or right wing. Each motor controller in the left and right wings is fed by the A and B battery pack separately via the wing avionics buses, allowing shutdown or failure of either individual battery or wing avionics bus with continued operation of the motor at reduced power with one remaining controller.

To effectively communicate warnings to the pilot about faults in the new avionics power and traction power systems, the Tecnam P2006T annunciator panel was customized. The new annunciator panel configuration, is shown in Fig. 5. The A and B avionics warning lights are triggered by a fault indication from the DC/DC buck converters in the traction battery system. A typical response to this warning would be to shut down the avionics side with the fault, and continue operations on the opposite side. A low-voltage indication from either of the main

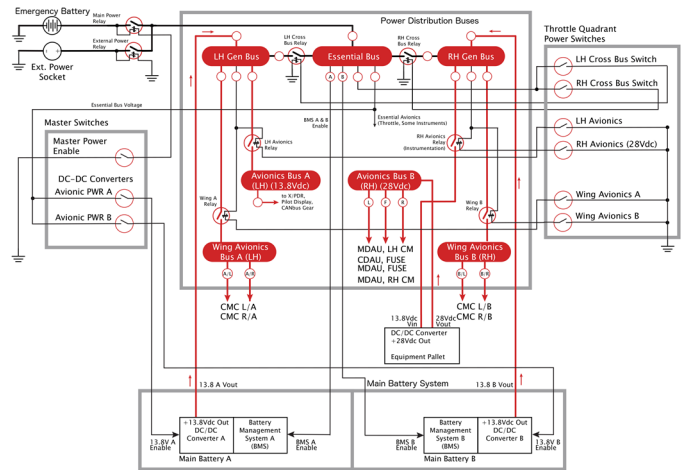

Fig. 4. The X-57 avionics power system interconnect.

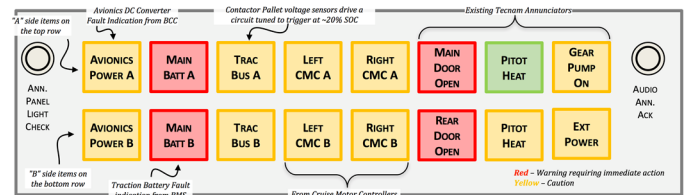

Fig. 5. The X-57 annunciator panel with electric propulsion indication.

traction battery sides is considered a critical fault. Depending on other factors, the response may be the shutdown of the offending battery side and immediate return to base with reduced motor performance. These annunciator panel warnings are in addition to other warnings that are part of the command bus system, including fault notification via the multi-function display and audio alarms.

V. TRACTION POWER SYSTEM

The X-57 traction power system is designed to safely and reliably provide power to the motor torque controllers and ensure that enough power would remain available to safely land the aircraft in the event of single-point failures. This is achieved by using redundant power buses, physical separation of cabling and conduits, and electronically controlled power contactors for safe operation of the motor controllers.

While definitive guidelines exist for designing a safe and reliable traction power system, certified, airworthy electric aircraft propulsion systems for manned flight are a relatively new design space. There is little precedent or documentation to define proper standards. Existing Federal Aviation Regulations (FARs), such as Part 23 and Part 25, or Aeronautical Radio, Incorporated (ARINC) 400 series standards provide only basic wiring standards and limited guidance can be inferred from turbine or gas engine regulations. Designing the X-57 traction power system necessitated evaluating the system as a whole to implement standard aircraft features and capabilities. Once a functional system was developed, the available standards were combined with best practices to implement each subsystem.

One such subsystem is the traction power cabling which includes standard aircraft features such as redundancy and isolation. The Mod II/III traction power bus for the X-57 is

divided into two independent A and B buses that are each subdivided between the left (A/L and B/L) and right (A/R and B/R) side of the aircraft, as shown in Fig. 3. Each bus (A and B) is independently powered by an electrically-isolated battery. This architecture provides redundancy to the cruise motors in the event one of the buses fails. The buses are additionally isolated from each other, within the wing, each bus running inside dedicated conduits. This isolation aids in preventing cascading bus failures. Driving each cruise motor are two motor torque controllers, commonly referred to as the cruise motor controller (CMC). Each bus feeds one of the CMCs for one cruise motor. This technique follows the same redundant design philosophy that given any single-point failure, each cruise motor can still operate under the command of a single CMC.

Contactors pallets are installed in the traction bus cabling between the batteries and the motors. There are two contactor pallets (A and B) located in the fuselage of the aircraft corresponding to the associated A or B bus. Each pallet contains sensors and electrical components to complete or interrupt the circuit to the motor controllers. To safely power on the CMCs and avoid inadvertently energizing the traction bus in the wing, custom pre-chargers with integrated, aircraft-grade contactors are used on the pallets. The pre-chargers control the voltage in the traction bus to restrict the inrush current and the contactors allow remote switching of the power from the traction bus. Current and voltage sensors within each pallet are used to measure the total energy consumption rate and total energy consumed. Isolation of the A and B buses is maintained with two contactor pallets physically placed on separate sides of the aircraft. This arrangement prevents failure of components within one pallet from cascading to the other pallet.

The wire used for the X-57 traction bus cable is unique in that it is custom designed to address several challenges. Minimizing weight is inherently important, so using small-gauge wire is necessary. Wire that is too small, however, is a safety concern because of the potential for wires to overheat. Each electric cruise motor is designed to run at a total power of 60 kW with each CMC nominally drawing 30 kW. The design of the X-57 batteries calls for lithium-ion cells in a series/parallel configuration combined with a depth-of-discharge limitation that drives the voltage range between 416 VDC and 525 VDC. To size the traction cable, we assume that each bus (A/L, A/R, B/L, B/R) must carry 30 kW, which results in a current ranging from 57 A to 72 A for each bus. Derating factors for altitude and number of conductors in a bundle are determined using [3] which relates wire size (in American wire gauge, AWG) to the expected temperature rise. The X-57 design uses four flat 10-AWG conductors that are equivalent to 4-AWG as shown in Fig. 6. These current limits only allow 4-AWG if the cable is able to reject heat to ambient air. If the air temperature is allowed to rise due to high-current operation of the wire, the 4-AWG wire may fail. In this design example, aerospace standards do exist, however, those standards fail to take into account considerations from a systems perspective. This standard provides a good first approximation, but model-driven engineering (MDE) can refine the design further. Initial application of the SAE standard estimated that 2-AWG would be required for nominal operation. Additionally, it is possible to over-drive the CMC in response to some system failures, which

would require pulling more than the nominal design current through a single bus. In this case, the SAE standard estimates that 2-AWG is required. Taking the MDE approach, a specialized 4-AWG cable with a high-temperature jacket was selected. The traction bus conduits are fabricated from a thermally-conductive composite material and are thermally isolated from the wing structure. In practice, the time spent operating at elevated temperatures will be monitored and limited as needed to prevent damage to the traction bus. Tests on the traction bus cable with X-57 flight profiles are being conducted using the NASA Electric Aircraft Testbed (NEAT) at the NASA Glenn Research Center (Cleveland, Ohio) in order to better quantify the performance of the cable.

Radiated electromagnetic interference (EMI) from the traction bus is an additional design challenge, and can interfere with other systems on the vehicle. The traction system may exhibit high frequency interference due to inverter switching events or lower frequency noise related to motor field rotation. To mitigate this, several traditional shielding methods were considered, but the custom wing in the Mod III configuration has very limited space, so it was not possible to use shielded #4 AWG wires for the traction bus. However, the custom cable described in Fig. 6 meets the space requirements. This cable comprises four adjacent 10-AWG wires, creating a flat cable that is four times wider than it is tall. The manufacturer claims that this configuration reduces the inductance and radiated noise as compared to an equivalent round wire, and modeling of these cable configurations supports this claim, as presented in Fig. 7. To test this performance, the NEAT facility conducted qualitative testing to assess radiated emissions on candidate

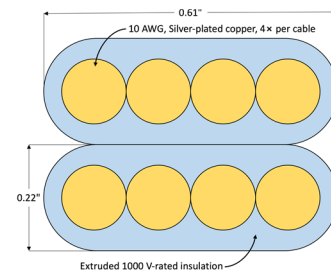

Fig. 6. The X-57 annunciator panel with electric propulsion system indication.

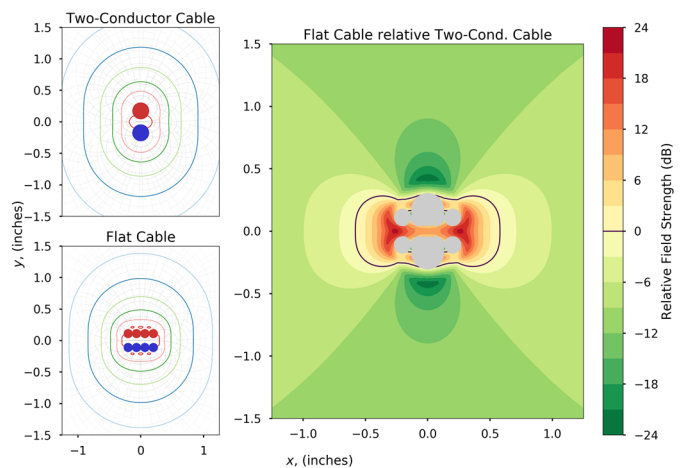

Fig. 7. Near-field electric and magnetic field strength comparison between traditional two-conductor cable and the X-57 “flat cable” configuration.

cabling for the X-57 flight demonstrator. The NEAT test setup has a 125-kW motor-inverter and DO-160 line impedance stabilization network equipped for radio frequency emission measurement. Testing indicated that there was no significant difference in radiated emissions between the baseline shielded cable and the unshielded cables described in Table I; however, emissions are sensitive to the specific equipment being tested. The flat cable was selected because that cable fit the geometry restrictions in the Mod III wing without noticeable EMI concessions. There may be a benefit given the ability to tightly stack the supply and return cables to cancel radiated fields.

VI. COMMAND SYSTEM

A. Overview

The X-57 command bus is used to control the electric motors and provides aircraft health and status. The command flow consists of throttle encoders (TEs) which digitize the existing Tecnam throttle lever positions and the electric motor controllers, which use this position as a torque target. The architecture of the bus follows the Controller Area Network (CAN) standard and includes both standard CAN messages and the higher-level CANopen protocol. The CAN protocol offers various benefits including error detection, message arbitration, multicast reception, and prioritization [4]. The single-wire pair required for the CAN physical layer and a lack of a bus controller simplify implementation. All devices on the X-57 command bus adhere to the CAN2.0A standard and operate at 1,000 kbaud. The CANopen system is a higher layer protocol, allowing configuration of nodes and defining the internal device structure of each device on the network [5]. Since CANopen is a higher layer of protocol built on CAN, components using the CANopen protocol can interoperate on a bus with components that communicate with standard CAN messaging.

The components of the command bus were selected based on robustness and compatibility with the CAN bus. Because some components use the CANopen standard, precautions were taken to ensure the components using the standard CAN protocol do not interfere with the additional functionality of the CANopen devices. The CANopen protocol uses a portion of the message identification (first 4 bits of the message ID) of the CAN structure to identify configuration parameters and data parameters. By considering the data parameter identifiers used by CANopen, and carefully selecting the device identifications both for the CANopen and standard CAN devices, message collisions between the two standards is prevented. A diagram of the command system network is shown in Fig. 8.

B. Components

The battery management system (BMS) is a custom solution built by Electric Power Systems (EPS). It uses a CANopen standard that has been customized to fit with the X-57 architecture. The BMS provides battery health and status information to the CAN bus, which can help convey relevant information to the pilot.

The CMC is a custom solution provided by Joby Motors (Santa Cruz, California) and uses a CAN interface. The motor controller communicates health and status information for itself

TABLE I. NEAT FACILITY EMI CABLE TEST MATRIX

Cable	Manufacturer	Part number	Configuration
1	Champlain	EXRAD-XLX2X	Round/Shield
2	TE Connectivity	WMSHF260-0113-2-9	Round/Unshield
3	Method	CD-0322-1B	Flat/Unshield

and the motor, including torque, speed, and temperatures, that can be used to provide situational awareness to the pilot.

The MoTeC synchronous versatile input module (SVIM) is an analog to digital converter that transmits the data on a CAN bus. These modules collect data at high rates (5000 samples per second) and high resolution (15-bit) synchronously with other modules as needed. For the X-57 application, these modules are used to record the blade pitch angle and temperatures associated with the CMCs and the motors. The size and capability to transmit on CAN make these devices useful in an EMI environment research capacity.

The MoTeC Pty Ltd (Melbourne, Australia) D175 is a full-color, customizable display and is the main interface between the pilot and the command bus. Fig. 9 shows a sample screen of the display. These screens show health and status information from the BMS, CMC, and TEs while also showing warnings and alarms based on the values from these systems. The screens are toggled with switch inputs incorporated into the display. Along with the situational awareness provided by this

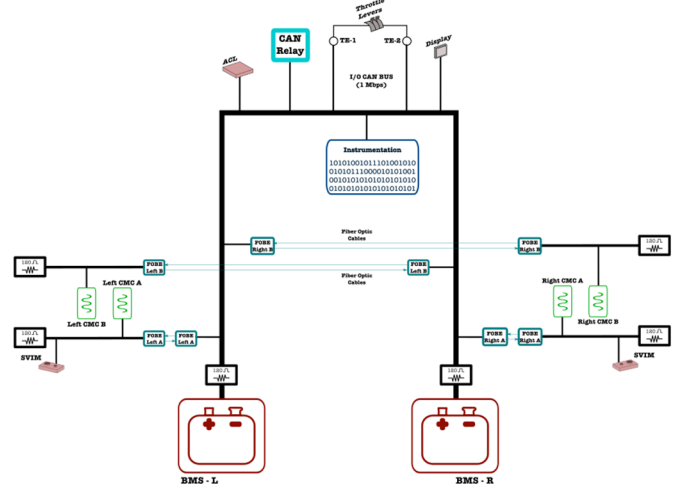

Fig. 8. The X-57 command system network diagram.

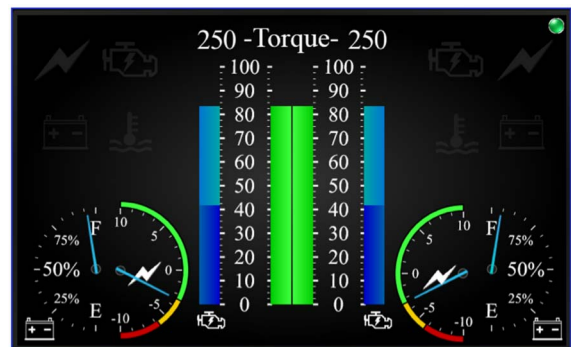

Fig. 9. The X-57 cockpit display reflects the duality of the X-57 system design. Indicators include State of Charge, discharge rate, and throttle position.

display, the screens provide additional information that aid in troubleshooting on the ground and quickly diagnosing problems in the air. The two main pages for the pilot are toggled using a simple switch, while the remaining pages are accessed by combining the switch with an eight-position rotary switch. This setup allows 16 different pages with information about the health and status of various X-57 components.

A MoTeC advanced central logger (ACL) works as the processor for the display. The logger collects all of the relevant signals, performs mathematical operations on them, and feeds the results to the display. As such, the logger is used to determine the health and status of the battery and motors and to provide any alarms or warnings to the pilot by way of the display. The ACL also controls the light-emitting diode (LED) lights on the D175 display that provide quick information to the pilot, such as battery state-of-charge (SOC) or emergency location. Finally, the ACL serves as the interpreter for the SVIMs. The SVIM transmits data on the CAN bus in a proprietary format that is not easily interpreted by the instrumentation stack. Therefore, data that come from the SVIM are read by the ACL and then retransmitted to the command bus for the instrumentation stack to record. Since the instrumentation stack time-tags all the data being recorded, there is an inherent delay between the time when the SVIM transmits the data and the instrumentation stack records the data after ACL retransmission. This delay is acceptable because of the slow rate of change of the data being collected by the SVIM.

The two throttle encoders used in the project are Baumer Ltd. (Southington, Connecticut) rotary encoders that are CANopen compliant. These devices measure rotation of the stock Tecnam throttle levers and put the data on the CAN bus. Each device also has dual encoders to provide greater reliability.

Western Reserve Controls (WRC) (Akron, Ohio) fiber optic bus extenders (FOBEs) are commercial products that are customized for X-57 by repackaging for fit and robustness requirements. These bus extenders convert the electrical signals on the copper CAN bus to optical signals on fiber optic cables and convert them back to electrical signals on a copper segment closer to remote CAN components. The distance of the CMCs from the rest of the CAN bus components, and their use of high current to run the motors, present a higher risk of EMI in the copper CAN bus segments. This risk is mitigated by separating the segments with FOBEs and fiber optic cables. Using fiber optic cables also reduces the risk of reaching the line-length limits of the CAN bus standard and susceptibility radiated EMI from the traction power bus.

A CAN-controlled relay box is a product by Blink Marine (Milan, Italy) that allows relays to be opened and closed using CAN messages. This provides an audio annunciator capability that can provide key alarms to the X-57 pilot. These alarms are defined collaboratively with the test pilots, system designers, and operations team. The audio annunciator works by grounding specific inputs to the device, resulting in output in the form of an audio message. CAN messages from the ACL to the relay box energize relays which completes the circuit to the annunciator, allowing the ACL to determine any alarm states and to alert the pilot both audibly (through the audio annunciator) and visually (through the D175 display). The audio

annunciator that uses the relay box is a PRD60 accessory device developed by PS Engineering (Lenoir City, Tennessee). The device contains six pre-programmed messages and the ability to mute messages by acknowledging them with a simple push-button.

The X-57 instrumentation system contains a CAN bus monitoring card that will interface to the command system. This card is used to only listen to the traffic on the CAN bus and record all of that traffic with a time tag. A subset of these messages is also transmitted to the ground station.

C. Risk Mitigation

The X-57 command bus is considered a mission-critical system, but not a safety-critical system. This designation is possible because the pilot does not need to rely on the command bus for the safe operation of the X-57 flight demonstrator aircraft. All of the safety-related information provided by the CAN bus is also independently measured and displayed on the right-hand instrument panel in the cockpit. The X-57 aircraft is also designed with an unpowered reversion mode in which the pilot can safely control the aircraft and complete and unpowered, higher speed landing. This capability is facilitated by limiting flight to the area over Rogers dry lakebed (Edwards, California), which provides ample landing options.

Although the command system itself is not safety-critical, the CMC and BMS, which are safety-critical components, do interface with the command bus. A command bus failure for the X-57 flight demonstrator aircraft could result in a loss of communication to and from the BMSs or CMCs. Therefore, the BMS and CMC are designed to behave in a safe manner in case of this failure. The BMS operates independently and only reports health and status to the command bus. It also reports operational status directly to the independent annunciator panel in the cockpit. The CMC, however, relies on command inputs from the command bus, so the CMC includes safety features to allow safe operation of the X-57 aircraft in spite of command bus interruption. If command is lost from the throttle encoders, an internal CMC counter will increment. During an initial count up period, the last verified torque command is held and executed by the CMC. After a preset time, the CMC will execute a gradual ramp-down of the commanded torque to idle. These features enable continued operation for a short time after command bus failure, whereas the preset timeout prevents an indefinite running of the motors in the case of ground-testing when the aircraft is being operated remotely. As a mission-critical system, additional measures are taken to reduce the risk of various command bus failures, as detailed below.

While the CAN standard makes the command bus resistant to EMI, steps are taken to further reduce the risk of the high-power systems introducing electric noise into the command bus. Mod II to the X-57 aircraft will locate the CMC and motors in the same location as the original Tecnam engines. Mod III to the X-57 aircraft, however, will require the command bus to extend to that point. As such, the FOBEs are used to incorporate the fiber optic cable segment between the fuselage and the CMC for both Mod II and Mod III. These FOBEs operate in such a way that they are invisible to the devices on the CAN Bus. The devices on either end of the fiber optic link behave no differently than if they were all connected by way of a copper bus.

To reduce the risk of throttle command failure, the Baumer throttle encoders used to measure the angle of the Tecnam throttle levers contain a redundant encoder. The component transmits the measurement from each encoder onto the CAN bus. The components that read this information can then act on any discrepancies between the data reported by each encoder. A discrepancy between the two encoders is a case wherein which the CMC will consider the incoming command as invalid and revert to the command bus failure mode, as described above. Further risk mitigation for the throttle encoders involves the physical component. The initial design to digitize the throttle position used a cable-pull encoder. This method was revised to use a rotary encoder that has a direct mechanical connection to the throttle levers to reduce the chance of the cable snagging.

The physical layer of the command bus also contains redundancy for the motor commands. The data from each throttle encoder component go to two CMCs on each side of the aircraft. To prevent a complete failure on one side in the case of a physical break of the command bus, the physical tie-in of each CMC connected to the same motor is located on opposite ends of the command bus. Therefore, a break on one side of the command bus ensures a physical path from the throttle encoders to at least one CMC on each side as indicated in Fig. 9.

VII. FAILURE ANALYSIS

The redundancy architecture described above minimizes the scope of single-mode faults, and the component testing will reduce the likelihood of faults occurring during the flight phases of the SCEPTOR project. These assumptions must be analyzed formally to ensure no faults with severe consequences are likely to occur at critical moments. A Failure Modes and Effects Analysis (FMEA) identifies the repercussions of each relevant failure. When coupled with overarching hazard tracking and emergency procedure development and testing in a full cockpit simulator with the X-57 test pilots, this approach greatly reduces the exposure to catastrophic failures.

The X-57 FMEA was limited to single-point failure modes of the power and communication systems and identifies procedural mitigations and failure classifications. The analysis focused on top-level components and linkages and will identify unique failure case for each component. Some components have multiple sub-component-level failures, but their effect on that component and the rest of the system is the same; therefore, only unique failure cases are considered. The analysis began by constructing a full power and communication architecture schematic, shown in Fig. 10.

The diagram depicts the X-57 airplane in the fully integrated Mod IV configuration, with the 12 in-board high-lift electric motor/propeller propulsors. The Mod II and Mod III versions of the diagram would omit the 12 inboard propulsors, as those are introduced as part of the Mod IV development. There is very little difference to the power and communication architecture between the Mod II and Mod III airplanes. A selection of the nearly four dozen X-57 Mod II and Mod III failures identified in the FMEA process are described in Table II. Mod IV failures also include all permutations for any specific inboard motor or groups of inboard motors, but are not discussed in this paper.

There were two primary failure situations that the team identified as critically important for mitigation: asymmetric thrust condition for the Mod III configuration, and an in-flight battery fire. These two failures represent conditions that may be unrecoverable for the pilot. The X-57 system has many design and procedural considerations to prevent these conditions, and mitigation strategies for these situations are in place.

The Mod III asymmetric thrust scenario is a condition such that only one of the wingtip electric motors provides thrust, and the resulting moment cannot be trimmed out with the rudder and elevators. The stock Tecnam aircraft can trim a one-engine-inoperable (OEI) condition, and the Mod II aircraft can trim an OEI because the locations of the propulsors and location of the thrust generation is the same. In Mod III, however, by placing the propulsors at the wingtips, the effective moment arm is increased beyond the capacity of the rudder to counteract. In this

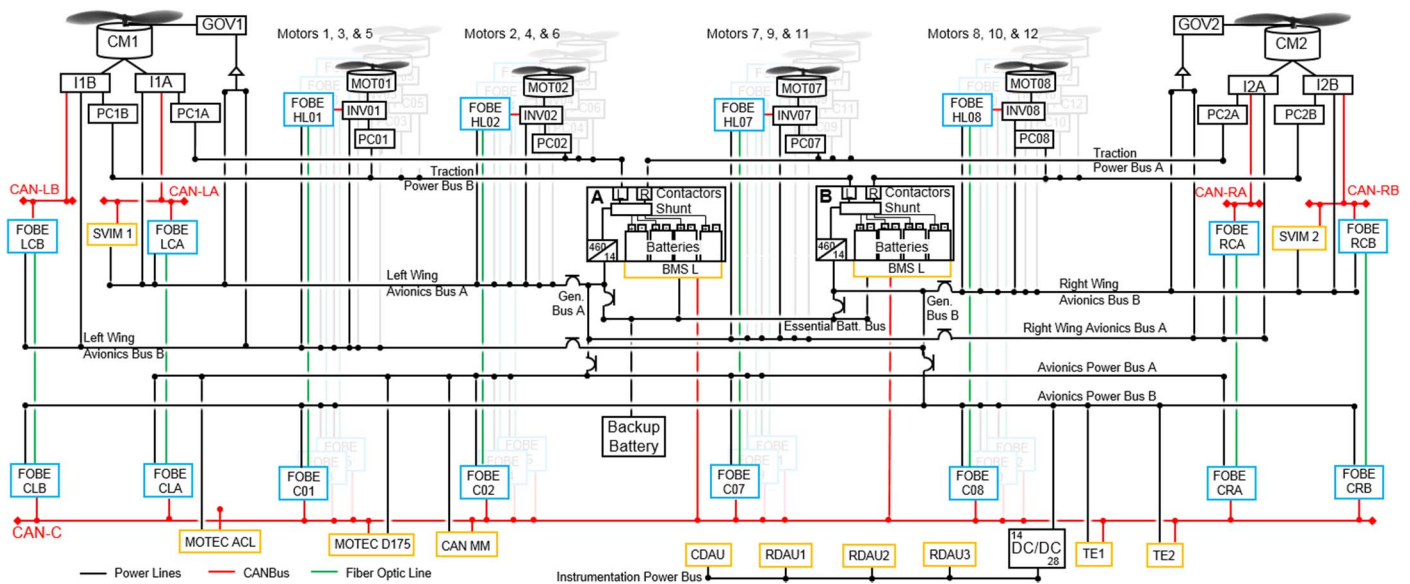

Fig. 10. The X-57 command system network diagram.

situation, it is better to disable both propulsors (operating as an unpowered glider) than to operate only one motor. Depending on the type and severity of the failure, the pilot may elect to remove power from the operational side or de-rate to 50 percent (a condition which is still trimmable with the stock rudder).

The battery fire or thermal event scenario is when one or both of the lithium-ion traction batteries are on fire or in thermal runaway. This condition is critical, as it not only degrades the power available to the motors for thrust, but could burn through structural members inside the fuselage. The battery features a vent system that segregates any ejecta or noxious gases from the pilot. Battery fire mitigation includes fire prevention methods, best practices from industry, and design features from the lithium battery systems developed by NASA for the International Space Station.

These two failure scenarios provide a starting point for identifying component-level failures and their respective criticality status (safety-critical, mission-critical, or negligible). Table II describes a selection of the identified failures. The Failure Scenario Matrix was derived from the NASA Orion PA-1 project redundancy analysis. In the nominal case when all systems are operating, all systems are green, for “operational”. Each row describes a failure and the impacts on related components, shown with an *F* (failed component), *D* (degraded performance) or *I* (inoperable) to show when a component failure impact other components.

Each failure receives a criticality designation, which is used by the test pilot and operations engineers for mitigation and recovery strategies. Failures categorized as safety-critical, which are a direct result of an asymmetric thrust condition, a battery fire or thermal event, or a loss-of-power condition in which the airplane effectively becomes an unpowered glider and an emergency landing is unavoidable. For instance, the *Battery Contactor (4x)* scenario indicates that both contactors on each battery pack (a total of four) have failed in the open position, removing all high-voltage power from the batteries to the traction bus. The motor controllers and cruise motors therefore no longer have traction power and cannot provide thrust to the airplane, so they are shown with an *I* to indicate “inoperable” in Table II. Alternatively, in the *Gen. bus (DC conv.) A||B* scenario, one generator bus DC converter can no longer provide 14 VDC to the avionics buses, but the remaining one continues to operate nominally. No other systems are impacted, so this scenario is categorized as *N* or “negligible”.

VIII. CONCLUSION

The SCEPTOR project is a rapid-execution, build-fly-learn experiment opportunity with a comparatively low budget and limited schedule. Careful design of the developmental systems and thorough analysis of these systems allow for a more agile project while still addressing the thesis that propulsion airframe integrations enabled by electric propulsion systems can be a net benefit to aircraft performance. Many of the X-57 aircraft systems are simpler than their commercial counterparts so that the research team can focus only on the handful of technologies that are being developed. The traction power system, however, is one major exception; this system is developmental and resources are limited, so careful consideration of the path to NASA X-Plane flight qualification is appropriate and necessary.

TABLE II. X-57 MOD II AND MOD III FAILURE SCENARIO MATRIX

Failure Scenario	Cruise Motor (1 2)	Cruise Motor (1&2)	MC / inverter (1x)	MC / inverter (2x)	MC / inverter (4x)	Pitch controller (s)	Cruise Contactor (1x)	Fiber Optic Modems	Traction bus (A B)	Traction bus (A&B)	Battery (A B)	Battery (A&B)	Generator bus (A B)	Wing av. bus (A B)	Criticality
Single cruise motor	F														S
Single motor controller	D		F												M
Quad motor controller		I			F										S
Prop Pitch feather (1x)	I					F									S
Cruise contactor (1x)	D		D				F								M
Fiber Optic Modem	D		I					F							M
Traction bus A B (L R)	D		D						F						M
Traction bus A&B (L&R)		I		I						F					S
Battery A B (therm. evt.)	D		D						I		F		I		S
Batt A&B (therm. evt.)		I			D					I		F			S
BMS (L R)	D			I				I			F				S
BMS (L&R)	D		I									F			S
Battery contactor (1x)	D		I						D		F				M
Battery contactor (4x)		I			I					D		F			S
Gen. bus (DC conv.) A B													F		N
Wing av. bus A B (L R)	D		I					I							F
Wing av. bus A B (L&R)	D		I					I							M

Operational (Green), Degraded performance (Yellow), Inoperable (Light Blue), Component failure (Red), Land as soon as possible (Dark Red), Land as soon as practical (Orange), Assess after flight (Light Green)

REFERENCES

- [1] A. Dubois, M. van der Geest, J. Bevirt, S. Clarke, R. J. Christie, and N. K. Borer, “Design of an electric propulsion system for SCEPTOR’s outboard nacelle,” AIAA-2016-3925, 2016.
- [2] N. Borer, M. Patterson, J. Viken, M. Moore, S. Clarke, M. Redifer, et al., “Design and performance of NASA SCEPTOR distributed electric propulsion flight demonstrator,” AIAA 2016-3920, 2016.
- [3] *Wiring Aerospace Vehicle*, SAE Aerospace Standard AS50881F, 2015.
- [4] Robert Bosch GmbH, *CAN Specification, Version 2.0*, Stuttgart, 1991, http://www.bosch-semiconductors.de/media/ubk_semiconductors/pdf_1/canliteratur/can2spec.pdf [cited 27 March 2017].
- [5] CAN in Automation, “CANopen – The Standardized Embedded Network,” <https://www.can-cia.org/can-knowledge/canopen/canopen>. [cited 3 April 2017].

RECOMMENDED READING

- [6] S. Clarke, and M. Moore, “Convergent Aeronautics Solutions Project – SCEPTOR – Scalable Convergent Electric Propulsion Technology and Operations Research,” NASA DFRC-E-DAA-TN37115, 2016.
- [7] S. Clarke, “SCEPTOR Power System Design: Experimental Electric Propulsion System Design and Qualification for Crewed Flight Testing,” NASA DFRC-E-DAA-TN32895, 2016.
- [8] S. Ginn, and S. Clarke, “Spiral Development of Distributed Electric Propulsion from Ground to Flight,” NASA DFRC-E-DAA-TN36914, 2016.
- [9] J. Murray, and J. Lechniak, “The LEAPTech Experiment, Approach, Results, Recommendations,” NASA DFRC-E-DAA-TN36158, 2016.
- [10] K. Papatthakis, K. Kloesel, Y. Lin, S. Clarke, J. Ediger, and S. Ginn, “Design and development of a 200-kw turbo-electric distributed propulsion testbed,” AIAA 2016-4611, 2016.
- [11] R. Jansen, C. Bowman, and A. Jankovsky, “Sizing power components of an electrically driven tail cone thruster and range extender,” AIAA-2016-3766, 2016.