

# A new type of energy-saving electric drive.

## The most efficient way to save energy .

Dudarev V.P.

E-mail : v.p.1963@internet.ru

**Abstract:** There are known DC and AC electric drives with excitation control, containing negative feedback circuits for speed and flow derivative. In such drives, with an increase in the number of elements included in them, the efficiency always decreases proportionally to the number of links included in them. That is, if the power supplied to the drive motor is  $P_{el} = I \times U$  , then the power on the drive motor shaft will be equal to:

$$P_{dr} = P_{el} \times k_{dr} , \quad \text{where}$$

$k_{dr}$  - efficiency of the drive motor.

The generator will supply the following power:

$$P_g = P_{el} \times k_{dr} \times k_g , \quad \text{where}$$

$k_g$  - generator efficiency.

Further, the consumed power will also decrease as the number of links included in the chain with other consumers increases. The device described below relates to the field of electrical engineering, namely to electric drives with speed feedback. The drive uses a parallel oscillatory circuit in which current resonance is achieved. A brushless anchor of a synchronous AC electric motor DCm is built into this parallel oscillatory circuit, which is powered by a brushless anchor of an AC generator G made according to the synchronous generator scheme. The anchor of the generator G and the motor DCm are on the same shaft, forming a single system that is driven by the drive motor DM. When the current is resonant in the parallel oscillatory circuit, the active current in the branched section of the circuit where the anchor of the motor DCm is located can be many times greater than the active current in the unbranched section of the circuit where the anchor of the generator G is located.

**Key words:** consumed power, output power, electric drive with parallel resonant circuit, generator-motor system (G-DCm) on one shaft.

There are known DC and AC electric drives with excitation control, containing negative feedback circuits for speed and flow derivative. In such drives, with an increase in the number of elements included in them, the efficiency always decreases proportionally to the number of links included in them. That is, if the power supplied to the drive motor is  $P_{el} = I \times U$  , then the power on the drive motor shaft will be equal to:

$$P_{dr} = P_{el} \times k_{dr}, \quad \text{where}$$

$k_{dr}$  - efficiency of the drive motor.

The generator will supply the following power:

$$P_g = P_{el} \times k_{dr} \times k_g, \quad \text{where}$$

$k_g$  - generator efficiency.

Further, the consumed power will also decrease as the number of links included in the chain with other consumers increases. The device described below relates to the field of electrical engineering, namely to electric drives with speed feedback. The technical result of its application is saving electric power feeding the drive motor of the device. The electric drive contains: a tachogenerator TG with a magnetic amplifier MA and negative feedback circuits for speed and flux derivative; a drive motor DM, which is powered by a power source PS; an energy-saving device G - DCm, which contains: a synchronous alternating current generator G, the armature winding of which does not have a collector (because it does not have a voltage and current output to the external circuit) and is directly connected to a parallel oscillatory circuit in which the DCm motor armature is built in. The DCm motor armature operating in the synchronous motor mode also does not have a collector and is powered directly from the generator armature G. The generator armature G and the DCm motor armature are located on the same shaft. At the same speed of rotation of the shaft on which they are located, the voltage on the anchor operating in the generator mode should be greater than the voltage on the anchor operating in the engine mode by 1,5–2,5 times. The mechanical and electrical diagram of the drive is shown in Figure 1.

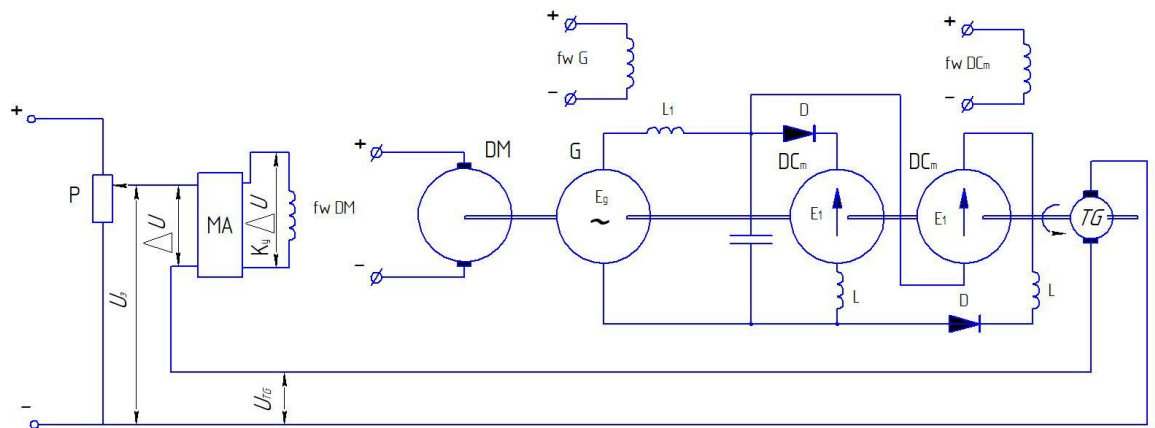

Fig. 1. Schematic diagram of an electric drive with a parallel resonant circuit.

The direct current tachogenerator measures the actual rotation frequency of the system located on a single shaft. At the input resistance of the amplifier MA, the setting voltage  $U_3$ , which is a function of the set rotation frequency, is compared with the tachogenerator voltage  $U_{TG}$ , proportional to the rotation frequency of the system located on a single shaft. When the rotation frequency of the system located on a single shaft deviates from the set speed, the voltage difference  $\Delta U = U_3 - U_{TG}$ , supplied to the amplifier changes. The voltage  $K_Y \times \Delta U$  from the amplifier output is supplied to the control winding of the magnetic amplifier, amplified by  $k$  times and supplied to the excitation winding of the DM motor and the excitation winding of the armature operating in the DCm motor mode. The rotation frequency of the DM motor and the entire system located on a common shaft will change so that the deviation of its value from the set value will decrease.

The counter emf of the armature operating in the motor mode is directed opposite to the emf of the armature operating in the generator mode. Diodes D prevent current flow in the direction of the counter emf of the armature winding operating in the motor mode. It is also clear from the figure that this is a circuit with a parallel connection in the branched part of the circuit of a capacitor and inductance, in which the components of the circuit are selected in such a way that parallel resonance is realized during circuit operation. The operation of the system is as follows. The drive motor accelerates the system generator armature G - motor armature DCm located on the same shaft to the speed of their start of operation. As was said above, the ratings of the capacitor C, inductance L, resistance  $R_2$  are selected in such a way that at the operating frequency of the generator armature G, a resonance of currents occurs in the circuit loop with an amplitude of current oscillations in the branched part of the circuit many times exceeding the amplitude of oscillations in the unbranched part of the circuit. If an electric circuit contains reactive elements connected in series and in parallel, partial resonances may occur in the circuit when the input voltage and current are in phase. If the inductive resistance of the unbranched part of the circuit is compensated by the capacitive resistance of the parallel circuit, a voltage resonance will be observed in the unbranched part of the circuit. This will negatively affect the operation of the drive. Therefore, the inductive resistance of the generator armature winding G of the unbranched part of the circuit must be compensated by introducing capacitive resistance into the unbranched part of the circuit, and the reactive part in the unbranched section of the circuit must be equal to zero. The generator armature must have only active resistance.

In Fig. 1, the inductive resistance of the generator armature G and the capacitive resistance compensating it are not shown conditionally. Let us designate the active resistance of the generator armature as  $R_1$  and consider the circuit with the definition of specific parameters of the circuit.

For this, we will use Figure 2.

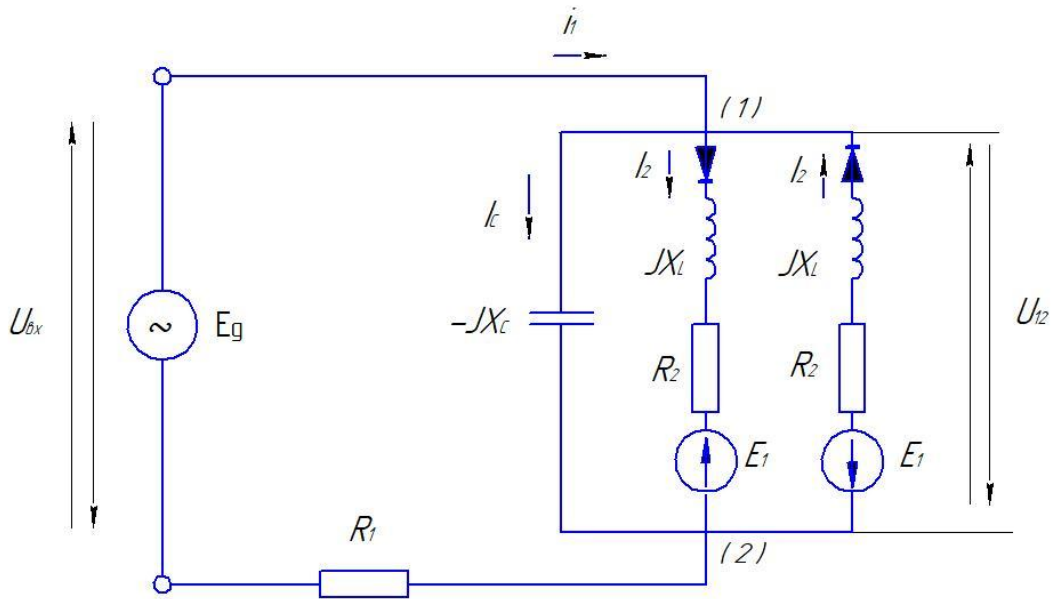

Fig. 2 Complex circuit with parallel resonant circuit

Let us consider an example of an electrical circuit of a G - DCm system on one shaft with a parallel resonant circuit. For a complex circuit, using the available data, we will determine the inductive resistance of the coil  $X_L$ , the resistance of the resistor  $R_2$ , at which the resonance phenomenon will be observed in the circuit. We will determine the quality factor of the oscillatory circuit, the complex currents in the resonance mode and the power given off by the anchor operating in the generator mode  $E_g$  and consumed by the anchor operating in the motor mode  $E_1$  :

Let  $U_{BX} = 100 \text{ V}$ ;  $I_1 = 10 \text{ A}$ ;  $R_1 = 1 \text{ Ohm}$ ;  $X_C = \frac{1}{2\pi f C} = 0,1 \text{ Ohm}$

$E_1 = E_2 = 50 \text{ V}$ ,  $f_{BX} = 50 \text{ Hz}$

**Solution.** The circuit in Fig. 1 operates with a harmonic input effect. It is important to note that the problem statement specifies the effective values of the input voltage and current. Resonance in the circuit will occur when the input current and input voltage are in phase. This will happen when the capacitive admittance of the capacitor is compensated by the inductive admittance of the branch  $R_2$ —L parallel to the capacitor (current resonance). In this case, resistor  $R_1$  does not affect the phase characteristics of the parallel circuit, therefore, the current resonance condition in the circuit can be written as  $I_m[Z_{BX, KOHT}] = 0$ , where  $Y_{BX, KOHT}$  is the complex admittance of the resonant circuit  $R_2$ —L—C:

$$R_2 Y_{BX, KOHT} = \frac{1}{-jX_C} + \frac{1}{R_2 + jX_L} = \frac{j}{X_C} + \frac{R_2}{R_2^2 + X_L^2} - \frac{X_L}{R_2^2 + X_L^2} j$$

Let's equate the imaginary part of the circuit's conductivity to zero:

$$\frac{1}{X_C} - \frac{X_L}{R_2^2 + X_L^2} = \frac{1}{0,1} - \frac{X_L}{R_2^2 + X_L^2} = 0$$

In this equation there are two unknown resistances:  $R_2$  and  $X_C$ . Let's make another equation using Ohm's law:

$$\frac{U_{BX}}{I_{BX}} = Z_{BX} = R_1 + Z_{BX, KOHT} = R_1 + \frac{R_2^2 + X_L^2}{R_2}$$

The equation is written for complex current and voltage, and only their effective values are specified. That is, the lengths of the vectors on the complex plane are specified, there is no information about phase shifts, and the reference signal relative to which the phases are determined is not specified. In this case, any voltage or current in the circuit can be taken as the reference signal. The calculation will be simplest if the input current is taken as the reference signal ( $\alpha = 0^\circ$ ). Then the complex value of the current can be calculated:

$$I_{BX} = I_1 \times \cos 0^\circ + j \sin 0^\circ = 10 \text{ A}$$

In resonance mode, the input voltage and current are in phase. Then the complex value of the input voltage is:

$$U_{BX} = U \times \cos 0^\circ + j U \times \sin 0^\circ = 100 \text{ V}$$

Now the system of equations for calculating  $R_2$  and  $X_L$  takes the form:

$$\frac{1}{0,1} - \frac{X_L}{R_2^2 + X_L^2} = 0$$

$$\frac{100}{10} = R_1 + \frac{R_2^2 + X_L^2}{R_2} = 1 + \frac{R_2^2 + X_L^2}{R_2}$$

Solving the system, we obtain the values  $R_2 \approx 0,001111 \text{ Ohm}$ ,  $X_L \approx 0,11 \text{ Ohm}$

$$X_L = 2 \times \pi \times f \times L, \quad \rightarrow \quad L = \frac{X_L}{2 \times \pi \times f} = \frac{1}{2 \times 3,14 \times 50} = 0,0003183 \text{ Gn}$$

$$X_C = \frac{1}{2 \pi f C} = 0,1 \quad \rightarrow \quad C = \frac{1}{2 \times \pi \times f \times X_C} = \frac{1}{2 \times 3,14 \times 50 \times 0,1} = 0,03183 \text{ F}$$

$$g_C = \frac{1}{X_C}$$

Let us write the input conductivity of the resonant circuit in the form

$$Y_{BX, KOHT.} = g_{R_{\text{ЭKB}}} = \frac{J}{X_C} + \frac{R_2}{R_2^2 + X_L^2} - \frac{X_L}{R_2^2 + X_L^2} j = \frac{J}{0,1} + \frac{0,00111}{0,01} - \frac{0,1}{0,01} j = 10j + 0,111 - 10j = 0,111$$

Let's calculate the quality factor of the resonant circuit:

$$Q = \frac{g_C}{g_{R_{\text{ЭКВ}}}} = \frac{10}{0,111} = 90,1, \quad \text{where}$$

$g_C$  — module of capacitive conductivity of the resonant circuit;

$g_{R_{\text{ЭКВ}}}$  — module of the input conductivity of the circuit.

To determine the complex currents  $I_1$  and  $I_2$ , we calculate the voltage  $U_{12}$  (see Fig. 2):

$$U_{12} = \frac{I_1}{Y_{\text{BX. КОИТ.}}} - E_1 = 90,1 - 50 = 40,1 \text{ V}$$

We will determine the currents according to Ohm's law:

$$I_2 = \frac{U_{12}}{R_2 + jX_L} = \frac{40,1}{0,00111 + 0,1j} = 396,6 + 40,1j$$

$$I_C = \frac{U_{12}}{jX_C} = \frac{40,1}{-0,1j} = -40,1j$$

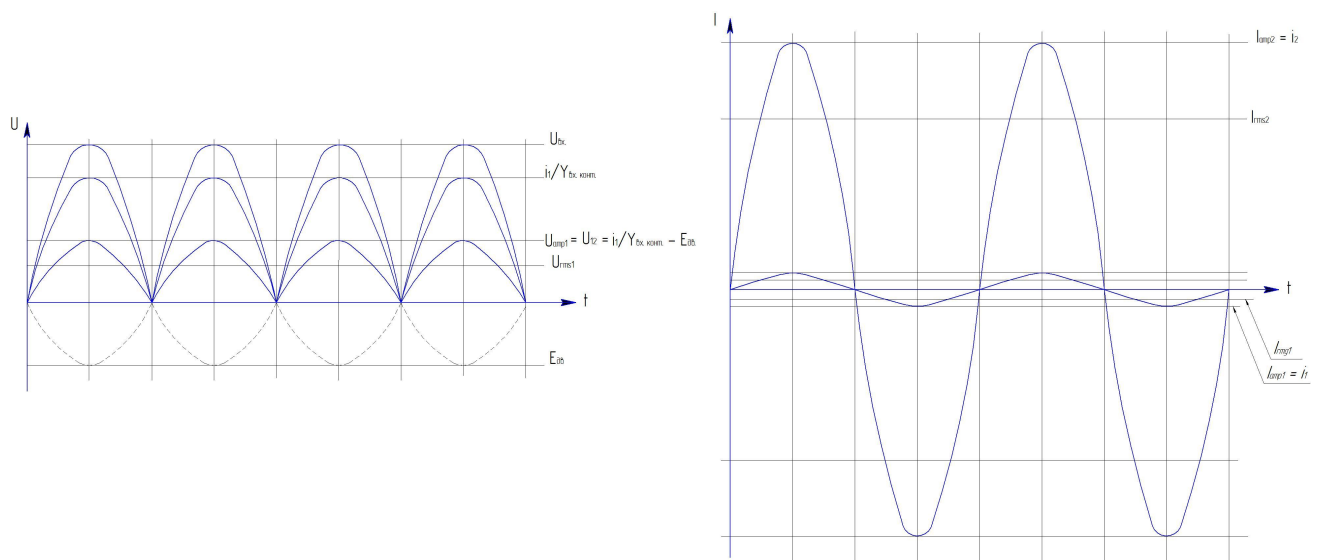

Fig. 3 Voltages and currents in the branches of an electric drive with a parallel resonant circuit.

The power supplied by the alternating current generator to the circuit with a parallel resonant circuit with voltage  $U_{\text{BX}} = 100 \text{ V}$  and current  $I_1$  is determined by the formula:

$$P_{\text{avg1}} = U_{\text{rms1}} \times I_{\text{rms1}}, \quad \text{where}$$

$P_{\text{avg1}}$  — arithmetic mean value of the armature power operating in generator mode G.

$U_{\text{rms1}}$  — the root mean square value of the armature voltage operating in the generator mode G.

$I_{\text{rms1}}$  — the root mean square value of the armature current operating in the generator mode G.

The root mean square value of the armature voltage operating in generator mode is:

$$U_{rms1} = \frac{U_{amp1}}{\sqrt{2}} = \frac{100}{1,4142} = 70,7 \text{ A}, \quad \text{where}$$

$U_{amp1}$  - the amplitude value of the armature voltage operating in the generator mode. The root-mean-square value of the armature current operating in the generator mode is:

$$I_{rms1} = \frac{I_{amp1}}{\sqrt{2}} = \frac{10}{1,4142} = 7,07 \text{ A}, \quad \text{where}$$

$I_{amp1} = I_1$  - the amplitude value of the armature current operating in generator mode.

The power supplied by the alternating current generator to the circuit is equal to:

$$P_{avg1} = U_{rms1} \times I_{rms1} = 70,7 \times 7,07 = 500 \text{ W}$$

The power received by the anchor operating in the DCm motor mode with a parallel resonant circuit, with a total voltage on the circuit  $U_{12} = 40,1 \text{ V}$  and a current strength  $I_2$  in the circuit is determined by the formula:

$$P_{avg2} = E_1 \times I_{rms2}, \quad \text{where}$$

$U_{rms2}$  - the total root-mean-square voltage between points 1 and 2 of the parallel circuit in which the anchor is located, operating in DCm motor mode.

$I_{rms2}$  - the root mean square value of the current passing through the armature operating in DCm motor mode.

The root mean square value of voltage between points 1 and 2 is:

$$U_{rms2} = \frac{U_{amp2}}{\sqrt{2}} = \frac{40,1}{1,4142} = 28,4 \text{ B}, \quad \text{where}$$

$U_{amp2} = U_{12}$  - the total amplitude voltage between points 1 and 2 of the parallel circuit in which the anchor is located, operating in DCm motor mode.

$$I_{rms2} = \frac{I_{amp2}}{\sqrt{2}} = \frac{396,6}{1,4142} = 280,44 \text{ A}, \quad \text{where}$$

$I_{amp2} = I_2$  - the peak value of the current passing through the armature operating in DCm motor mode.

The power of the anchor operating in the motor mode will be equal to:

$$P_{avg2} = E_1 \times I_{rms2} = 50 \times 280,44 = 14022 \text{ W}$$

Thus, according to the obtained approximate calculation, in the system of generator G - DCm motor on one shaft with a parallel circuit, it is possible to obtain additional power to the power consumed by the system.

Bibliography:

1. Е.В. Миллер « Основы теории электропривода» М. Высшая школа, 1968, стр. 241-246.
2. Атабеков Г. И. Теоретические основы электротехники. Ч. 1 : Линейные электрические цепи / Г. И. Атабеков. М.: Энергия, 1978 (2-е изд. СПб.: Лань, 2008).
3. Гусев В. Г. Электроника : учеб. пособие для вузов / В. Г. Гусев, Ю. М. Гусев. М. : Высш. шк., 1991. 622 с
4. Чиликин, М.Г. Общий курс электропривода / М.Г. Чиликин, А.С.Сандлер. М. : Энергоиздат, 1981. – 576 с.