

# DISCUSSION

## 3-D Modelling

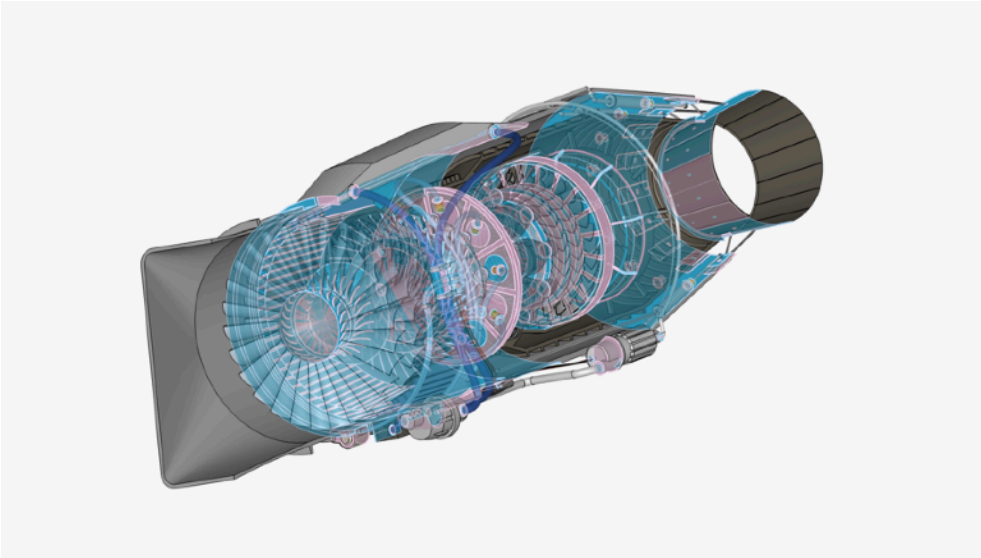

Fig.1.-Full 3-D model of Engine with differentiated exoskeleton and systems

Fig.1.2-Front-view of Engine(Turbine blades)

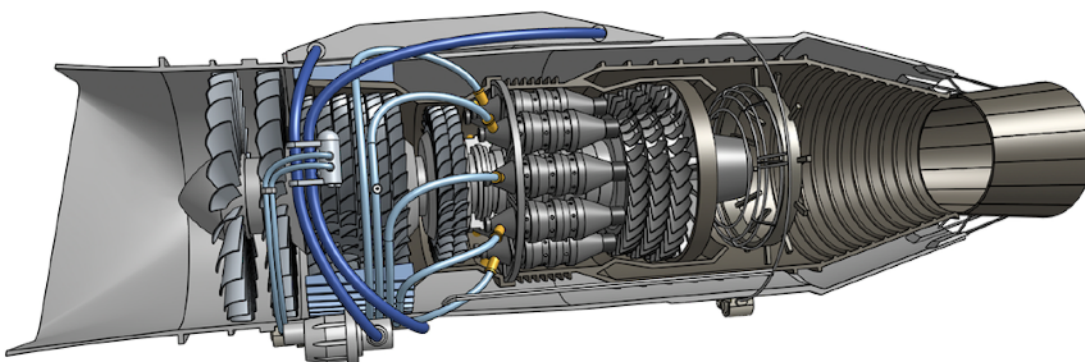
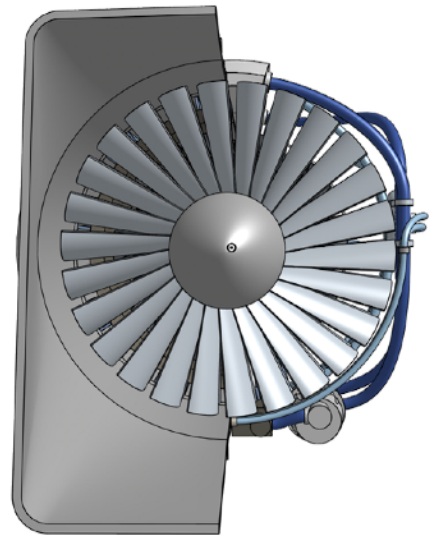

Fig 1.3: Side View of a Low Bypass Turbofan (LBPT) Engine showing major components such as intake, fan, compressor, combustion chamber, turbine, and exhaust nozzle.

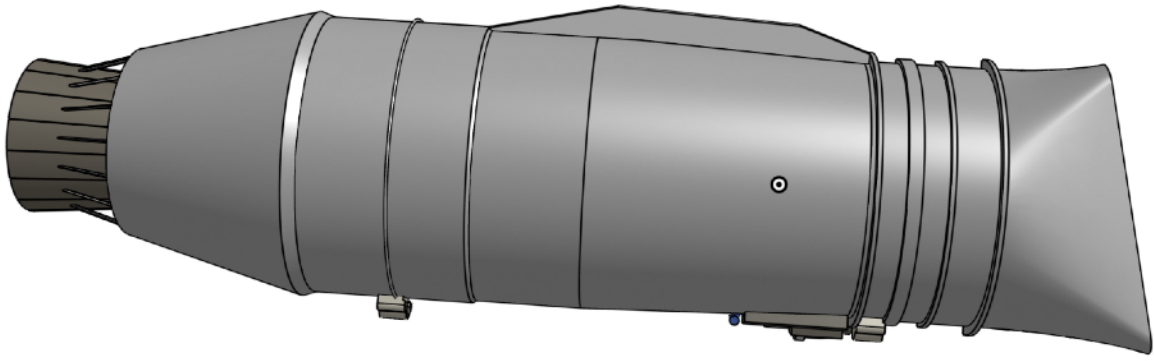

Fig 1.4: External Side View of a Low Bypass Turbofan (LBPT) Engine showing the outer casing, intake section, and exhaust nozzle.

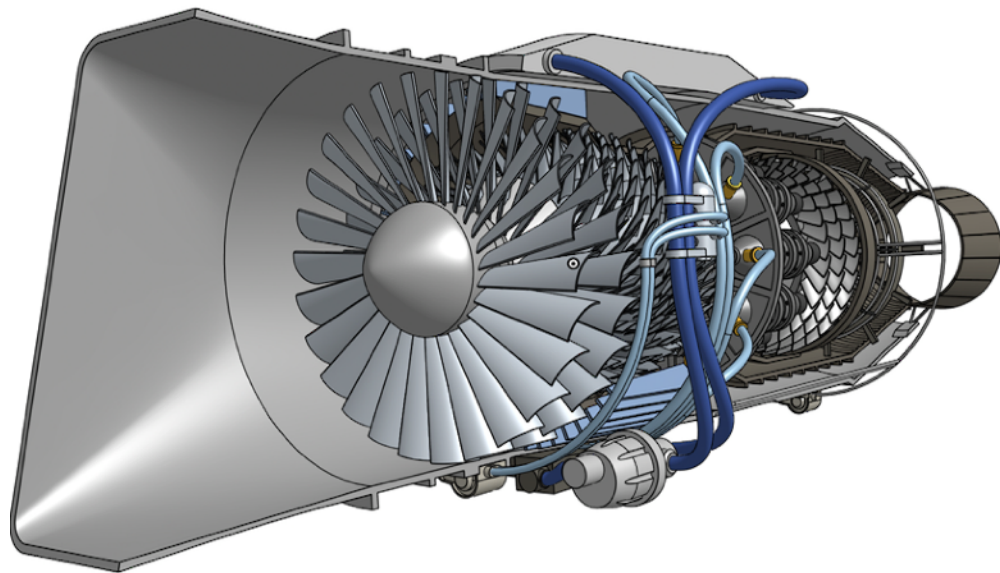

Fig 1.5: Front Perspective View of a Low Bypass Turbofan (LBPT) Engine illustrating the fan assembly, multi-stage compressor, combustion chamber, turbine system, and associated fuel piping.

# GRAPHICAL RESULTS

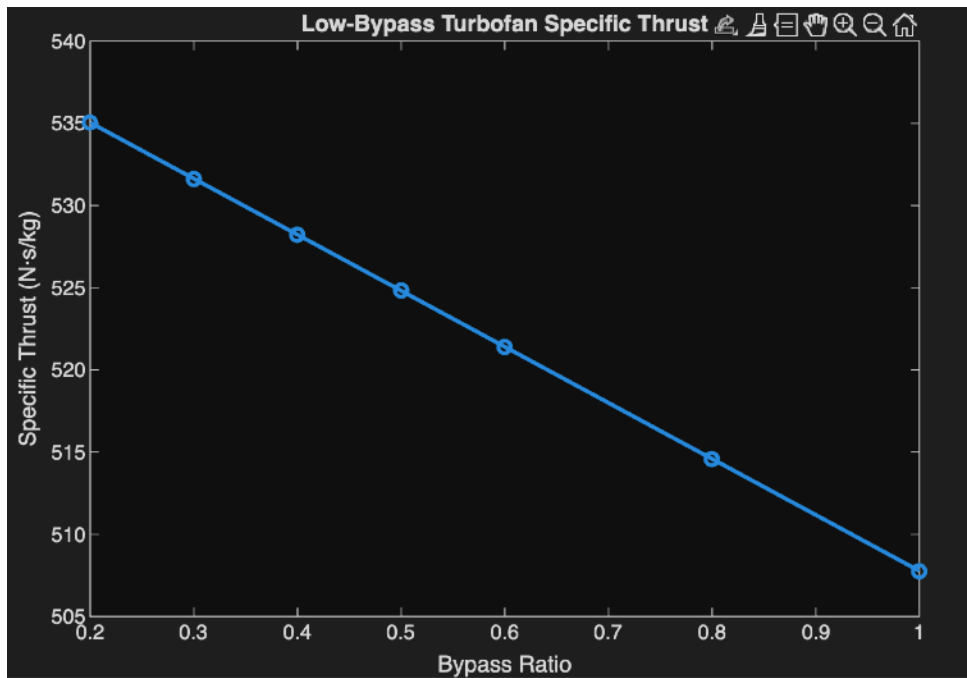
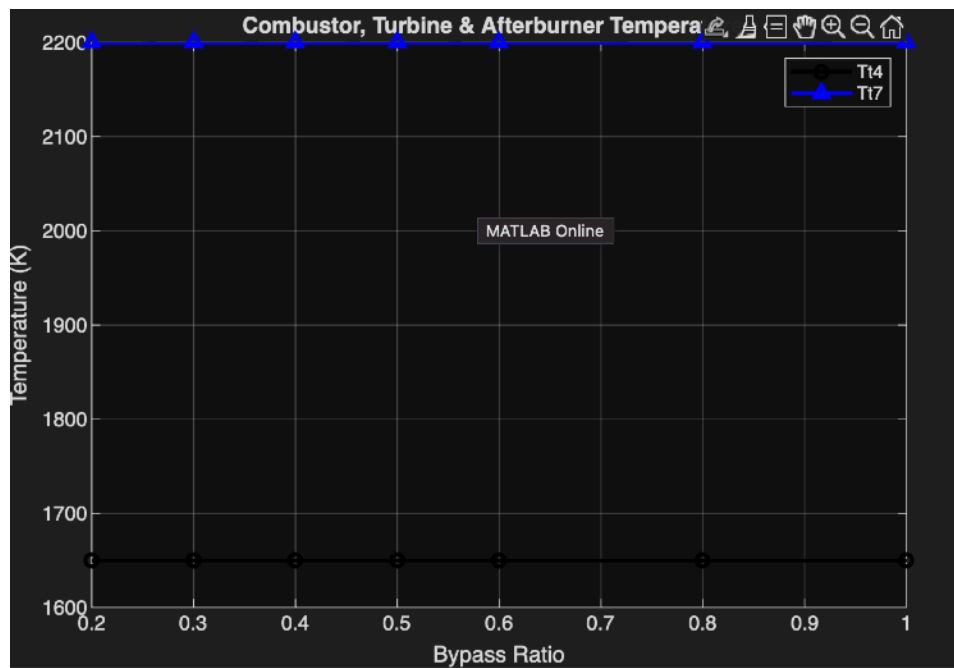

Fig 2.1- Relation between Specific Thrust and Bypass ratio of LBPT engine in Ideal Conditions

Fig 2.2- Relation between Temperature and Bypass ratio of LBPT engine in Ideal Conditions



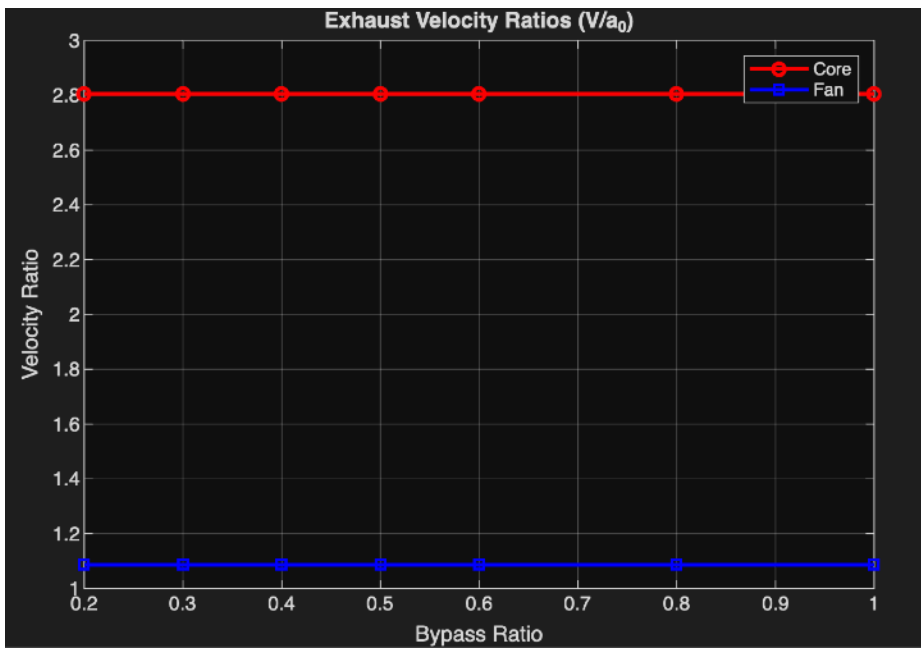

Fig 2.3- Relation between Velocity Ratio and Bypass ratio of LBPT engine in Ideal Conditions

Fig 2.4- Relation between Mach Number and Bypass ratio of LBPT engine in Ideal Conditions

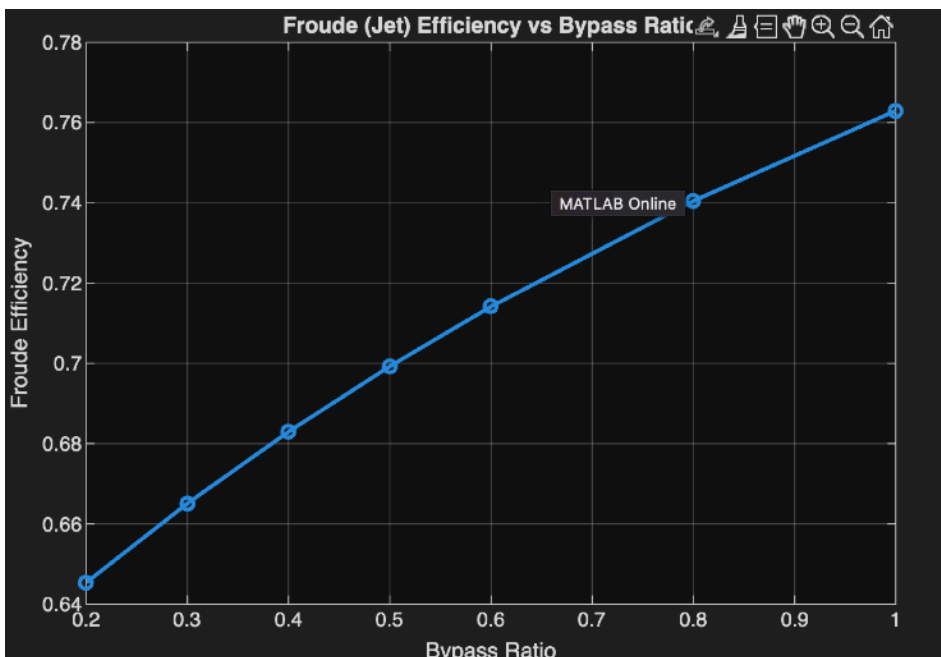
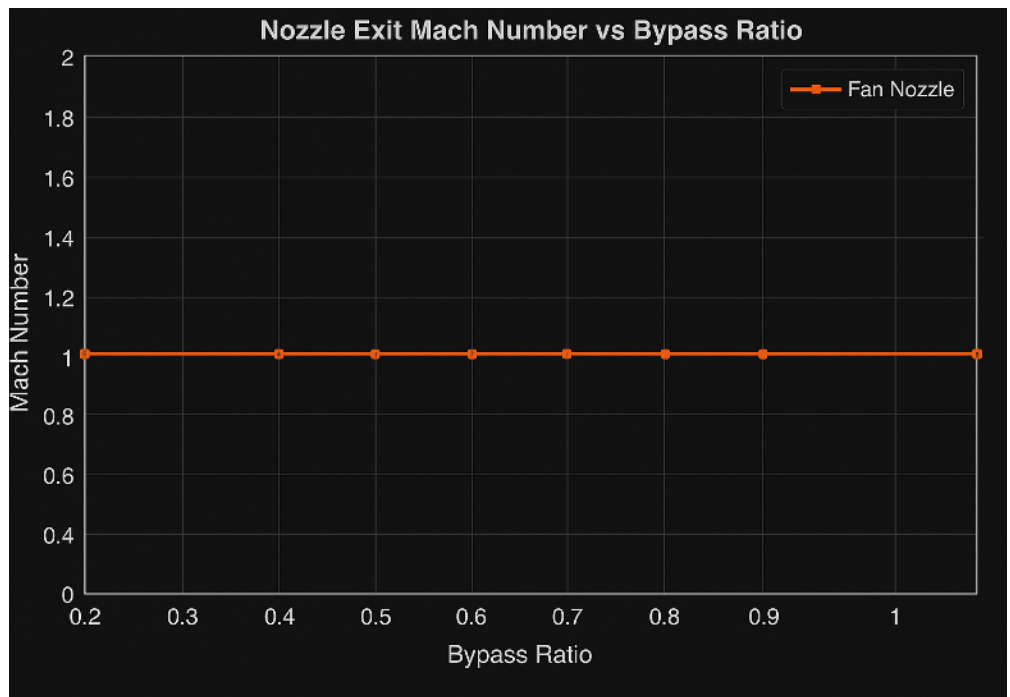

Fig 2.5- Relation between Froude Efficiency and Bypass ratio of LBPT engine in Ideal Conditions

Fig 2.6- Relation between Total Entropy Generation and Bypass ratio of LBPT engine in Ideal Conditions

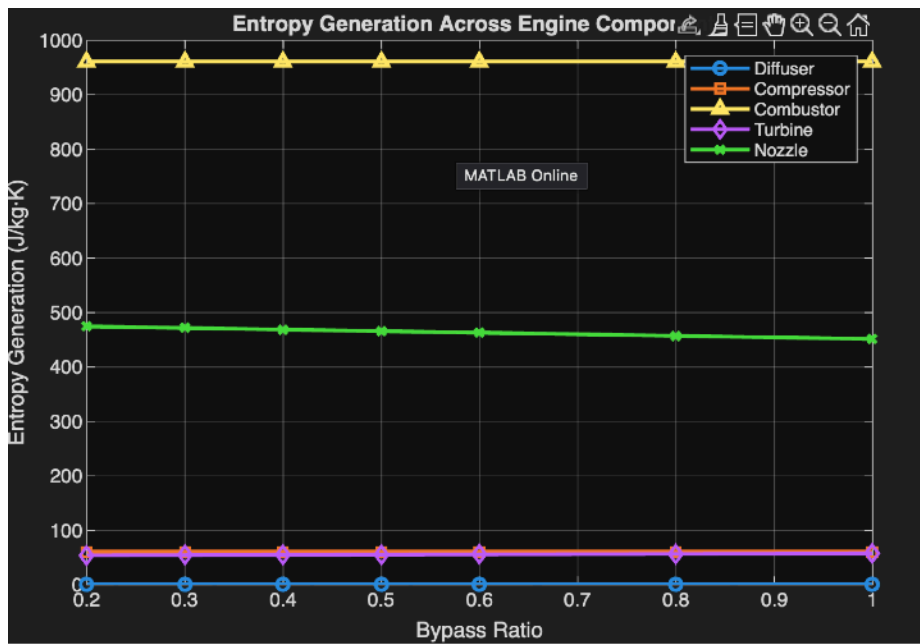
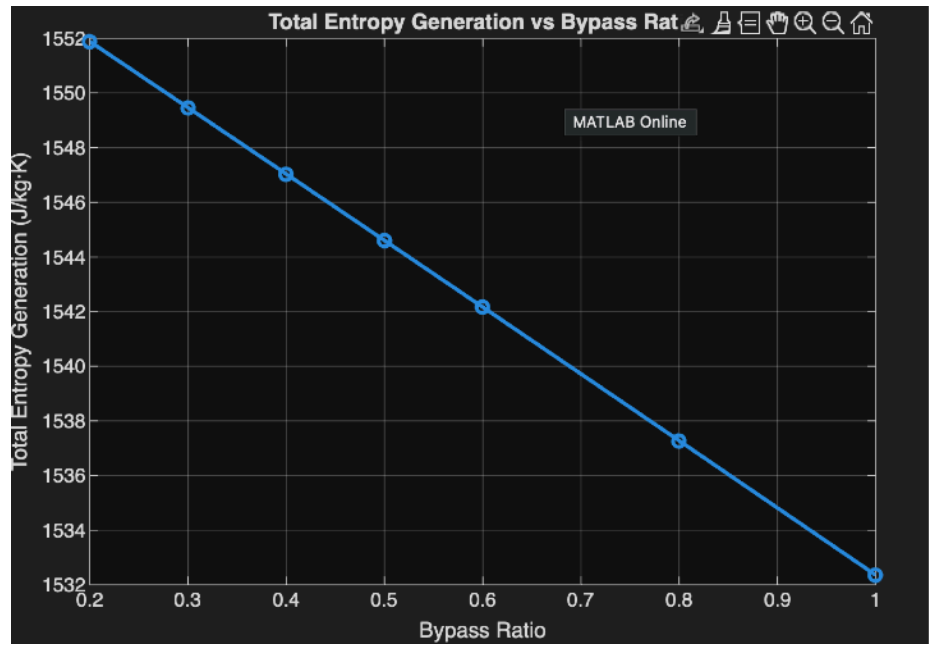
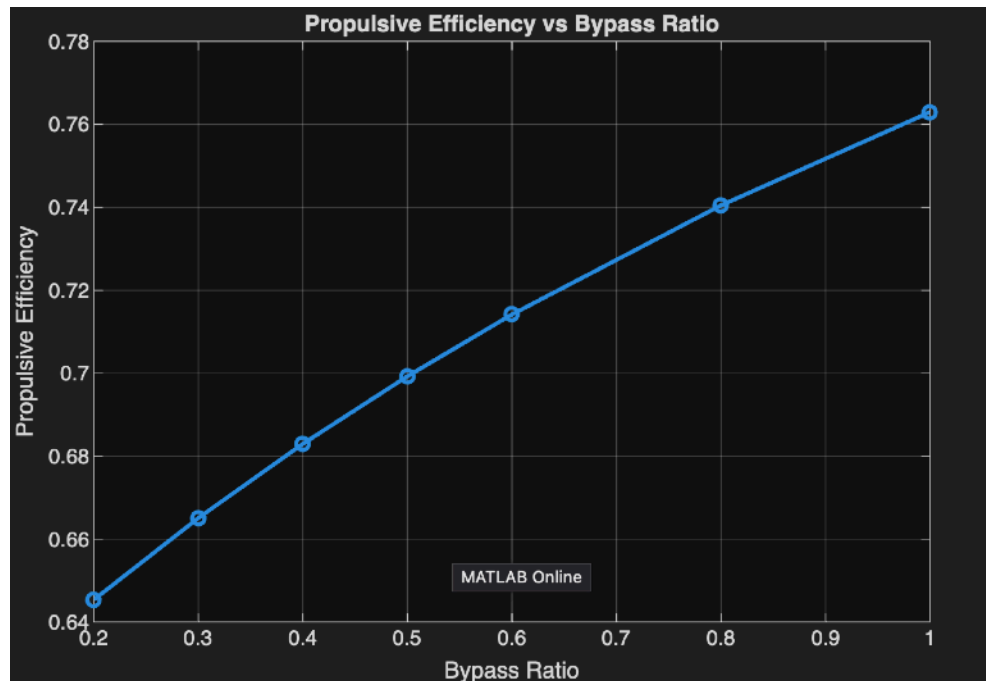

Fig 2.7- Relation between Entropy Generation by parts and Bypass ratio of LBPT engine in Ideal Conditions

Fig 2.8- Relation between Propulsive efficiency and Bypass ratio of LBPT engine in Ideal Conditions



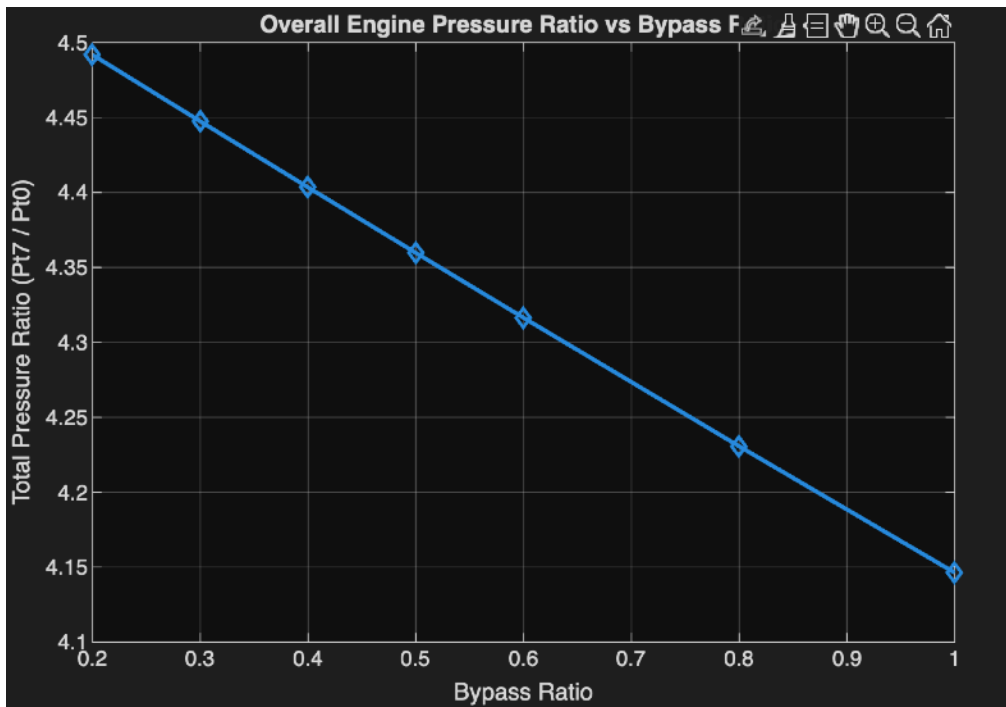

Fig 2.9- Relation between Total Pressure ratio and Bypass ratio of LBPT engine in Ideal Conditions

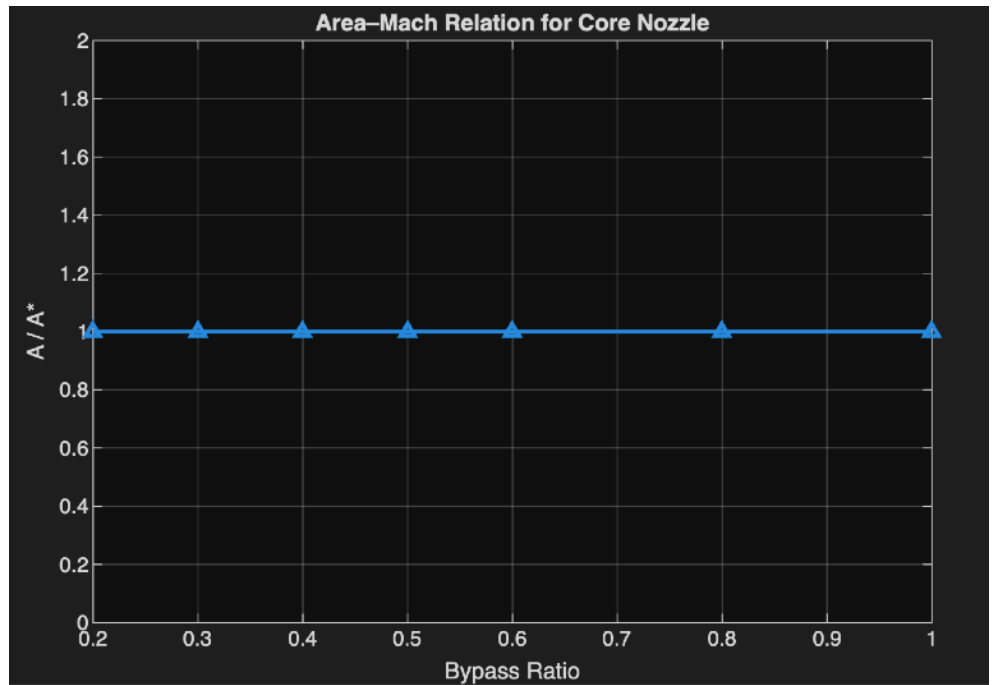

Fig 2.10- Area Mach Relation for core nozzle

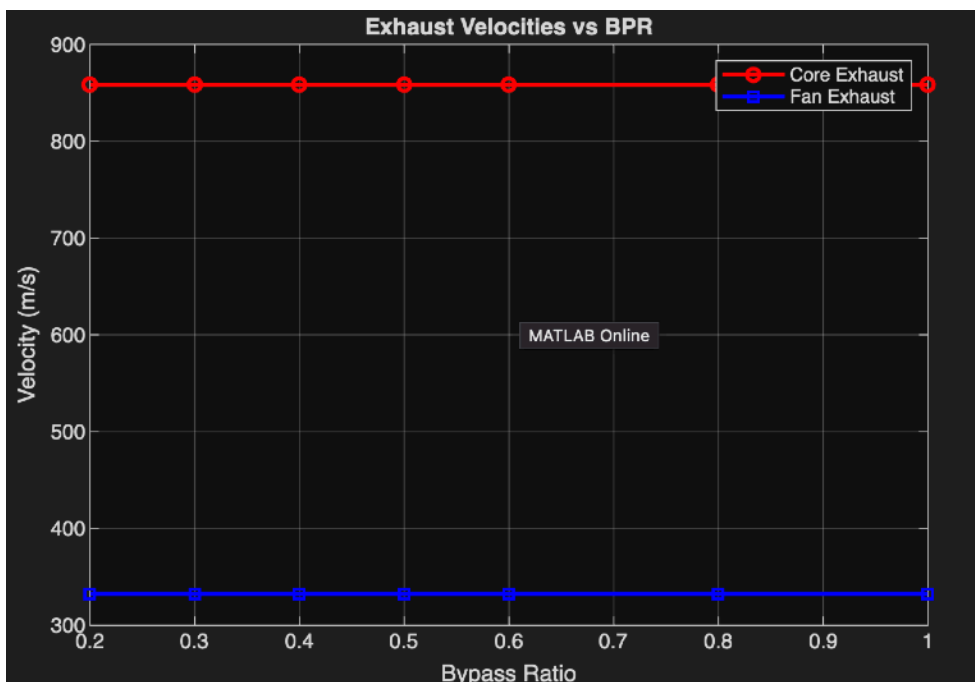

Fig 2.11- Relation between Exhaust velocity and Bypass ratio in LBPT engine under Ideal conditions

Fig 2.4- Relation between Thrust-Specific Fuel Consumption(Kg/N/hr) and Bypass ratio of LBPT engine in Ideal Conditions

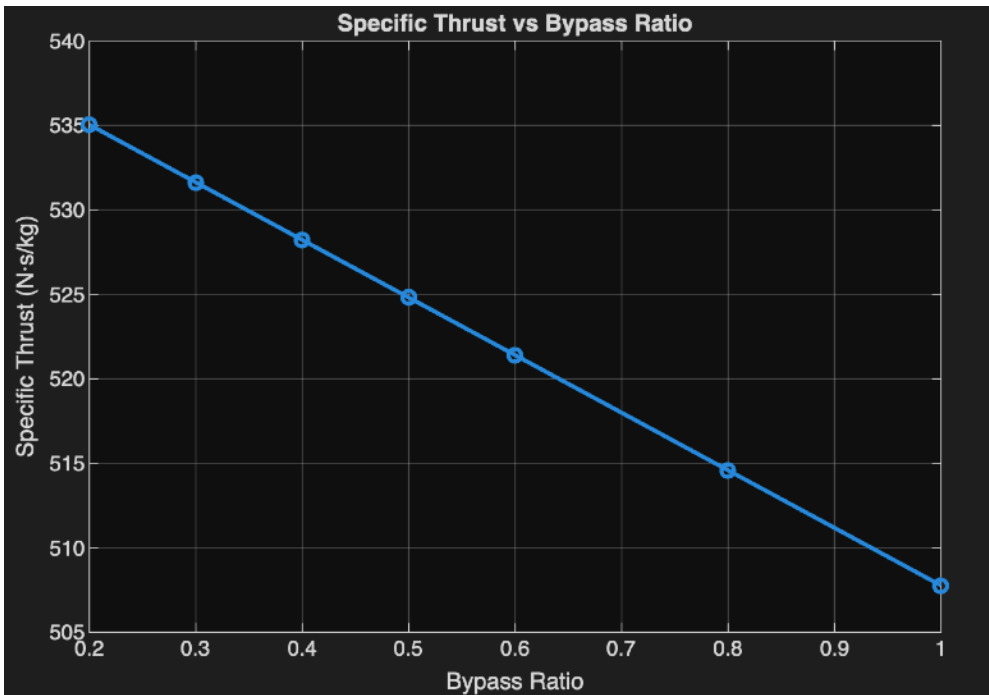
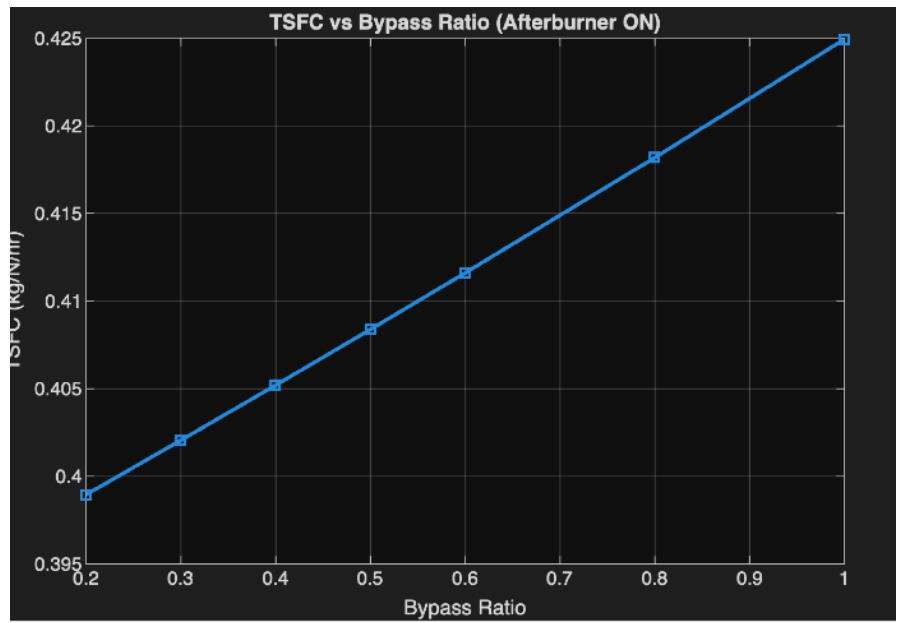

Fig 2.4- Relation between Specific Thrust and Bypass ratio of LBPT engine in Ideal Conditions