

# MODERN COMPREHENSIVE METHODS OF REAGENT-FREE LIQUID TREATMENT

*Alexander Sokolov*

*Saint Petersburg State University of Architecture and Civil Engineering*

*Smart Limited Liability Company*

*Saint Petersburg*

## **Abstract:**

The application and creation of a comprehensive system of contactless electromagnetic resonance monitoring of the state of liquids can be regarded as an integrative manifestation of the ideal final result in accordance with the criteria of the Theory of Inventive Problem Solving (TRIZ).

Precisely integrative, because the technology is a comprehensive and highly efficient compilation of a whole range of systemic technologies, including, of course, nanoscale technological solutions in several borderline technological fields.

The quality of technological solutions and liquids, as a subject of purposeful innovation activity, has acquired particular importance in our time owing to many deep-seated global processes, including global warming, the use of biological-chemical additives in base technological solutions, and the use of genetically modified materials and compounds, as well as the presence of many other risk factors, such as the constant increase in the volume of chemical fertilizer use.

## **Keywords:**

**Comprehensive methods; Reagent-free treatment methods; Subsequent contactless monitoring; Parallel monitoring; Quality of technological solutions and liquids; Base technological solutions; Vortex generator; Borderline technological fields; Presence of many risk factors; Genetically modified materials; Liquid treatment systems; Induction activity of fields; Systematic quality-level control; Electromagnetic resonance spectroscopy;**

**Contents:**

**Introduction: p. 2;**

**Proposed method of comprehensive, fully remote monitoring of the state parameters of a material liquid object: p. 4;**

**Treatment of liquids and solutions containing organic materials in combination with heavy metals: p. 7;**

**Formation of vortex cutters for surface cleaning: p. 9;**

**List of references and patent license materials used: p. 12;**

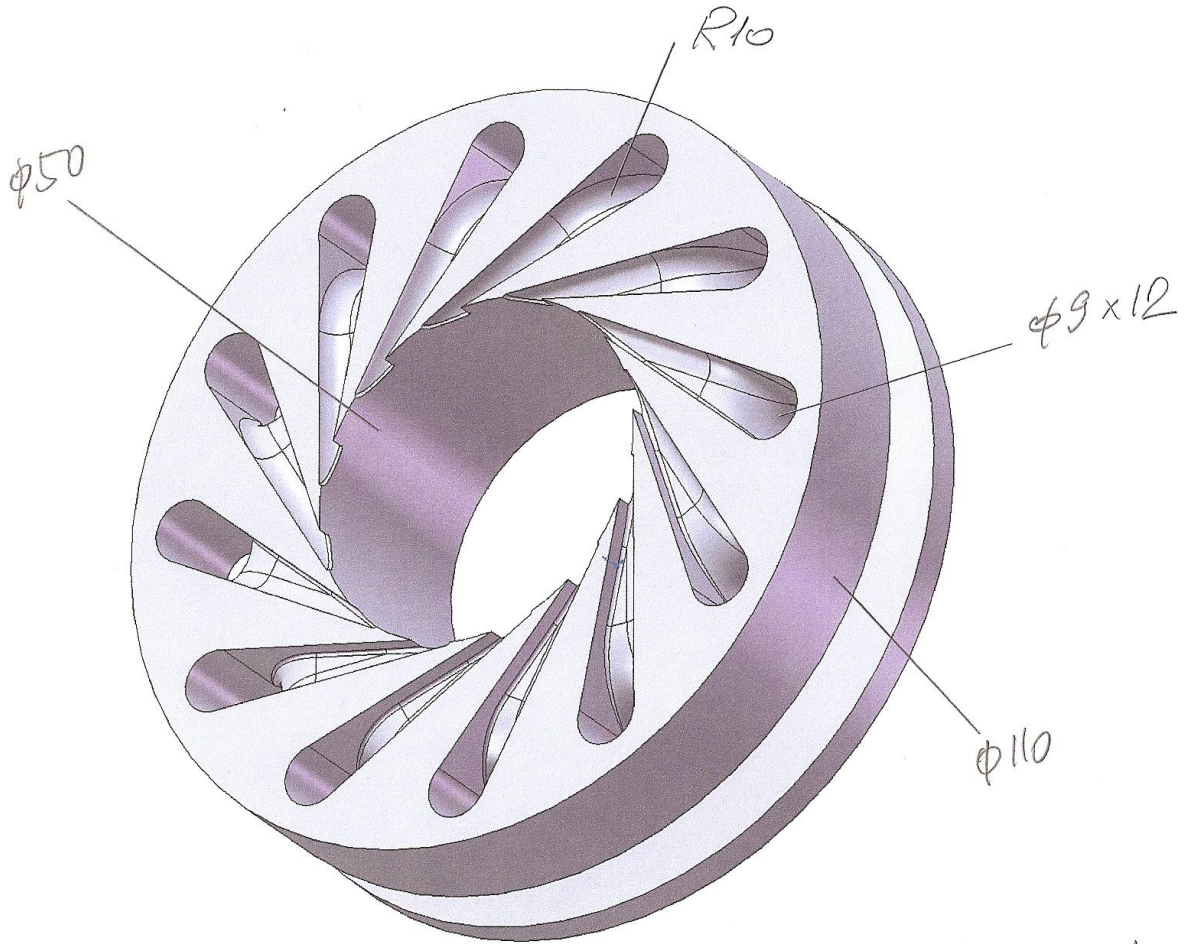

**Figure 1.** One of the basic elements for forming a system for treating liquids and solutions — the vortex generator

The quality of technological solutions and liquids, as a subject of purposeful innovation activity, has acquired particular importance in our time owing to many deep-seated global processes, including global warming, the use of biological-chemical additives in base technological solutions, the use of genetically modified materials and compounds, and the presence of many other risk factors, such as the constant increase in the volume of chemical fertilizer use.

As process-engineering and environmental specialists emphasize, in order to systematically control, even to some degree, the quality level of any technological solutions, emulsions, and blends — especially products of composite or

multicomponent processes — traditional control methods, and contactless monitoring even more so, are no longer sufficient.

To carry out quality control of liquids at a level that meets the demands of the times, a system of sensors operating on the principles of magnetic resonance has been invented.

It is worth dwelling in more detail on the essence of this method:

The method involves the creation of an alternating electromagnetic field in the space in which the sample under study is located. This field is the intermediary, or connecting element, between the resonant circuit and the test sample.

On the one hand, the resonant circuit is the emitter (radiator) of this field, and on the other hand the acceptor (sensing element) of those changes in the electromagnetic field that are introduced by the test sample.

Even in the absence of a test sample, the alternating electromagnetic field created by the sensor's solenoid is the combined sum of two electromagnetic fields that change in antiphase to each other. One field is generated by a change in the magnetic induction of the solenoid of the system's controlling element and results in a vortex electric field (Maxwell-Faraday equation).

The other is generated by a change in the electric field created by the potential difference between the outermost, most widely separated turns of the said solenoid (if the sample is placed inside the solenoid), or by the potential difference between the turn nearest the surface of the element being measured and the measured element itself (if the element is positioned opposite the end face of the solenoid) and results in a vortex magnetic field (Ampère's circuital law with Maxwell's correction).

Under the influence of the said external alternating electromagnetic field, electrical phenomena such as linear and vortex conduction currents, linear and

vortex displacement currents (caused by dielectric polarization), and also linear and vortex ionic currents (the ordered motion of ions) can be induced in the test sample in parallel and simultaneously, depending on its nature.

In accordance with the principle of the induction activity of fields, these electrical phenomena introduce distortions into the said external alternating electromagnetic field. These distortions are perceived by the solenoid of the controlling element — the resonant sensor.

The resonant circuit of the said controlling element, which includes this solenoid, under the influence of the said distortions changes its behavior in the same way as if additional elements such as a capacitor, an inductor, and a resistor had been added to it.

The combination of these additional capacitive, inductive, and active (resistive) impedances constitutes the additional impedance introduced into the system by the test sample; it is this additional impedance that the contactless controlling element — the resonant sensor — measures.

Changes in the parameters of the resonant circuit are reflected in changes in its amplitude-frequency characteristic; namely, during this change, the resonant frequency and amplitude of the said resonant circuit, which is part of the system's controlling element, change. By studying the magnitude and nature of these changes, one can judge the impedance of the sample under study.

The device for magnetic-resonance quality control of technological solutions, including water or aqueous solutions, is a section of pipeline on the outer surface of which a ring sensor is installed, connected to a power source and to a system for signal control, amplification, and identification;

The system optionally includes a transmitting device for sending the amplified and identified signal to an aerial-survey operator's console, or to the processor of an unmanned aerial vehicle, or even to a mobile phone;

The system is calibrated to a reference sample of water or any other liquid, taking into account all local conditions;

The system's sensor registers any change in the state of the water or any other liquid; the signal is identified and transmitted to the aerial-survey operator's console, a computer monitor, or a mobile phone;

The frequency of control tests can be adjusted within the range from one test every 0.1 seconds to one test per minute;

Among the main parameters of the sensor for resonance quality control of water or other above-mentioned types of technological liquids are accuracy and sensitivity; the main parameter — sensitivity — is the ability to distinguish, register, and identify a difference equivalent to 0.000 001 grams per liter;

Performing similar control operations based on existing technology requires specially trained, qualified personnel whose cost per working hour exceeds 35 US dollars;

The personnel cannot perform more than one test per day, and between tests the state of the water or liquid material is not monitored, which leads to emergency situations;

The time from the moment a problem is detected to its elimination is increased because there is no possibility of continuous monitoring of water quality; the

transmission of information is not prompt, which also increases the time needed to resolve emergency situations;

The proposed method of comprehensive, fully remote monitoring of the state parameters of a material liquid object can serve as an equivalent of the ideal final result and includes:

- the formation of a three-dimensional spatial system in which the controlling element encloses the controlled element;
- the alignment of the centers of symmetry of the cross-sections of the controlling and controlled elements of the said three-dimensional spatial system;
- the stabilization of a uniform gap between the outer surface of the controlled element and the controlling element of the said three-dimensional spatial system;
- the formation, around and inside the volume occupied by the controlling element, of an energy-saturated space in the form of an alternating electromagnetic field with controlled and adjustable field strength;
- the action of the said alternating electromagnetic field on the controlled element and the excitation in it of linear and vortex conduction currents, linear and vortex displacement currents, and linear and vortex ionic currents;
- the identification and comparative analysis of the distortions arising in the said alternating electromagnetic field and their perception by the resonant circuit of the controlling element as additional elements — a capacitor, an inductor, and a resistor;
- the recording of the levels of the distortions that arise and of the changes in the parameters of the said resonant circuit with respect to its amplitude-frequency characteristic, in the form of changes in the resonant frequency and amplitude,

and, on this basis, the estimation of the impedance of the controlled element, which determines the state parameters of the material object;

In addition, the proposed method of remote monitoring of the state parameters of a liquid material object — predominantly in the form of a liquid, or a mixture of liquids, or a mixture of liquids and gases, or in the form of aerosols — includes:

- the formation of a three-dimensional spatial system in which the controlling element encloses the controlled element, placed in a shell that defines and maintains the geometric shape of the controlled element;
- the alignment of the centers of symmetry of the cross-sections of the controlling and controlled elements of the said three-dimensional spatial system;
- the stabilization of a uniform gap between the outer surface of the controlled element placed in the said shell and the inner surface of the controlling element of the said three-dimensional spatial system;
- the formation, around and inside the volume occupied by the controlling element, of an energy-saturated space in the form of an alternating electromagnetic field with controlled and adjustable characteristics;
- the excitation and concentration, within the volume of the controlled element placed in the said shell and coupled to the resonant circuit of the controlling element by means of the alternating electromagnetic field, of linear and vortex conduction currents, linear and vortex displacement currents, and linear and vortex ionic currents;
- the identification and comparative analysis of the distortions arising in the said alternating electromagnetic field and ensuring their perception by the resonant circuit of the controlling element as additional elements — a capacitor, an inductor, and a resistor;

- the recording of the levels of the distortions that arise and of the changes in the parameters of the said resonant circuit with respect to its amplitude-frequency characteristic, in the form of changes in the resonant frequency and amplitude, and on this basis, the estimation of the impedance of the controlled element, which determines the state parameters of the material object;
- a sequential change, equal in number to the number of constituent components in the material object placed in the said shell, of the values of the characteristics of the energy-saturated space in the form of the alternating electromagnetic field formed around and inside the volume occupied by the controlling element;
- the identification and comparative analysis of the distortions arising in the said alternating electromagnetic field and ensuring their perception by the resonant circuit of the controlling element as additional elements — a capacitor, an inductor, and a resistor;
- the sequential recording of the levels of the distortions that arise and of the changes in the parameters of the said resonant circuit with respect to its amplitude-frequency characteristic, in the form of changes in the resonant frequency and amplitude, and, on this basis, the estimation of the impedance of the controlled element, which determines the state parameters of the constituent components of the controlled material object;

The energy-saturated space in the proposed technical solution is an alternating electromagnetic field characterized by frequency and field strength;

Controlling and adjusting the parameters of the alternating electromagnetic field makes it possible to ensure the required accuracy and flexibility of measurements and of the monitoring of the parameters of material objects in their various variations;

Since, for the proposed method, there is no difference in the perception of hard or soft materials, liquid or solid materials, or a mixture of liquid and gaseous materials, the adaptation and adjustment of the method to various conditions can be done on the basis of a minimum of technological factors;

If the problem of monitoring liquid materials and products and technological solutions, mixtures, and emulsions is considered from a practical point of view, then, for the application of the latest methods of remote monitoring or contactless quality control, it can be assumed that the accuracy of monitoring and the sensitivity of the sensors depend entirely on the number of components in the mixture of liquids.

In this connection, the transition of all industrial sectors, even a partial one, to systematic multicomponent technological containers or packaging will make it possible to minimize the number of components simultaneously subjected to monitoring or control, which will significantly increase the accuracy and quality of monitoring and open the way to an innovative measurement technology without direct contact with the measured liquid and from considerable distances, as is the case with aerial photography or equivalent unmanned methods of real-time monitoring.

It is necessary to note some features of the application of the said treatment methods for various situations and technological transitions.

1. Treatment of liquids and solutions containing organic materials in combination with heavy metals

To separate the liquid into a fraction with a high concentration of organic substances and a liquid containing heavy-metal ions, a combined treatment is used, in which the properties and parameters of the foam formed change as the pressure of the compressed air changes;

The liquid with a high concentration of organic substances is separated together with the foam, and after the foam is removed, a liquid remains that contains predominantly heavy-metal ions.

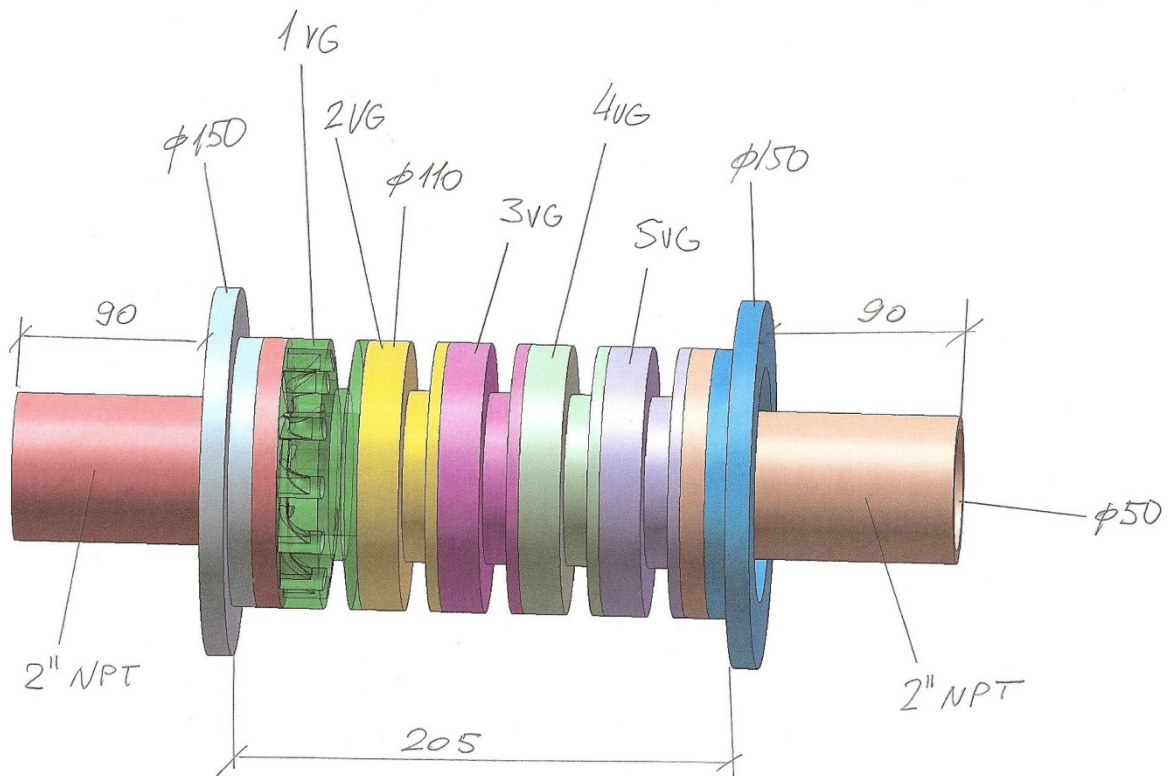

**Figure 2.** System for the online formation of a vortex tube within a pipeline, consisting of 5 vortex generators in series

2. Treatment of liquids with an acidic background containing heavy metals in combination with organic acids

As a rule, such liquids contain complex contaminants (TSS , TDS , BOD , COD), and to extract the heavy metals it is first necessary to separate the contaminant fractions.

To separate the liquid into a fraction with a high concentration of organic substances and a liquid containing heavy-metal ions, a combined treatment is used, in which, upon a change in the pressure of the compressed air, the properties and parameters of the foam formed change;

The liquid with a high concentration of organic substances is separated together with the foam, and after the foam is removed, a liquid remains that contains predominantly heavy-metal ions.

In addition, active uniform treatment with air leads to the primary formation of oxides, which simplifies the process of further treatment of the water or aqueous solution.

### 3. Treatment of liquids with an alkaline background containing heavy metals in combination with heavy-metal salts

As a rule, such liquids contain complex contaminants (TSS , TDS , BOD , COD), and to extract the heavy metals it is first necessary to separate the contaminant fractions.

To separate the liquid into a fraction with a high concentration of organic substances and a liquid containing heavy-metal ions, a combined treatment is used, in which the properties and parameters of the foam formed change as the pressure of the compressed air changes;

The liquid with a high concentration of organic substances is separated together with the foam, and after the foam is removed, a liquid remains that contains predominantly heavy-metal ions.

### 4. Formation of vortex cutters for surface cleaning

The formation of a vortex tube makes it possible to create active cavitation on the surface being cleaned and washed, which increases the cleaning and washing efficiency by a factor of 3–5 and reduces the consumption of water required for these technological operations by a factor of 1.8–2.5.

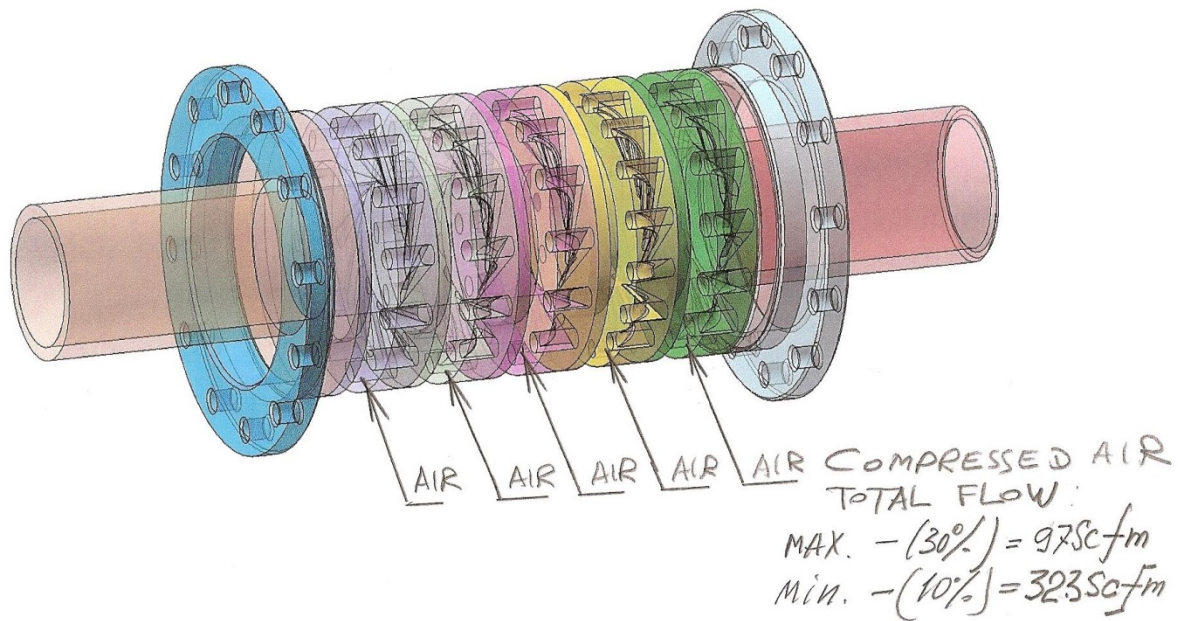

**Figure 3.** Connection diagram of a system for creating, within a pipe, the conditions for forming a vortex flow — a vortex tube

#### 5. Tanks for washing large parts

In this case, foam-forming devices (foam generators) are used to create a regime of uniform excitation and activation with minimal gas-bubble sizes and a rise in the liquid level in the tank that occurs during the operation of the foam generators, which makes it possible to reduce the volume of water contaminated during washing by 25–35%.

#### 6. Saturation of liquids with gas

The use of foam generators or their structural equivalents makes it possible to increase the efficiency and reduce the cost of processes for saturating various liquids with various gases.

Moreover, foam-generator technology makes it possible to have full real-time control over the geometry of the compressed-gas bubbles during the saturation process.

## 7. Cooling of rolled stock in metallurgy

Water or an aqueous solution can be modified by introducing a stream of compressed-gas bubbles (for example, nitrogen) no larger than 25–50 microns in size.

When introduced into the liquid, the gas lowers its temperature, and subsequently, upon contact with the cooled surface and upon the rupture of the air-bubble shells, the gas expands and more substantial cooling occurs.

This makes it possible to reduce the energy consumption for cooling by a factor of 2–3 and to substantially increase the efficiency of the cooling process.

With the same energy consumption, the cooling process can be carried out in parallel with the process of washing or cleaning the cooled surfaces.

## 8. Technologies of classical flotation

Foam-forming devices (foam generators) can be used effectively to produce air bubbles of uniform size.

Moreover, the adjustment of the technological regimes is considerably simplified, since it is carried out solely by adjusting the parameters of the compressed air.

At the same time, energy consumption is significantly reduced and the cleaning quality is improved.

## 9. Technologies of combined flotation with dynamic foaming

Foam generators can be used to create a combined flotation process in which, in the first stage, at high air pressure (6–8 bar), foam is formed, and after its separation, at low pressure (0.5–1.5 bar), treatment is carried out by forming a uniform stream of air bubbles.

10. Technologies of forced separation of liquid and contaminants by introducing small concentrations of detergents into the liquid being cleaned

In many cases, the liquid being cleaned does not contain foaming substances.

In this case, it is advisable to introduce a small amount of detergent into the liquid (no more than 25 milligrams per liter of the liquid being cleaned).

The active foam formed during the operation of the foam generator makes it possible to significantly reduce contaminant concentrations before the foam generator switches to producing air bubbles and correspondingly transitions to the classical flotation regime.

11. Technologies of dynamic mixing of liquids with different properties

When a liquid, instead of air, is fed to the foam generator and the stream emerging from the foam generator is introduced into a volume of another liquid, an efficient, uniform dynamic mixing process takes place that is 5–7 times more effective than mechanical stirring.

12. Water-saving technologies for technological baths

The use of foam generators in various technological baths, and the effect of raising the level of water or any other liquid in the bath, makes it possible to lower the level of water or other technological solution in the bath by 25–30%.

This yields a 10–15% saving in technological solutions, with low energy consumption for preparing the compressed air.

13. Technologies for forming a fine-dispersed mist

Above the surface of the vortex tube formed during the operation of the foam generator, a mist appears consisting of air bubbles in a shell of the liquid in which the foam generator operates.

For fine and precise washing technologies, it is preferable to use mist treatment with a high cavitation effect, which arises upon the rupture of the air-bubble shells.

For the effective formation of mist, an air pressure of 7–8 bar is required, at a flow rate determined on the basis of the volume of the liquid being treated.

#### 14. Treatment of aqueous solutions with a high concentration of contaminants

Carried out for the preliminary treatment of aqueous solutions before electrochemical or any other treatment.

For treatment, the aqueous solution is foamed, and the contaminants are concentrated in the foam.

The more the contaminants are prone to forming foam, the more effective the treatment process.

The contaminants are removed together with the foam.

For the effective formation of foam, an air pressure in the range of 6–8 bar is required (the flow rate is determined on the basis of the volume of the liquid being treated).

#### 15. Treatment of aqueous solutions containing chemical complexes

Carried out for the preliminary treatment of aqueous solutions before electrochemical or any other treatment.

In this case, foaming of the aqueous solution is used, during which the solution together with all impurities is oxidized, and all impurities end up in the foam, since water does not foam;

If the foam is continuously removed, the system reaches a point at which all substances that have foam-forming properties are removed from the solution.

For the effective formation of foam, an air pressure in the range of 6–8 bar is required (the flow rate is determined on the basis of the volume of the liquid being treated).

**List of references and patent-license materials used:**

Appendix 1

**United States Patent Application      20180186656**

**Kind Code                                      A1**

**Drewniak; Marta ; et al.                  July 5, 2018**

---

System and Method for Automated Control, Feed, Delivery Verification, and Inventory Management of Corrosion and Scale Treatment Products for Water Systems

**Abstract**

A system and method of controlling the treatment of water systems comprises multiple feeders for separately feeding treatment products, in the form of concentrated, *non*-hazardous, *liquids* with a single active ingredient, to a water system to treat various issues, such as corrosion and biofilms. A sensor verifies delivery of the treatment product to the water system. A controller controls activation of each feeder to control a feed rate according to programmed functions. The controller receives signals from sensors, which can be used as inputs in calculating feed rates or feeder activation times according to the programmed functions and can alter treatment product feed rates based on real time data regarding water system chemistry or flow rates. The controller can send and

receive data, signals, alerts, alarms or changes in programming to or from remote users, remote computers, or a water system controller.

## Appendix 2

<b>United States Patent Application</b>	<b>20180134554</b>
<b>Kind Code</b>	<b>A1</b>
<b>ALVAREZ, JR.; Daniel ; et al.</b>	<b>May 17, 2018</b>

---

## METHODS AND SYSTEMS FOR PURIFYING HYDROGEN PEROXIDE SOLUTIONS

### Abstract

Compositions, methods, devices, and systems for purifying a source liquid from a replenishment stock solution that includes stabilizing agents, such as metal ions, prior to vaporization. Certain embodiments effect the purification with a solid per-fluoronated ionomer, such as a per-fluoronated ionomer membrane. Advantageously, source *liquids* purified in this manner provide feed stocks for production of ultra-pure gaseous reagents. As well, performance characteristics of membrane-based vaporizers relying on transport processes are improved.

## Appendix 3

<b>United States Patent Application</b>	<b>20180128656</b>
<b>Kind Code</b>	<b>A1</b>
<b>Hay; Stephane ; et al.</b>	<b>May 10, 2018</b>

## SENSOR

### **Abstract**

A sensor for operating in an environment subjected to corrosive gases or *liquids* under pressure, including a housing inside which are installed: a sensing portion, at least one wire electrically connected to the sensing portion, and a seal for sealing the connection between the sensing portion and the at least one wire, with at least one through-hole receiving a portion of the at least one wire. The sensor further including a compressor installed inside the housing, movable with respect to the housing and adapted to *contact* the seal in order to compress. The seal is made from a single material that is softer than the material constituting the housing. Upon displacement of the compressor, the seal is deformed until the creation of a compression force exerted by the seal onto the portion of the at least one wire, prevents any passage of corrosive gases or *liquids* between the seal there-between.

Appendix 4

**United States Patent Application      20180119502**

**Kind Code                                      A1**

**Shanks; David L. ; et al.                May 3, 2018**

---

Method of Capturing Vapor Phase Fluids From Fluid Returns In A Tank

### **Abstract**

A gas trap system for releasing gas-phase fluids is provided herein. The gas trap system is designed to reside within a return fluids tank, such as at a drill site. The gas trap system first includes a gas trap. The gas trap is configured to agitate drilling fluids in the return tank, and then to release gases during agitation. *Liquids* are circulated and released through a *liquids* exhaust port while gases are released through a gas exhaust port near the top of the gas trap. The gas trap system is configured to float along vertical guide rods in response to changes in height, weight and viscosity of the drilling fluids in the return tank. A method of capturing gaseous phase fluids from a fluid return is also provided herein. The fluid return is preferably drilling fluids at a drill site.

#### Appendix 5

<b>United States Patent Application</b>	<b>20180070866</b>
<b>Kind Code</b>	<b>A1</b>
<b>Raahemifar; Kaamran ; et al.</b>	<b>March 15, 2018</b>

---

**NON-INVASIVE NANOSENSOR SYSTEM TO DETERMINE ANALYTE CONCENTRATION IN BLOOD AND/OR BODILY FLUIDS.**

#### **Abstract**

The device is an ultra-low power, *non*-invasive in-vivo blood analyte sensor system incorporating multiple sensors including a carbon base and/or carbon base material coated with metallic nanoparticles and/or metallic nanoparticle nanoprobe, as a modified Clark electrode sensor system, that detects hydrogen peroxide concentrations, pH, and/or glucose concentrations (and other analytes) in bodily secretions (e.g. tears, saliva, sweat). The device consists of multiple chemoreceptive sensors, a microprocessor, a signal amplifier, signal filtering,

error correction algorithms, analog-to-digital converter and wireless electromagnetic data transmitter to a remote device for further processing and/or data storage (e.g. on a server, on a cloud-based storage system, etc) and/or visual representation via software. The method involves applying the nanoprobe sensor array to skin tissue and the resulting electrical impulses correlate with glucose concentration within *liquids* such as tears, saliva, blood, etc. The collected data is then represented visually on a computer (handheld, smart-phone, desktop, laptop, etc) via software. The device is powered by ambient electromagnetic radiation, thermoelectric and/or solar power and/or rechargeable battery. The device is placed against the skin or immersed in a sample for sensor measurement. Single and continuous data collection is possible. The device can be reused repeatedly, re-sterilized and it is a high accuracy, low-cost option for multiple use glucose concentration measurements. The device can monitor blood glucose for Type I and Type II diabetics and it is suitable for a wide range of applications including gases, *liquids* and solids, biological, organic and inorganic chemical analysis.

## Appendix 6

<b>United States Patent Application</b>	<b>20170328928</b>
<b>Kind Code</b>	<b>A1</b>
<b>Brennen; Reid A. ; et al.</b>	<b>November 16, 2017</b>

---

SYSTEMS AND METHODS FOR TRANSFERRING LIQUIDS

## Abstract

One or more *liquids* are transferred from a source array to one or more remotely positioned destination sites such as chambers by utilizing one or more movable

transfer elements, such as *contact* pins or capillaries. The source array may include a predetermined organization of addresses at which materials are positioned. One or more materials may be selected for transfer. Based on the selection, one or more addresses may be accessed by the transfer element(s). The addresses may correspond to spots on a surface of the source array. Each spot may be a feature containing one or more (bio)chemical compounds. At the chamber(s), the material(s) may be processed, such by reaction with one or more reagents. The reaction(s) may entail synthesis of one or more desired products. Alternatively, reaction(s) may be performed at the source array, and the product(s) then transferred to the chamber(s).

## Appendix 7

<b>United States Patent Application</b>	<b>20170269108</b>
<b>Kind Code</b>	<b>A1</b>
<b>Letourneau; Nicolas ; et al.</b>	<b>September 21, 2017</b>

---

## METHODS AND APPARATUS FOR DETECTING COMPOUNDS IN LIQUIDS

### **Abstract**

Described herein are apparatus and methods for detecting substances of abuse or other analytes in *liquids*. For example, the apparatus and methods described herein can be used for real-time detection of analytes, such as substances of abuse. The methods comprise providing a detection area comprising a chromatographic membrane capable of receiving the liquid and allowing for migration of the liquid, the chromatographic membrane comprising an anti-analyte antibody-particle conjugate, an analyte-conjugate protein at a test line; exposing at least the

first location of the apparatus to the liquid; and determining whether an interaction between the analyte-conjugate protein and the liquid occurs to detect the presence of the analyte. The chromatographic membrane may further comprise an anti-species antibody at a control line. Specific buffers are disclosed, and these buffers may be used in the preparation of the apparatus to overcome challenges associated with miniaturization and challenges associated with exposure to beverages.