

# Solar One – A Proposal for The First Crewed Interstellar Spacecraft

Alberto Caballero<sup>1</sup>

## Abstract

In this paper it is presented the concept and design of a beam-powered propulsion system that could become the first manned interstellar spaceship. Light-sail spacecrafts such as the so-called StarChips from the Starshot project have already been designed, but this type of spaceship might not be the best option to explore exoplanets in detail. Solar one would be a manned spaceship that would integrate three existing or near-term technologies, namely: the US Navy CFR fusion reactor, a larger version of NASA's Sunjammer light sail, and a continuous-wave version of the Teramobile laser system. With a mile-long light sail, Solar One could accelerate at almost 1 g and reach 30% the speed of light, arriving at the Alpha Centauri system in around 15 years.

## 1. INTRODUCTION

Several light-sail spacecrafts have already been tested. Some examples are LightSail 1 and LightSail 2, from the Planetary Society. However, these light-sails are propelled by sun light, and the solar radiation pressure is very small (just 6.7 Newtons per gigawatt, which equals to 9 Newtons/km<sup>2</sup> or 1,400 watts/m<sup>2</sup> at 1 AU). Lasers can provide radiation pressures much higher than the Sun.

Previous experiments with directed-energy weapons have proved successful. The Boeing YAL-1, a spacecraft equipped with a Kilowatt-laser, was able to deliver a power density over 100 watts/cm<sup>2</sup> at a distance of 1 km (US Air Power, 2008).

In 2016, scientists announced the first design for a beam-powered spacecraft that could reach speeds of 0.2c. The project, called StarShot, entailed the idea of sending 1,000 nanocrafts with light sails attached that would be powered by a 100 GW laser array. As of today, the concept is still considered to be the best option for unmanned interstellar travel. Potentially habitable exoplanets such as Proxima b could be reached in only 20 years.

However, the idea is to send the Starshot nanocrafts 1 AU away from Proxima b. This

distance would be enough to photograph the exoplanet, but perhaps not sufficient to notice the presence of a possible intelligent civilization less advanced than humanity. For this reason, and to better study the exoplanet, a manned interstellar spaceship becomes necessary.

The proposal more similar to Solar One was presented by Robert Forward in 1984. Forward proposed a 64-ton payload sail surrounded by a 644-ton decelerator sail and launched by a 7.2-Terawatt laser system to reach 21% the speed of light. As the spacecraft approaches Alpha Centauri, another 26-TW laser is pointed towards a 1000-km Fresnel lens that focuses the light into the sail of the spaceship.

## 2. CONCEPT

Solar One is a design for a manned spaceship that would be powered by beamed and photon propulsion. The name 'Solar One' has been chosen to better represent our civilization: the term 'Solar' refers to the solar system and the term 'One' refers to the first design of a possible fleet of future spaceships. Three are the technologies that would be used: the US Navy CFR nuclear fusion reactor, a slightly larger version of the NASA's Sunjammer

---

<sup>1</sup> Coordinator of the Habitable Exoplanet Hunting Project.

light sail, and a Terawatt-mobile laser called Teramobile.

Firstly, the US Navy CFR (Compact Fusion Reactor) is a mobile unit that can provide one Terawatt of power (Forbes, 2019). The weight of similar CFR units has been estimated to be around 200 tons, but Solar One would need 150 Terawatt-reactors. To minimize weight, the use of a Petawatt reactor would be ideal. The units would probably have to be built in orbit due to their size.

Solar One would also carry 25 Terawatt reactors on board to power the laser system needed for deceleration. The size of each of them would have to be reduced to around 2 tons per unit.

Antimatter would be a better source of energy for the laser. Only 10 milligrams of antimatter could yield power densities in the Terawatt order. To produce the antimatter needed, a rocket such as the VARIES Mk 1 could generate Schwinger antiparticle pairs directly from the vacuum (Next Big Future, 2012).

Secondly, the Sunjammer light sail is a proposed NASA sail with a size of 38 x 38 m (1,444 m<sup>2</sup>) (NASA, 2017). Solar One would need a 1.6 km by 1.6 km light-sail.

Finally, Teramobile is a 10-ton portable 5-Terawatt laser currently funded by the French National Research Agency (Wille, 2002). Solar One would need 30 of these Terawatt lasers to achieve 57 MW/m<sup>2</sup>, although a Petawatt laser would be ideal. It is important to bear in mind that current high-energy lasers are usually designed to emit short pulses. A continuous-wave laser would be necessary for Solar One. The system would probably have to be built in orbit due to its size.

Solar One would also have a 25-TW laser system at the front of the cockpit in order to decelerate at destination.

If a 500-mm laser is placed at 586 m from the light sail, and with a divergence of

around 177<sup>o</sup>, an irradiance of 57 MW/m<sup>2</sup> is theoretically achievable.

#### Irradiance Calculator

Beam diameter at aperture:	500 mm
Divergence:	3100 mrad
Distance to audience:	586 m
Laser power:	1500000 mW
Diameter at audience:	1817100.0 mm
Minimum diameter (> 7mm):	1817100.0 mm
Beam area:	2593268818623.4 mm <sup>2</sup>
Irradiance:	5784205.6 mW/cm <sup>2</sup>

Figure 1 – Power density  
Source: Kvant Lasers

Due to the square inverse law, as the spacecraft moves away from the laser, the power density reduces. To maintain the same power density all the time, it would be necessary to incorporate in the laser system an automatic parabolic mirror that would gradually increase its diameter in order to reduce the divergence of the beam (from 3,100 mrad at 586 meters to  $25 \times 10^{-11}$  mrad at 0.76 light years. To avoid the loss of the reflected light, a secondary parabolic mirror could be placed in the centre of the system.

#### Irradiance Calculator

Beam diameter at aperture:	500 mm
Divergence:	0.00000 mrad
Distance to audience:	720000 m
Laser power:	1500000 mW
Diameter at audience:	1800500.0 mm
Minimum diameter (> 7mm):	1800500.0 mm
Beam area:	2546103962451.4 mm <sup>2</sup>
Irradiance:	5891354.1 mW/cm <sup>2</sup>

Figure 2 – Power density  
Source: Kvant Lasers

The idea behind Solar One is to combine the three projects. A 4-crew spaceship with a total mass of around 100 tons (50 tons from the reactors, 50 tons from the laser system, and 10 tons from the light sail, structure, equipment and crew) could be powered by a 1,600 meters-long light sail and achieve the speed of 0.3c with a constant

acceleration and deceleration during approximately the first 100 days of the trip.<sup>2</sup>

$$F^* = 2 (P \times A) / c$$

$$F = 2 (57,000,000 \times 2,560,000) / 300,000,000$$

$$F = 972,800 \text{ newtons}$$

F\* = force (newtons)

P\* = power (watts / m<sup>2</sup>)

A\* = surface area of light sail (m<sup>2</sup>)

c\* = speed of light

The acceleration obtained would around 1 g:

$$a = F/M$$

$$a = 972,800 / 100,000$$

$$a = 9.7 \text{ m/s}^2 \approx 1 \text{ g}$$

a\* = acceleration (m/s<sup>2</sup>)

M = mass (kg)

And it would take around 100 days to reach 0.3 c:

$$t = v / a$$

$$t = 89,994,000^* / 9.7$$

$$t = 9,277,731 \text{ sec} = 107 \text{ days}$$

$$89 \text{ million m/s}^* = 0.3 \text{ c}$$

For the deceleration, considering that photons have a thrust to power ratio of  $3.34 \times 10^{-9}$  newtons per watt, the laser system would provide the following opposite force:

$$F = 25,6 \times 10^{12} \text{ watts} \times 3.34 \times 10^{-9} = 85,504 \text{ N}$$

The acceleration obtained during deceleration would around 0.1 g:

$$a = F/M$$

$$a = 85,504 / 100,000$$

$$a = 0.85 \text{ m/s}^2 \approx 0.1 \text{ g}$$

And it would take around 3.3 years to stop the spacecraft:

$$t = v / a$$

$$t = 89,994,000^* / 0.85$$

$$t = 105,875,294 \text{ sec} = 3.3 \text{ years}$$

At the speed of 0.3 c, the crew would arrive to the Alpha Centauri system in slightly more than 15 years. All the necessary measures would be taken in order to enable the crew to withstand the lack of gravity during such a long trip.

$$\text{Average speed} = 0.23^* \cdot 0.15^* + 0.77^* \cdot 0.3^* = 0.2655 \text{ c}$$

0.23\* = approx. % trip time during acceleration and deceleration

0.15\* = average speed during acceleration and deceleration

0.77\* = approx. % trip time with constant speed

0.3\* = cruise speed

$$\text{Duration of the trip to Alpha Cen} = \text{Distance} / \text{Average speed} = 4.37 / 0.2655 \approx 16 \text{ years}$$

### 3. DESIGN

The spaceship would be composed of the following main elements: a laser system, a light sail, a nuclear micro-reactor, a descend module and a cockpit protected from space

---

<sup>2</sup> A 4-crew spacecraft is expected to have a mass of 10 tons (Manned Spacecraft Design Principles, Pasquale M Sforza).

radiation. An extra amount of light sail would be ideal in case of damage caused by micro-meteorites. To reduce damage and drag, the light sail would be rolled when the spaceship is neither accelerating nor decelerating, that is, 80% of the time.

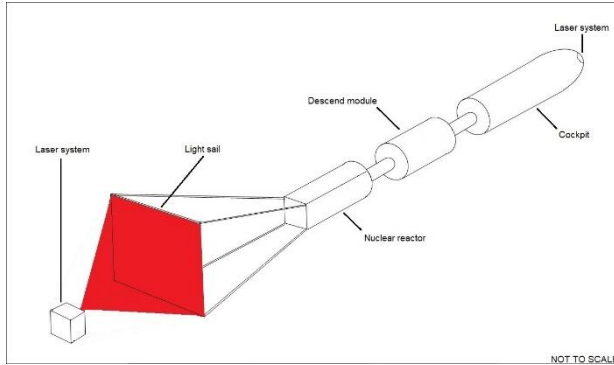

Figure 3 – Solar One

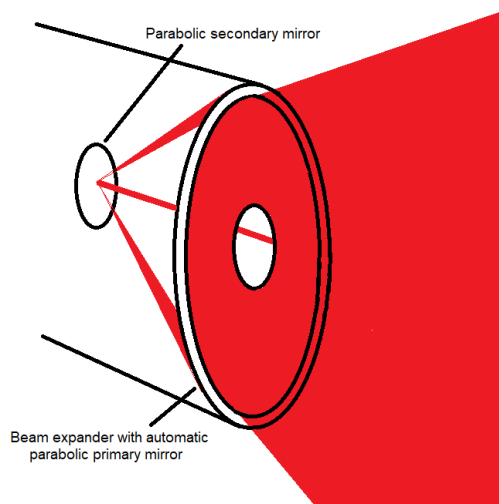

Figure 4 – Acceleration laser

Once the destination is reached, the crew could orbit the exoplanet, take images and send a robot to the surface. If the air turns out to be breathable, the crew could choose to land in order to personally explore the exoplanet.

#### 4. CHALLENGES

Engineers would likely face several challenges while building Solar One. One of them would be to make a laser able to produce a high-energy continuous wave

with the smallest possible energy loss. Forward's proposal (1984) implied an energy loss of 11%. The ideal would be to reduce it to a value closer to zero. Another obstacle would be to reduce the weight of the small nuclear reactors to that of a car. Other challenges would be to protect the reactor module and the light sail from micro-asteroid impacts. Potential nuclear failures include neutron radiation damage and tritium release. The module containing the nuclear micro-reactor would have a protective coating thicker than the rest of the spaceship. The cockpit could also be equipped with an emergency propulsion system such as an ion thruster in case there is a nuclear failure and the crew has to separate from the spaceship. However, this additional system would probably increase the budget and there is also a low chance of survival if the failure occurs outside the solar system.

#### 5. CONCLUSIONS

In this paper it has been analysed the possibility of building a manned interstellar spaceship propelled by an external laser system orbiting the Earth. To decelerate, the spacecraft would use an on-board laser system that would receive the necessary electricity from small nuclear fusion reactors. Small modular reactors such as the US Navy CFR already exist, large light sails such as Sunjammer have already been built, and portable Terawatt-class lasers such as Teramobile have proved successful. Nuclear fusion is the most near-term technology that could be used to power the laser system of Solar One. However, research on antimatter propulsion is advancing at a rapid rate. If scientists are able to produce more antimatter than the energy used to generate it, this would be the best way to power the laser system of Solar One.

## REFERENCES

Bae (2008) 'Photonic Laser Propulsion: Proof-of-Concept Demonstration'. Link: <https://arc.aiaa.org/doi/10.2514/1.32284>

Forbes (2019) 'A Breakthrough In American Energy Dominance? U.S. Navy Patents Compact Fusion Reactor'. Link: <https://www.forbes.com/sites/arielcohen/2019/10/30/a-breakthrough-in-american-energy-dominance-us-navy-patents-compact-fusion-reactor/#77af61c81070>

How Stuff Works. 'How Solar Sail Technology Works.' Link: <https://science.howstuffworks.com/solarsail2.htm>

Idaho National Laboratory (2018) 'Preliminary Assessment of Two Alternative Core Design Concepts for the Special Purpose Reactor'. Link: <https://www.osti.gov/servlets/purl/1413987>

Kvantlasers (2020) 'Laser Calculator'. Link: <https://www.kvantlasers.sk/pages/laser-calculator>

Los Alamos National Laboratory (2019) 'Megapower'. Link: <https://www.lanl.gov/discover/publications/1663/2019-february/assets/docs/1663-33-Megapower.pdf>

NASA (2017) 'Solar Sail Demonstrator ('Sunjammer')'. Link: [https://www.nasa.gov/mission\\_pages/tdm/solarsail/index.html](https://www.nasa.gov/mission_pages/tdm/solarsail/index.html)

Nextbigfuture (2018) 'Russia claims 100 times smaller nuclear reactor than submarine reactors but with more power.' Link: [www.nextbigfuture.com/2018/03/russia-claims-100-times-smaller-nuclear-reactor-than-submarine-reactors-but-with-more-power.html](http://www.nextbigfuture.com/2018/03/russia-claims-100-times-smaller-nuclear-reactor-than-submarine-reactors-but-with-more-power.html)

Next Big Future (2012) 'Vacuum to Antimatter-Rocket Interstellar Explorer System (VARIES): A Proposed Program for an Interstellar Rendezvous and Return

Architecture'. Link: <https://www.nextbigfuture.com/2012/07/vacuum-to-antimatter-rocket.html>

Pasquale M Sforza (2016) 'Manned Spacecraft Design Principles.'

Rene Heller (2016) 'Deceleration of high-velocity interstellar photon sails into bound orbits at

$\alpha$  centauri.' Link: <https://arxiv.org/pdf/1701.08803v1.pdf>

Robert Forward (1984) 'Roundtrip Interstellar Travel Using Laser-Pushed Lightsails'. Link: <https://pdfs.semanticscholar.org/25b2/b991317510116fca1e642b3f364338c7983a.pdf>

Space.com (2013) 'World's Largest Solar Sail to Launch in November 2014'. Link: [www.space.com/21556-sunjammer-solar-sail-launch-2014.html](http://www.space.com/21556-sunjammer-solar-sail-launch-2014.html)

The Drive (2001) 'The U.S. Military Wants Tiny Road Mobile Nuclear Reactors That Can Fit In A C-17.' Link: [www.thedrive.com/the-war-zone/26152/the-u-s-military-wants-tiny-road-mobile-nuclear-reactors-that-can-fit-in-a-c-17](http://www.thedrive.com/the-war-zone/26152/the-u-s-military-wants-tiny-road-mobile-nuclear-reactors-that-can-fit-in-a-c-17)

The Guardian (2008) 'Mini nuclear plants to power 20,000 homes'. Link: [www.theguardian.com/environment/2008/nov/09/miniature-nuclear-reactors-los-alamos](http://www.theguardian.com/environment/2008/nov/09/miniature-nuclear-reactors-los-alamos)

University of Alaska-Fairbanks. 'Physics The physics behind solar sails.' Link: [http://ffden-2.phys.uaf.edu/webproj/212\\_spring\\_2015/Robert\\_Miller/physics.html](http://ffden-2.phys.uaf.edu/webproj/212_spring_2015/Robert_Miller/physics.html)

US Air Power (2008) 'High Energy Laser Directed Energy Weapons'. Link: <http://www.usairpower.net/APA-DEW-HEL-Analysis.html>

Wille H. (2002) Teramobile: A mobile femtosecond-terawatt laser and detection system. Link: <http://www.teramobile.org/publications/AP01224.pdf>

Wired (2008) 'What's Inside Darpa's \$21 Million 'Liquid' Laser?' Link: [www.wired.com/2008/12/darpas-21m-for/](http://www.wired.com/2008/12/darpas-21m-for/)

Young Bae (2012) 'Prospective of photon propulsion for interstellar flight'. Link: <https://cyberleninka.org/article/n/314734>